



# RESEARCH

2009-03

Warning Efficacy of Active Versus Passive Warnings for Unsignalized Intersection and Mid-Block Pedestrian Crosswalks



Take the



steps...

Research...Knowledge...Innovative Solutions!

Transportation Research

## Technical Report Documentation Page

1. Report No. MN/RC 2009-03	2.	3. Recipients Accession No.	
4. Title and Subtitle Warning Efficacy of Active Versus Passive Warnings for Unsignalized Intersection and Mid-Block Pedestrian Crosswalks		5. Report Date January 2009	
		6.	
7. Author(s) Thomas J. Smith, Curtis Hammond, Guruprasad Somasundaram, and Nikolaos Papanikolopoulos		8. Performing Organization Report No.	
9. Performing Organization Name and Address School of Kinesiology                      Dept. of Computer Science University of Minnesota                    University of Minnesota 1900 University Ave SE                    200 Union Street SE Minneapolis, MN 55455                   Minneapolis, MN 55455		10. Project/Task/Work Unit No.	
		11. Contract (C) or Grant (G) No. (c) 89261 (wo) 6	
12. Sponsoring Organization Name and Address Minnesota Department of Transportation 395 John Ireland Boulevard, Mail Stop 330 St. Paul, MN 55155		13. Type of Report and Period Covered Final Report	
		14. Sponsoring Agency Code	
15. Supplementary Notes <a href="http://www.lrrb.org/PDF/200903.pdf">http://www.lrrb.org/PDF/200903.pdf</a>			
16. Abstract (Limit: 200 words) This study evaluated the efficacy of active versus passive warnings at uncontrolled pedestrian (ped) crosswalks (Xwalks), by comparing how these two warnings types influenced behavior of drivers approaching such Xwalks. Vehicle-Xwalk interactions were observed at 18 sites with passive, continuously flashing, or ped-activated warnings, yielding 7,305 no ped present and 596 ped present interactions. Vehicle velocities and accelerations were averaged for each interaction. Findings show no significant effect of warning type on overall velocities for either interaction type. With peds present only, for average velocities at successive 5m distances from the Xwalk, a downward trend in velocities from 25 to 5m is observed for passive and active warning sites, but not for ped-activated warning sites. Various lines of evidence point to a number of sources of ambiguity regarding the salience of uncontrolled Xwalk warnings, resulting in behavioral uncertainty by drivers interacting with such warnings. Mixed findings on effects of warning type in this study point to the need for further analysis of this problem area.			
17. Document Analysis/Descriptors Uncontrolled pedestrian crosswalks; active warnings, passive warnings; vehicle velocities; vehicle accelerations and decelerations		18. Availability Statement No restrictions. Document available from: National Technical Information Services, Springfield, Virginia 22161	
19. Security Class (this report) Unclassified	20. Security Class (this page) Unclassified	21. No. of Pages 141	22. Price

# **Warning Efficacy of Active versus Passive Warnings for Unsignalized Intersection and Mid-Block Pedestrian Crosswalks**

## **Final Report**

*Prepared by*

Thomas J. Smith  
Curtis Hammond  
School of Kinesiology  
University of Minnesota

Guruprasad Somasundaram  
Nikolaos Papanikolopoulos  
Department of Computer Science  
University of Minnesota

**January 2009**

*Published by*

Minnesota Department of Transportation  
Office of Research Services  
Mail Stop 330  
395 John Ireland Boulevard  
St. Paul, Minnesota 55155-1899

This report represents the results of research conducted by the authors and does not necessarily represent the views or policies of the Minnesota Department of Transportation and/or the Center for Transportation Studies. This report does not contain a standard or specified technique.

The authors and the Minnesota Department of Transportation and/or Center for Transportation Studies do not endorse products or manufacturers. Trade or manufacturers' names appear herein solely because they are considered essential to this report.

## **Acknowledgments**

The authors would like to acknowledge the assistance of the following people whose contributions were instrumental to completion of the project.

### **Project Technical Liaison**

Debra Bloom, City of Roseville, MN

### **Mn/DOT Personnel**

Dan Warzala (Office of Research Services)

### **Project Technical Advisory Panel (TAP)**

Kenneth Haider, Dept. of Public Works, Ramsey County, MN

Mary Jackson, Office of Transit, Bicycle and Pedestrian Section, Mn/DOT

Ted Schoenecker, Washington County, MN

Paul St. Martin, Traffic and Lighting Division, Dept. of Public Works, City of Saint Paul, MN

## Table of Contents

Chapter 1. Introduction and Background.....	1
1.1. Introduction.....	1
1.2. Background.....	1
1.2.1. Scope and Terms of Reference for Project .....	3
1.2.2. Factors That Influence the Outcomes of Vehicle-Pedestrian Interactions at Uncontrolled Crosswalks .....	5
1.2.3. Relevant Findings from Other Research on Uncontrolled Pedestrian Crosswalk Warnings .....	5
1.2.4. Rationale for Project .....	8
1.3. Research Objectives and Work Plan.....	8
Chapter 2. Experimental Design and Methods .....	10
2.1. Introduction.....	10
2.2. Experimental Design.....	10
2.2.1. Characteristics of Uncontrolled Crosswalk Sites Observed .....	10
2.2.2. Independent Measures .....	16
2.2.3. Dependent Measures.....	16
2.2.4. Null Hypotheses.....	16
2.3. Methods Employed to Analyze Vehicle Interactions with Uncontrolled Crosswalks. 16	
2.3.1. Traffic Monitoring Platform .....	16
2.3.2. Data Reduction and Analysis.....	18
2.4. Experimental Protocol .....	19
2.4.1. Selecting and Surveying Uncontrolled Crosswalk Sites.....	19
2.4.2. Locating and Erecting the Camera Boom, and Configuring the Traffic Monitoring System .....	20
2.4.3. Configuring the Video Capture Software Platform .....	21
2.5. Statistical Analysis.....	22
2.6. Limitations .....	22
Chapter 3. Results .....	23
3.1. Overall Average Vehicle Velocities and Decelerations/Accelerations .....	23
3.2. Average Vehicle Velocities and Decelerations/Accelerations at Different Distances from the Crosswalk .....	23
3.3. Frequency Distributions of Average Counts for Vehicle Velocities and Decelerations/Accelerations at Different Distances from the Crosswalk.....	32
Chapter 4. Discussion, Conclusions and Recommendations .....	50
4.1. Discussion.....	50
4.1.1. Findings Regarding the Null Hypotheses .....	51
4.1.2. Conceptual HF/E Analysis of Uncontrolled Pedestrian Crosswalk Warning Systems .....	53
4.2. Conclusions.....	57
4.3. Recommendations.....	58

References.....62

Appendix A	Location of Uncontrolled Crosswalk Sites in the Twin Cities Metropolitan Area From Which Data Were Collected
Appendix B	Photographs of the 18 Acceptable Data Crosswalk Sites
Appendix C	Component List for Camera Boom Traffic Monitoring System
Appendix D	Flow Chart and Description of Software Platform
Appendix E	Photographs of Steps Involved in Erecting Camera Boom
Appendix F	Sample Site Observation Recording Form
Appendix G	Frequency Distributions of Average Vehicle Velocities and Decelerations/ Accelerations at Different Distances from the Crosswalk, Relative to Type of Crosswalk Warning

## List of Tables

Table 1. Crosswalk design and innate biological factors cited in different studies as influencing the interaction of motorists and pedestrians at uncontrolled crosswalks.....	6
Table 2. Descriptions of uncontrolled crosswalk sites observed. ....	11
Table 3. Number of vehicle-crosswalk and vehicle-pedestrian interactions recorded from acceptable data sites.....	15
Table 4. Statistical summary of interactions observed for 18 acceptable data sites. ....	15
Table 5. Significant differences (by paired t-test) in average vehicle velocities at successive distances from the crosswalk between vehicle-crosswalk and vehicle-pedestrian interactions. ....	28
Table 6. Significant differences (by paired t-test) in average vehicle velocities measured at different distances from the crosswalk, for vehicle-crosswalk and vehicle-pedestrian interactions. ....	29
Table 7. Significant differences (by paired t-test) in average vehicle decel values at successive distances from the crosswalk between vehicle-crosswalk and vehicle-pedestrian interactions. ....	30
Table 8. Significant differences (by paired t-test) in average vehicle decel values measured at different distances from the crosswalk, for vehicle-crosswalk and vehicle-pedestrian interactions.....	31
Table 9. Average counts of velocities observed ( $\pm 1$ SD) at 82.0 ft (25 m) from the crosswalk, in ten different velocity ranges, for vehicle-crosswalk and vehicle-pedestrian interactions at sites with three different types of warnings.....	33
Table 10. Levels of significance observed, based on univariate ANOVA of main and interactive effects of type of interaction, type of warning, distance from crosswalk, and velocity or decel/ accel range, on average velocity and decel/accel counts.....	36

## List of Figures

Figure 1. Schematic of camera boom and traffic monitoring system. ....	17
Figure 2. Photograph of camera boom erected at an observation site. ....	18
Figure 3. Close-up of cameras affixed to pan-and-tilt mounts at apex of boom. ....	19
Figure 4. Overall average vehicle velocities (averaged from 82.0 ft to 16.4 ft adjacent to crosswalk) for vehicle-crosswalk (black bars) and vehicle-pedestrian (white bars) interactions, grouped by type of warning (passive; active; pedestrian-actuated) (* p=.020).....	24
Figure 5. Overall average vehicle velocities for different types of warning (passive; active; and pedestrian-actuated - black, gray, and white bars respectively), grouped by type of interaction (vehicle-crosswalk interactions - left histograms; vehicle-pedestrian interactions - right histograms).....	25
Figure 6. Overall average vehicle decel/accel values (averaged from 82.0 ft to 16.4 ft adjacent to crosswalk) for vehicle-crosswalk (black bars) and vehicle- pedestrian (white bars) interactions, grouped by type of warning (passive; active; pedestrian-actuated).....	26
Figure 7. Overall average vehicle decel/accel values for different types of warning (passive; active; and pedestrian-actuated - black, gray, and white bars respectively), grouped by type of interaction (vehicle-crosswalk interactions - left histograms; vehicle-pedestrian interactions - right histograms).....	27
Figure 8. Average vehicle velocities for vehicle-crosswalk interactions at successive 16.4 ft distances from the crosswalk, for passive (squares), active (diamonds), and pedestrian-actuated (triangles) warning sites. To aid visual clarity of the graph, each 95% confidence interval value has been divided by a factor of 5. ....	28
Figure 9. Average vehicle velocities for vehicle-pedestrian interactions at successive 16.4 ft distances from the crosswalk, for passive (squares), active (diamonds), and pedestrian-actuated (triangles) warning sites. To aid visual clarity of the graph, each 95% confidence interval value has been divided by a factor of 5. ....	29
Figure 10. Average vehicle decel values for vehicle-crosswalk interactions at successive 16.4 ft distances from the crosswalk, for passive (squares), active (diamonds), and pedestrian-actuated (triangles) warning sites. To aid visual clarity of the graph, each 95% confidence interval value has been divided by a factor of 4. ....	30
Figure 11. Average vehicle decel values for vehicle-pedestrian interactions at successive 16.4 ft distances from the crosswalk, for passive (squares), active (diamonds), and pedestrian-actuated (triangles) warning sites. To aid visual clarity of the graph, each 95% confidence interval value has been divided by a factor of 4. ....	31
Figure 12. Graphical depiction of data in Table 9. Average counts of velocities observed at 82.0 ft (25 m) from the crosswalk, in ten different velocity ranges, for vehicle-crosswalk (first 10 sets of histograms) and vehicle-pedestrian (second 10 sets of histograms) interactions, at sites with three different types of warnings.....	35
Figure 13. Distribution of average counts for vehicle velocities observed in ten different velocity ranges at five different distances from the crosswalk, for vehicle-crosswalk interactions at passive crosswalk warning sites. ....	38

Figure 14. Distribution of average counts for vehicle velocities observed in ten different velocity ranges at five different distances from the crosswalk, for vehicle-pedestrian interactions at passive crosswalk warning sites.....	39
Figure 15. Distribution of average counts for vehicle velocities observed in ten different velocity ranges at five different distances from the crosswalk, for vehicle-crosswalk interactions at active crosswalk warning sites. ....	40
Figure 16. Distribution of average counts for vehicle velocities observed in ten different velocity ranges at five different distances from the crosswalk, for vehicle-pedestrian interactions at active crosswalk warning sites.....	41
Figure 17. Distribution of average counts for vehicle velocities observed in ten different velocity ranges at five different distances from the crosswalk, for vehicle-crosswalk interactions at pedestrian-actuated crosswalk warning sites.....	42
Figure 18. Distribution of average counts for vehicle velocities observed in ten different velocity ranges at five different distances from the crosswalk, for vehicle-pedestrian interactions at pedestrian-actuated crosswalk warning sites. ....	43
Figure 19. Distribution of average counts for vehicle decel/accel values observed in nine different decel/accel ranges at five different distances from the crosswalk, for vehicle-crosswalk interactions at passive crosswalk warning sites. ....	44
Figure 20. Distribution of average counts for vehicle decel/accel values observed in nine different decel/accel ranges at five different distances from the crosswalk, for vehicle-pedestrian interactions at passive crosswalk warning sites.....	45
Figure 21. Distribution of average counts for vehicle decel/accel values observed in nine different decel/accel ranges at five different distances from the crosswalk, for vehicle-crosswalk interactions at active crosswalk warning sites. ....	46
Figure 22. Distribution of average counts for vehicle decel/accel values observed in nine different decel/accel ranges at five different distances from the crosswalk, for vehicle-pedestrian interactions at active crosswalk warning sites.....	47
Figure 23. Distribution of average counts for vehicle decel/accel values observed in nine different decel/accel ranges at five different distances from the crosswalk, for vehicle-crosswalk interactions at pedestrian-actuated crosswalk warning sites.....	48
Figure 24. Distribution of average counts for vehicle decel/accel values observed in nine different decel/accel ranges at five different distances from the crosswalk, for vehicle-pedestrian interactions at pedestrian-actuated crosswalk warning sites. ....	49
Figure A-1. Map of Twin Cities metropolitan area showing location of acceptable data crosswalk sites from which data were collected.....	A-1
Figure B-1. Site 1 (see table above). Passive warning crosswalk in Roseville across County Road C at Galtier St., looking west.....	B-2
Figure B-2. Site 2 (see table above). Passive warning crosswalk in St. Paul across Arlington Ave., looking east. ....	B-3
Figure B-3. Site 3 (see table above). Passive warning Gateway State Trail crosswalk in St. Paul across Arlington Ave., looking west. ....	B-4
Figure B-4. Site 4 (see table above). Passive warning crosswalk in Minneapolis, UM East Bank Campus, across Pillsbury Dr., looking east.....	B-5
Figure B-5. Site 5 (see table above). Passive warning crosswalk in Inver Grove Heights across Blaine Ave., looking south.....	B-6

Figure B-6. Site 6 (see table above). Passive warning crosswalk in Roseville across County Road B, looking east. ....	B-7
Figure B-7. Site 7 (see table above). Passive warning crosswalk in St. Paul across eastbound lanes of John Ireland Blvd., looking east.....	B-8
Figure B-8. Site 8 (see table above). Passive warning crosswalk in Minneapolis across Godfrey Parkway in Minnehaha Park, looking east. ....	B-9
Figure B-9. Site 9 (see table above). Passive warning crosswalk in Woodbury across Lake Rd., looking east. ....	B-10
Figure B-10. Site 10 (see table above). Continuously active warning crosswalk in Minneapolis across 28 <sup>th</sup> Ave. South, looking south.....	B-11
Figure B-11. Site 11 (see table above). Continuously active warning crosswalk in St. Paul across University Ave., looking west. ....	B-12
Figure B-12. Site 12 (see table above). Continuously active warning crosswalk in Coon Rapids across Northdale Blvd., looking east. ....	B-13
Figure B-13. Site 13 (see table above). Pedestrian-actuated warning crosswalk in Minneapolis across East Minnehaha Parkway, looking east. ....	B-14
Figure B-14. Site 14 (see table above). Pedestrian-actuated warning crosswalk in St. Paul across Rice St., looking south. ....	B-15
Figure B-15. Site 15 (see table above). Pedestrian-actuated warning crosswalk in Woodbury across Interlachen Parkway, looking south.....	B-16
Figure B-16. Site 16 (see table above). Pedestrian-actuated warning crosswalk in Minneapolis across West River Parkway, looking east. ....	B-17
Figure B-17. Site 17 (see table above). Pedestrian-actuated warning crosswalk in Roseville across Lexington Ave., looking south. ....	B-18
Figure B-18. Site 18 (see table above). Pedestrian-actuated warning crosswalk in Roseville across Dale St., looking south.....	B-19
Figure D-1. Flow chart for software platform. ....	D-1
Figure D-2. Snapshot of the GUI.....	D-2
Figure D-3. Specifying the crosswalk location and a region of interest.....	D-3
Figure D-4. Distance to crosswalk vs vehicle velocity for one vehicle-crosswalk interaction at Site 14 (Chap. 2, Table 3), with no pedestrian present at the crosswalk.....	D-5
Figure D-5. Distance to crosswalk versus vehicle velocity for one vehicle-crosswalk interaction at Site 14 (Chap. 2, Table 3), with a pedestrian present at the crosswalk.....	D-5
Figure E-1. Laying out camera boom components. The black and white banded pole is the calibration stick inserted (temporarily) in the hitch assembly. ....	E-1
Figure E-2. Nesting boom tube elements and judging boom height that will be required for camera viewing of the crosswalk (at this site, the crosswalk is located below the second level of the parking ramp where the observation vehicle is positioned).E-2	E-2
Figure E-3. Affixing camera mount platform to apex of camera boom, and preparing cable snake. ....	E-3
Figure E-4. Erecting camera boom after base of boom has been inserted into hitch assembly (photograph taken at different site from the site portrayed in preceding and following photographs). ....	E-4

Figure E-5. Affixing diagonal support rods to camera boom and to luggage rack of observation vehicle. ....	E-5
Figure G-1. Distribution of average counts of vehicle velocities observed in different velocity ranges at 82.0 ft (25 m) from crosswalk, for vehicle-crosswalk interactions at passive, active and pedestrian-actuated crosswalk warning sites....	G-1
Figure G-2. Distribution of average counts of vehicle velocities observed in different velocity ranges at 82.0 ft (25 m) from crosswalk, for vehicle-pedestrian interactions at passive, active and pedestrian-actuated crosswalk warning sites....	G-2
Figure G-3. Distribution of average counts of vehicle velocities observed in different velocity ranges at 65.6 ft (20 m) from crosswalk, for vehicle-crosswalk interactions at passive, active and pedestrian-actuated crosswalk warning sites....	G-3
Figure G-4. Distribution of average counts of vehicle velocities observed in different velocity ranges at 65.6 ft (20 m) from crosswalk, for vehicle-pedestrian interactions at passive, active and pedestrian-actuated crosswalk warning sites....	G-4
Figure G-5. Distribution of average counts of vehicle velocities observed in different velocity ranges at 49.2 ft (15 m) from crosswalk, for vehicle-crosswalk interactions at passive, active and pedestrian-actuated crosswalk warning sites....	G-5
Figure G-6. Distribution of average counts of vehicle velocities observed in different velocity ranges at 49.2 ft (15 m) from crosswalk, for vehicle-pedestrian interactions at passive, active and pedestrian-actuated crosswalk warning sites....	G-6
Figure G-7. Distribution of average counts of vehicle velocities observed in different velocity ranges at 32.8 ft (10 m) from crosswalk, for vehicle-crosswalk interactions at passive, active and pedestrian-actuated crosswalk warning sites....	G-7
Figure G-8. Distribution of average counts of vehicle velocities observed in different velocity ranges at 32.8 ft (10 m) from crosswalk, for vehicle-pedestrian interactions at passive, active and pedestrian-actuated crosswalk warning sites....	G-8
Figure G-9. Distribution of average counts of vehicle velocities observed in different velocity ranges at 16.4 ft (5 m) from crosswalk, for vehicle-crosswalk interactions at passive, active and pedestrian-actuated crosswalk warning sites....	G-9
Figure G-10. Distribution of average counts of vehicle velocities observed in different velocity ranges at 16.4 ft (5 m) from crosswalk, for vehicle-pedestrian interactions at passive, active and pedestrian-actuated crosswalk warning sites..	G-10
Figure G-11. Distribution of average counts of vehicle decel/accel values observed in different decel/accel ranges at 82.0 ft (25 m) from crosswalk, for vehicle-crosswalk interactions at passive, active and pedestrian-actuated crosswalk warning sites. ....	G-11
Figure G-12. Distribution of average counts of vehicle decel/accel values observed in different decel/accel ranges at 82.0 ft (25 m) from crosswalk, for vehicle-pedestrian interactions at passive, active and pedestrian-actuated crosswalk warning sites. ....	G-12
Figure G-13. Distribution of average counts of vehicle decel/accel values observed in different decel/accel ranges at 65.6 ft (20 m) from crosswalk, for vehicle-crosswalk interactions at passive, active and pedestrian-actuated crosswalk warning sites. ....	G-13
Figure G-14. Distribution of average counts of vehicle decel/accel values observed in different decel/accel ranges at 65.6 ft (20 m) from crosswalk, for vehicle-	

pedestrian interactions at passive, active and pedestrian-actuated crosswalk warning sites. ....	G-14
Figure G-15. Distribution of average counts of vehicle decel/accel values observed in different decel/accel ranges at 49.2 ft (15 m) from crosswalk, for vehicle-crosswalk interactions at passive, active and pedestrian-actuated crosswalk warning sites. ....	G-15
Figure G-16. Distribution of average counts of vehicle decel/accel values observed in different decel/accel ranges at 49.2 ft (15 m) from crosswalk, for vehicle-pedestrian interactions at passive, active and pedestrian-actuated crosswalk warning sites. ....	G-16
Figure G-17. Distribution of average counts of vehicle decel/accel values observed in different decel/accel ranges at 32.8 ft (10 m) from crosswalk, for vehicle-crosswalk interactions at passive, active and pedestrian-actuated crosswalk warning sites. ....	G-17
Figure G-18. Distribution of average counts of vehicle decel/accel values observed in different decel/accel ranges at 32.8 ft (10 m) from crosswalk, for vehicle-pedestrian interactions at passive, active and pedestrian-actuated crosswalk warning sites. ....	G-18
Figure G-19. Distribution of average counts of vehicle decel/accel values observed in different decel/accel ranges at 16.4 ft (5 m) from crosswalk, for vehicle-crosswalk interactions at passive, active and pedestrian-actuated crosswalk warning sites. ....	G-19
Figure G-20. Distribution of average counts of vehicle decel/accel values observed in different decel/accel ranges at 16.4 ft (5 m) from crosswalk, for vehicle-pedestrian interactions at passive, active and pedestrian-actuated crosswalk warning sites. ....	20

## Abbreviations, Acronyms and Definitions

accel	acceleration
active pedestrian crosswalk warning	a warning design featuring a flashing yellow beacon either affixed to a passive roadway shoulder warning sign, or suspended above the roadway
ADA	Americans with Disabilities Act
ADT	average daily traffic
AIRVL	1UM Artificial Intelligence Robotics and Vision Laboratory
ANOVA	analysis of variance
Bonferroni procedure	statistical procedure used to adjust univariate ANOVA, with >1 dependent measures involved, to circumvent Type I errors [17]
crash traffic system	in the traffic community, a physical collision involving two or more entities of a traffic system
C++	a computer programming language
continental crosswalk warning design	passive crosswalk roadway warning markings featuring a series of thick transverse line markings
CTS	University of Minnesota Center for Transportation Studies
decel	deceleration
df	degrees of freedom
DOT	Department of Transportation
Excel	Microsoft spreadsheet program
F / F-crit	value for F statistic / critical F value for $p < .05$ .
FHWA	Federal Highway Administration
first-order effect	2-way interactive effect of an independent on a dependent variable, as established by ANOVA
ft	feet/foot
HF; HF/E	human factors; human factors/ergonomics
hr	hour
in	inch
km	kilometers
kph	kilometers per hour
m	meters
MATLAB	a software platform specialized for use in experimental laboratory programming environments
mi	miles
mid-block pedestrian crosswalk	an uncontrolled crosswalk that crosses a roadway in the middle of a block
min	minutes
mm	millimeters
Mn/DOT	State of Minnesota Department of Transportation
mph	miles per hour
MUTCD	Manual on Uniform Traffic Control Devices

N/A	not applicable
no.	number
unsignalized intersection	an intersection without active traffic control devices
NTSB	National Transportation Safety Board
p	probability
passive pedestrian crosswalk warning	a warning design featuring roadway markings accompanied by yellow pedestrian warning signs facing oncoming traffic on both roadway shoulders, in close proximity to the markings
pedestrian-actuated crosswalk warning	a warning design featuring a button mounted on a standard supporting a yellow flashing beacon and the accompanying passive sign, that must be actuated by a pedestrian before the beacon becomes active.
PIEV	the total time needed by a motorist to perceive and complete a reaction to a sign assumed to represent the sum of the times necessary for Perception, Identification (understanding), Emotion (decision making), and Volition (execution of decision)
<i>post hoc</i> analysis	the data analysis procedure employed to investigate and interpret the basis of statistically significant interactive effects revealed by ANOVA
SD	standard deviation
sec	seconds
second-order effect	3-way interactive effect of an independent on a dependent variable, as established by ANOVA
signalized intersection	an intersection equipped with traffic control devices
SL	speed limit
SPSS	software platform used for statistical analysis of data
standard crosswalk warning design	passive crosswalk roadway warning markings featuring two parallel line markings
t	time
TAP	Technical Advisory Panel
TCD	traffic control device
type I error	statistical analysis indicates significant effect, when in fact the effect is due to chance
UM	University of Minnesota
uncontrolled crosswalk	a crosswalk at a roadway site without traffic control devices
yrs	years
zebra crosswalk warning design	passive crosswalk roadway warning markings featuring a series of diagonal line markings

## Executive Summary

This study addressed the warning efficacy of *active* versus *passive* warnings at *uncontrolled* crosswalks. A crosswalk at a roadway site without traffic control devices (i.e., unsignalized intersection or mid-block sites) is defined as an uncontrolled crosswalk. In this study: (1) *passive warning* crosswalk sites featured roadway markings accompanied by yellow pedestrian warning signs facing oncoming traffic on both roadway shoulders; and (2) *active warning* crosswalk sites featured passive warnings accompanied by flashing yellow beacons either affixed to the roadway shoulder signs, or suspended above the roadway. Two types of active crosswalk warning sites, with *continuously flashing* or with *pedestrian-actuated* beacons, were evaluated. At pedestrian-actuated crosswalk warning sites, a button mounted on the standard supporting the yellow flashing beacon and accompanying passive sign must be actuated by a pedestrian before the beacon becomes active. The relative influence of these three types of uncontrolled crosswalk warnings---passive, continuously active, and pedestrian-actuated---on the behavior of motorists approaching crosswalks equipped with such warnings was evaluated.

Project objectives were to carry out: (1) a literature review of research findings relevant to uncontrolled crosswalk warning systems; (2) a field study of the relative warning efficacy of active versus passive warnings at selected suburban and urban uncontrolled crosswalks in the Twin Cities metropolitan area; and (3) development of recommendations to the Minnesota surface transportation community regarding the relative warning benefits of active versus passive uncontrolled crosswalk warnings, and design alternatives for low-cost crosswalk warnings.

*Experimental design and methods.* From July through November, 2007, interactions of vehicles with uncontrolled crosswalks (no pedestrians present), and with pedestrians at uncontrolled crosswalks, were observed at 23 sites in the greater Twin Cities metropolitan area. Usable data were retrieved from 18 of these sites. Roadway speed limits (SLs) for all sites were 25, 30, or 35 mph. Observation periods ranged from 50 to 110 min in duration during daylight hours, and were scheduled at times of day with predicted crosswalk pedestrian traffic.

For all sites, a total of 7,305 vehicle-crosswalk, and 596 vehicle-pedestrian, interactions were observed. The three warning types---passive, continuously active, and pedestrian-actuated---accounted respectively for 40.4, 23.8 and 35.8 percent of the vehicle-crosswalk interactions, and 21.1, 32.2 and 46.6 percent of the vehicle-pedestrian interactions, observed.

Independent measures for the study are the type of uncontrolled crosswalk warning, and the presence or absence of a pedestrian at a crosswalk.

Two categories of dependent measures were calculated for the study. The first comprises average velocities and deceleration/acceleration (decel/accel) values of vehicles approaching the crosswalk for each vehicle-crosswalk and vehicle-pedestrian interaction. The second is frequency distributions of average counts of vehicle velocities and decel/accel values observed for 10 different velocity ranges and nine different decel/accel ranges respectively.

The null hypotheses for the study are that no main or interactive effects of warning type or pedestrian presence/absence on the dependent measures will be observed.

Two methodological innovations were developed for the project to support data collection and analysis. The first is a modular, portable camera boom system designed as a low-cost alternative to using a bucket truck for traffic monitoring purposes. The second is a computer vision software platform that automatically computes distances, velocities, and accelerations of moving vehicles, as well as vehicle and pedestrian counts, across successively recorded 30

frame/sec camera images. For each vehicle-crosswalk and vehicle-pedestrian interaction observed, computed data are written to a spreadsheet and dependent measures calculated.

*Results.* Project findings are mixed regarding support for the null hypothesis of the study.

Two findings indicate that warning condition (i.e., passive versus active crosswalk warning type) has no significant effect on the dependent measures. The most prominent such finding is that no significant differences in average overall vehicle velocities and decel/accel values are observed across warning condition, for either pedestrian absent or pedestrian present vehicle-crosswalk interactions.

In contrast, two findings indicate that warning condition does have a significant effect on the dependent measures. These findings pertain to frequency distributions of average counts of observed vehicle velocity and decel/accel values. For example, based on frequency distributions of average counts of vehicle velocities, for the seven lowest average velocity ranges evaluated in this manner, average counts for active crosswalk warning sites, for both pedestrian absent and pedestrian present vehicle-crosswalk interactions, often are higher than those for passive crosswalk warning sites. This finding indicates that drivers approaching uncontrolled crosswalks with active warnings tend to adopt somewhat lower vehicle velocities, relative to drivers approaching crosswalks with passive warnings. This result accords with the assumption that because an active uncontrolled crosswalk warning is more noticeable than a passive uncontrolled crosswalk warning, drivers interacting with active warnings at uncontrolled crosswalk sites are more likely to display more cautious driving behavior.

Four findings indicate that interaction condition (i.e., pedestrian absent versus pedestrian present vehicle-crosswalk interactions) has no significant effect on the dependent measures. The most prominent of these findings is that, for average overall vehicle velocities and decel/accel levels, no significant differences are observed between pedestrian absent versus pedestrian present vehicle-crosswalk interactions, for either passive or active crosswalk warning sites.

In contrast, two findings indicate that interaction condition does have a significant effect on the dependent measures. The most prominent such finding is that, for average overall vehicle velocities for pedestrian-actuated warning sites, levels for vehicle-crosswalk interactions are significantly higher than those for vehicle-pedestrian interactions. This finding indicates that drivers approaching uncontrolled crosswalks with pedestrian-actuated warnings tend to adopt somewhat lower vehicle velocities when a pedestrian is present, relative to drivers approaching such crosswalks when a pedestrian is not present. This result accords with the assumption that because the presence of a pedestrian at an uncontrolled crosswalk has greater salience for drivers than when no pedestrian is present, drivers interacting with a pedestrian at an uncontrolled crosswalk are more likely to display more cautious driving behavior, relative to interactions when a pedestrian is not present.

*Conclusions.* The mixed results outlined above supports the following conclusions.

- There is an ambiguity inherent to the salience of warning signs at uncontrolled pedestrian crosswalks, in that the warning refers to an event (i.e., arrival of a pedestrian in proximity to the crosswalk) that may or may not actually occur at the time a given motorist approaches the crosswalk. Because of this ambiguity, we hypothesize that most motorists approaching an uncontrolled crosswalk tend to pay more attention to whether or not a pedestrian is present in proximity to the crosswalk, rather than to the type of crosswalk warning. In other words, the most critical salient feature of an uncontrolled crosswalk for a motorist approaching the crosswalk is the presence or absence of a pedestrian, rather than the crosswalk warning condition. We believe this ambiguity accounts for the mixed results observed in this study.

- The previous conclusion suggests that the efficacy of warnings at uncontrolled crosswalks in protecting the safety of users of such crosswalks may be inherently limited. If the presence of a pedestrian at an uncontrolled crosswalk is the most critical salient feature of the crosswalk, then pedestrian-actuated warnings should be more effective than other types of warnings in terms of promoting more cautious driving behavior of motorists interacting with uncontrolled crosswalks. However, other studies have shown that pedestrian or bicyclist users of uncontrolled crosswalks equipped with active pedestrian-actuated warnings usually do not actually activate the warning in preparation for crossing.
- The two foregoing conclusions suggest that pedestrian-actuated warnings at uncontrolled crosswalks likely will achieve their full potential as effective warnings only if pedestrians approaching in proximity to such crosswalks are no longer required to play an active role in actually actuating the warning. This idea leads to three key recommendations of this study.

*Recommendations.* At the outset of this project, two contrasting recommendations growing out of the findings arguably could be anticipated. If the null hypothesis was supported by the findings, a conceivable recommendation would be to install only passive warning systems at uncontrolled crosswalks, given that active warning systems are no more effective than passive warning systems in influencing the behavior of drivers interacting with uncontrolled crosswalks.

If the null hypothesis was not supported by the findings, a contrasting recommendation would be to maintain the status quo---that is, retain the current system that features use of both passive and active crosswalk warnings at uncontrolled crosswalks.

Actual findings do not lend strong support to either of these contrasting possibilities, because support for the null hypotheses is mixed. This raises the question as to whether a recommended approach to warning design at uncontrolled crosswalks might be identified that combines the virtues of both cost savings and pedestrian safety benefits.

The following 3 recommendations offer an approach for uncontrolled crosswalk active warning system design that: (1) emphasizes the presence of a pedestrian in proximity to the crosswalk, not the presence of the warning itself; and (2) no longer requires pedestrians approaching such crosswalks to play an active role in actually actuating the warning. Adaptation of the automated pedestrian detection software used with this project offers both a feasible and a practical approach for achieving these goals.

**Recommendation 1.** Eliminate the requirement that pedestrians preparing to cross an uncontrolled crosswalk equipped with a pedestrian-actuated warning must engage in intentional behavior (i.e., depressing a control button) in order to activate the warning.

**Recommendation 2.** To implement Recommendation 1, explore the feasibility and practicality of adapting computer vision technology to enable automated detection of pedestrians approaching uncontrolled crosswalks, and of using intelligent decision-making software linked to such technology to automatically actuate an active warning system situated at the crosswalk when pedestrians are detected approaching the crosswalk.

**Recommendation 3.** Consider: (1) replacing current continuously active and pedestrian-actuated warnings at uncontrolled crosswalks with active warnings that are automatically actuated only when a pedestrian is detected; and (2) evaluating the impact of this change on driver behavior at uncontrolled crosswalks. Depending upon cost and traffic engineering considerations, replacing passive warnings at selected uncontrolled crosswalks with automatically actuated active warnings also should be considered.

# Chapter 1

## Introduction and Background

### 1.1. Introduction

This is the final report for a study conducted by the School of Kinesiology and the Department of Computer Science at the University of Minnesota (UM) to carry out an evaluation of the warning efficacy of *active* versus *passive* warnings at *uncontrolled* crosswalks. A crosswalk at a roadway site without traffic control devices---namely unsignalized intersection or mid-block sites---is defined as an uncontrolled crosswalk. In this study: (1) *passive warning* crosswalk sites featured roadway markings accompanied by yellow pedestrian warning signs facing oncoming traffic on both roadway shoulders, in close proximity to the markings [18]; and (2) *active warning* crosswalk sites featured passive warnings accompanied by flashing yellow beacons either affixed to the roadway shoulder signs, or suspended above the roadway. Two types of active crosswalk warning sites, with continuously flashing or with pedestrian-actuated beacons, were evaluated.

This study evaluated the relative influence of these three types of uncontrolled crosswalk warnings---passive, continuously active, and pedestrian-actuated---on the behavior of motorists approaching crosswalks equipped with such warnings. The study was carried out under a contract administered by the State of Minnesota Department of Transportation (Mn/DOT) and the UM Center for Transportation Studies (CTS). The report outlines the background to the project, describes research methods and results, and presents conclusions and recommendations supported by the findings.

The report is divided into four chapters. Chapter 1 introduces and summarizes the background for the project, as well as the research objectives and work plan. Chapter 2 describes the experimental design and methods, and Chapter 3 the findings. Chapter 4 discusses some of the implications of the study, and summarizes conclusions and recommendations supported by the findings.

### 1.2 Background

Prior to the industrial revolution, the two preeminent modes of land-based transportation were walking and horse transport. The former was by far the most prevalent. Even in pre-industrial times, however, pedestrian safety was of concern. Fruin [1] describes various strategies used by city planners in pre-industrial times to limit pedestrian-vehicle interactions, such as prohibiting vehicle access to city centers, barriers to separate pedestrians from roadways, and central city plazas dedicated to pedestrians.

The advent of the motor vehicle dramatically altered the pedestrian safety equation with regard to pedestrian-vehicle interactions by substantially increasing the risk of severe injuries and fatalities to pedestrians resulting from pedestrian-vehicle crashes. Consequently, pedestrian safety has long been a matter of concern for the surface traffic community [21]. As the 20<sup>th</sup> century progressed, however, increased motor vehicle usage along with a number of other factors (such as the expansion of suburbia along with geographic separation of workplaces from residential neighborhoods) was associated with a steady decline in pedestrian activity. Based on 2006 U.S. census statistics, the share of pedestrian work trips has declined by almost 25 percent in the past decade, whereas bicycle use appears to be on the rise [2, p. 2]. However, trend data for walking and bicycling activities over the past three decades [28, p. 8-1] indicate that: (1) between 1980 and 1990 the percentage of commuting trips made by walking and bicycling

dropped from 6.7 percent to 4.4 percent; but (2) total walking trips rose from 7.2 percent of all trips in 1990 to 8.7 percent in 2001. Based on a national survey of the driving public, 27.3 percent reported riding a bicycle, and 78.7 percent reported walking or running outdoors, during the summer of 2002 [2, p. 2].

Pedestrian fatalities have dropped gradually over the past 20 years, from about 7,000 to about 5,000 annually [28, p. 8-1]. In 2005, 4,881 pedestrians died and about 64,000 were injured in traffic crashes in the U.S., accounting for 10 percent of total traffic fatalities and just over two percent of total injuries [Table 53 in 29]. For bicyclists, the comparable fatality and injury percentages for 2005 both are 1.7 percent [3]. In Minnesota for the same year, pedestrian and bicycle fatalities accounted, respectively, for 7.9 and 1.25 percent of total motor vehicle crash fatalities in the state [4]. A study in the 1990s of crash types for more than 5,000 pedestrian crashes in six U.S. states found that mid-block incidents were the second most prevalent crash type, accounting for 26.5 percent of all such crashes [30, p. 158].

In the past two decades, walking has received increased attention throughout the U.S. and elsewhere as a mode of transportation. Thus, in 1994 the U.S. DOT proposed two goals to the U.S. Congress [31, p. 1-2], namely that: (1) total U.S. trips made by bicycling and walking should double, from 7.9 percent to 15.8 percent of all travel trips; and (2) the number of bicyclists and pedestrians killed or injured in traffic crashes should be reduced by 10 percent. In October, 2007, the U.S. joined 41 other countries in sponsoring the International Walk to School Month, a global event in which the entire month was devoted to celebrating the many benefits of walking for children, parents, school teachers and community leaders [32].

The State of Minnesota is a leader in promoting increased facilities and safety for pedestrians and bicyclists [2], as reflected in a series of recent news reports. The City of Minneapolis ranks second only to Portland, OR, in the number of people who bike to work [5]. Both Minneapolis and other counties and municipalities in the Twin Cities metropolitan area have mounted initiatives to encourage more walking and biking [6-9]. Seventeen schools in Minnesota have won federal grants to encourage more walking or biking to school by school children [10].

Growing interest in walking and bicycling activity has prompted research attention, both federally and in Minnesota, to the appropriate design of pedestrian and bicycling facilities for both safety and usability [2,11-15]. The project described in this report represents an additional contribution to this effort. The goal of this project is to ascertain if active warning signs at uncontrolled crosswalks (i.e., flashing lights that either flash continuously, or are pedestrian-actuated) are any more effective than passive warnings at uncontrolled crosswalks (i.e., roadway markings that may or may not be accompanied by warning signs) in influencing driver behavior in approaching such crosswalks.

To achieve this goal, digital camera images of the interaction of vehicles with pedestrians and bicyclists were collected at selected uncontrolled crosswalks in the Minnesota Twin Cities metropolitan area. A customized computer vision software platform was used to calculate selected dependent measures for each vehicle-crosswalk and vehicle-pedestrian interaction that was imaged during the observation period. Chapter 2 provides details of the methods employed for these tasks, along with descriptions of the experimental design and protocol, data reduction, and the statistical approach. Sections below provide: (1) scope and terms of reference for project (Section 1.2.1); (2) factors that influence the outcomes of vehicle-pedestrian interactions at uncontrolled crosswalks (Section 1.2.2); (3) relevant findings from other research on uncontrolled pedestrian crosswalk warning systems (Section 1.2.3); (4) rationale for project (Section 1.2.4); and (5) research objectives and work plan (Section 1.3).

### 1.2.1. Scope and Terms of Reference for Project

This section is concerned with the appropriate terminology for crosswalks and crosswalk warnings that will be employed for the remainder of this report, and the scope of the analysis carried out by the project.

Research carried out by this project evaluated a selected series of uncontrolled pedestrian crosswalks in the Minnesota Twin Cities metropolitan area. The decision to limit the scope of the analysis in this manner, and selection of crosswalks to evaluate, was carried out in consultation with the Mn/DOT Technical Advisory Panel (TAP) for the project. Paragraphs below address questions regarding: (1) the legal definition of a crosswalk; (2) applicable terminology for pedestrian crosswalks; (3) design specifications for crosswalk warnings; and (4) the evaluation of both pedestrian and bicycle traffic in crosswalks.

*What is a crosswalk?* Section 1-112 of the 2000 *Uniform Vehicle Code and Model Traffic Ordinance* [12, p. 2;16] defines a crosswalk as:

‘(a) That part of a roadway at an intersection included within the connections of the lateral lines of the sidewalks on opposite sides of the highway measured from the curbs, or in the absence of curbs, from the edges of the traversable roadway; and in the absence of a sidewalk on one side of the roadway, the part of a roadway included within the extension of the lateral lines of the existing sidewalk at right angles to the centerline.

(b) Any portion of a roadway at an intersection or elsewhere distinctly indicated for pedestrian crossing by lines or other markings on the surface.’

Thus, a crosswalk at an intersection is defined as the extension of the sidewalk or the shoulder across the intersection, regardless of whether it is marked or not. The only way a crosswalk can exist at a mid-block location is if it is marked. Most jurisdictions have crosswalk laws that make it legal for pedestrians to cross the street at any intersection, whether marked or not, unless the pedestrian crossing is specifically prohibited.

*What terminology applies to pedestrian crosswalks?* This project is concerned exclusively with evaluating the interaction of vehicles with pedestrians and bicyclists at uncontrolled crosswalks. There is some inconsistency in the terminology applied to pedestrian crosswalks at uncontrolled locations. Zegeer et al. [12] use the term ‘uncontrolled locations’ for these locations---this terminology also is employed in this report. Fitzpatrick et al. [14] use the term ‘unsignalized crossings’ to refer to these locations. The term ‘signalized’ potentially can refer to the existence of a traffic control signal at an intersection (see [17] for an example of this usage), or to the existence of an active warning system (i.e., flashing lights) at a pedestrian crosswalk. For purposes of consistency, and to avoid the potential for confusion created by this dual usage, the following terminology will be employed throughout the remainder of this report.

- The terms signalized and unsignalized exclusively refer to the traffic warning system at any given intersection (i.e., traffic control signals, or no traffic control signals). This usage is consistent with that employed in the project title. For purposes of this report, an unsignalized intersection also is assumed to lack a stop sign (that is, pedestrian crosswalks at unsignalized intersections with a stop sign are not evaluated).
- The terms active and passive will be used to refer to the type of pedestrian crosswalk warning. An active crosswalk warning has some sort of flashing light warning. A passive crosswalk warning has roadway markings plus warning signage (Section 1.1).

- The terms unsignalized intersection and mid-block refer to the location of any given uncontrolled pedestrian crosswalk. A mid-block crosswalk location is any location that is not situated right at an intersection of two roadways.

*What are applicable design specifications for uncontrolled pedestrian crosswalk warnings?*

According to the Minnesota Manual on Uniform Traffic Control Devices (MnMUTCD) [18], the following design specifications germane to this project apply to uncontrolled pedestrian crosswalk warning installations.

- A passive in-street pedestrian crosswalk sign is a regulatory sign, emplaced on the street, that is intended to remind drivers that a pedestrian has the legal right-of-way upon entering a crosswalk. This sign should only be used at mid-block locations or at intersection approaches not controlled by a stop sign or a traffic control signal.
- A passive pedestrian or bicycle warning sign is emplaced on the roadway shoulder immediately adjacent to the crosswalk, and is intended to warn drivers approaching the crosswalk of the possibility of an unexpected entry of a pedestrian or a bicycle into the crosswalk. A passive pedestrian warning sign is categorized as a non-vehicular warning sign. A passive bicycle warning sign is categorized as a vehicular warning sign.
- For pedestrian crosswalks at uncontrolled locations, crosswalk markings serve to alert drivers of the pedestrian crossing point. At mid-block locations, crosswalk markings legally establish the crosswalk. Because drivers typically do not expect to encounter mid-block crosswalks, crosswalk markings should be accompanied by pedestrian warning signs (above) on the roadway shoulder. Three different alternative designs for crosswalk roadway markings are specified, with design terms based on [12]: (1) a series of thick transverse line markings (continental design); (2) a series of diagonal line markings (zebra design); or (3) two parallel line markings (standard design).
- Active pedestrian crosswalk warning signs should be installed at crosswalks where traffic volume is so heavy that pedestrians may experience excessive delay in crossing. At non-intersection crosswalks, the active warning may be either pedestrian-actuated or continuously flashing, and should be accompanied by suitable passive signs and pavement markings.
- An active pedestrian crosswalk warning sign consists of a flashing beacon, defined as a highway traffic signal, with one or more signal sections, that operates in a flashing mode.
- With this project, all crosswalks with active warning signs evaluated are located at mid-block locations; and located either on the roadway shoulder or suspended over the roadway.

*Why evaluate interactions of vehicles with both pedestrians and bicyclists?* According to Minnesota law [19; Minnesota Statute 169.222], bicycle operators are subject to the same laws and regulations as motor vehicle operators. That is, by law bicyclists are not pedestrians, a point driven home by a recent favorable court decision regarding a so-called trespass by a bicyclist onto Minneapolis International Airport property [20]. This raises the question of why vehicle interactions with both pedestrians and bicyclists at uncontrolled crosswalks are evaluated by this project. The rationale for this approach is as follows: (1) for a number of Twin Cities metropolitan area crosswalks evaluated, both pedestrians and bicyclists were observed using the same crosswalk; (2) recent attention to alternative modes of transportation encompasses public interest and investment in both walking and bicycling (above); and (3) the Minnesota MUTCD states that [18, Section 4C.1], ‘bicyclists who are clearly using pedestrian facilities are usually counted as pedestrians.’

### **1.2.2. Factors That Influence the Outcomes of Vehicle-Pedestrian Interactions at Uncontrolled Crosswalks**

A number of studies have examined the question of what factors influence outcomes of vehicle-pedestrian interactions at different types of pedestrian crosswalks. Table 1 summarizes findings from 6 such studies that are concerned specifically with factors influencing outcomes of vehicle-pedestrian interactions at uncontrolled crosswalks. Studies cited in Table 1 report four different outcome measures: (1) pedestrian crash frequencies; (2) the rate at which motorists yield to pedestrians using a crosswalk; (3) the likelihood of pedestrian use of a crosswalk; and (4) pedestrian perceptions of the level of crosswalk safety.

Two classes of factors are specified in Table 1, namely those related to the environmental design features of the crosswalk, and those related to the innate biological characteristics of the pedestrian. The synopsis in Table 1 supports the following conclusions: (1) observations of significant outcome effects for the number of roadway lanes, and for age, are somewhat consistent across the six different studies; (2) however, no one factor is cited across all six studies as having a significant outcome effect; and (3) across the six studies, there are inconsistent findings for traffic speed or SL having a significant effect on the outcome measures.

### **1.2.3. Relevant Findings from Other Research on Uncontrolled Pedestrian Crosswalk Warnings**

There has been considerable research attention to the question of pedestrian safety at uncontrolled crosswalks, prompted no doubt by: (1) the prevalence of this class of crosswalk; (2) concern that, relative to controlled crosswalks, uncontrolled crosswalks pose an elevated risk to pedestrian safety; and (3) the fact that mid-block incidents represent the second-most prevalent pedestrian crash type, accounting for about one-fourth of such crashes [30, p. 158].

The largest body of evidence generated by this research pertains to the relative impact of marked versus unmarked pedestrian crosswalks (i.e., crosswalks with passive roadway markings, versus crosswalks with no warnings at all) on pedestrian safety at uncontrolled crosswalks. Literature sources for this evidence are extensively reviewed in [22, Appendix C, pp. 18-33; Appendix E, pp. 73-75], and feature the following key findings:

- controlling for pedestrian usage, compared with unmarked crosswalks, pedestrian crash levels at marked crosswalks were higher by: (1) two- to three-fold [33]; (2) 3.2- to 3.7-fold [34]; and (3) 3.6-fold [35];
- removal of crosswalk markings resulted in a 61 percent decline in pedestrian crashes [36];
- there was no significant effect of marked versus unmarked crosswalks on pedestrian crashes for: (1) two-lane roads; (2) multilane roads without raised medians and with average daily traffic (ADT) levels below 12,000; and (3) multilane roads with raised medians and with ADT levels below 15,000 [12];
- the pedestrian crash rate at marked crosswalks was significantly higher than that at unmarked crosswalks for multilane roads with: (1) no raised medians and ADTs above 12,000; and (2) raised medians and ADTs above 15,000 [12].

These findings support the conclusion that, under most conditions, marked crosswalks are less safe than unmarked crosswalks in terms of pedestrian crashes. One key exception, however, is for two-lane roads, for which no significant difference in crash rates was observed [12].

Table 1. Crosswalk design and innate biological factors cited in different studies as influencing the interaction of motorists and pedestrians at uncontrolled crosswalks.

<b>Study</b>	<b>Primary Crosswalk Design Factors Cited</b>	<b>Innate Biological Factors Cited</b>	<b>Comments</b>
[12]	Number of roadway lanes Pedestrian traffic volume Vehicle traffic volume Presence or lack of median Time of day Lighting conditions	Age	For marked crosswalks, higher incidence of pedestrian crashes observed : (1) at higher pedestrian and vehicle volumes; (2) on roadways with more than two lanes and lacking a median; (3) between 10:00 AM and midnight; (4) during daylight hours, or in the dark at lighted crosswalks; and (5) with elderly pedestrians. No effect of posted vehicle SL on crash incidence observed.
[14]	Number of roadway lanes Posted vehicle SL		At uncontrolled crosswalks, the percentage of motorist yielding to pedestrians is: (1) slightly higher for 4- relative to 2-lane roads, for crosswalks with overhead active flashing warnings; and (2) is substantially higher for 25 relative to 35 mph SL roadways, for crosswalks with passive warnings.
[22, p. 181]	Vehicle traffic volume Turning traffic Traffic speed Availability of an alternate crossing	Presence of disabled pedestrians	Factors cited based on questionnaire surveys of 247 pedestrians at 7 different crosswalk sites.
[24]	Number of roadway lanes	Age	Consistently significant effects for mid-block pedestrian crash data collected from 3 locales show that crash frequencies: (1) increase as the number of roadway lanes increase; and (2) are higher for younger (5-14 years) and older (>65 years) pedestrians compared with those of intermediate age.
[25]	Crosswalk crossing distance Vehicle traffic volume		A multiple regression model for predicting pedestrian street-crossing behavior shows that, for mid-block crosswalks, crossing becomes significantly less likely the greater the crossing distance and the traffic volume.
[26]	Time of day Month of year	Age Gender	Based on an analysis of mid-block pedestrian crashes occurring in Clark County, Nevada over a three-year period: (1) crashes occur at a higher frequency between 3:00 and 7:00 PM and during spring and fall months; and (2) males and children (<18 years) are disproportionately at risk for crashes

Given that the foregoing findings deal with a comparison of marked versus unmarked crosswalks (rather than a comparison of marked crosswalks with passive versus active warnings), what is the relevance of these findings to the present study? Three considerations are worthy of note. First, the findings summarized above indicate that the presence of a more conspicuous crosswalk warning (i.e., presence rather than lack of crosswalk markings) is not necessarily associated with pedestrian safety benefits. This seeming counterintuitive conclusion, in turn, tends to validate the present study in suggesting that conclusions about the relative safety benefits of different traffic warning system designs should be based, not upon *ad hoc* assumptions, but rather upon empirical analysis. Finally, the observation that presence or lack of markings for crosswalks across two-lane roadways had no significant effect on pedestrian crash rates may have relevance for the present study, for which two-lane roadway crosswalks represent the most prevalent type evaluated.

The present study compares and contrasts the dynamics of vehicle interactions with pedestrians at uncontrolled crosswalks with: (1) passive warnings comprising roadway markings and yellow pedestrian signs on the roadway shoulder next to the crosswalk; versus (2) active warnings comprising the same types of passive warnings plus flashing amber beacons. Is there other research that has investigated relative pedestrian safety effects of comparable types of passive and active warnings at uncontrolled crossings? Fitzpatrick et al. [22, Appendices C, D and E] review a large number of studies in which uncontrolled crosswalks were upgraded with crossing treatments aimed at mitigating the risk of pedestrian crashes, and various dependent measures related to pedestrian safety were collected before and after the upgrades were introduced. Findings from three of these studies are relevant to the present research, because the upgrade enabled a comparison of the relative influence of the same two classes of warnings noted above on vehicle-pedestrian interactions at uncontrolled crosswalks.

1. At four school crosswalks test sites with passive warnings in Phoenix, AZ, with matched control sites, adding overhead and advance flashing amber beacons to the test sites resulted in no decrease in vehicle speeds approaching the crosswalk, or in pedestrian crashes [37]. The authors conclude that, 'Flashers offer no benefit for intermittent pedestrian crossings in an urban environment. In addition, the longer a flasher operates the more it becomes part of the scenery and loses any effectiveness.'
2. One mid-block crosswalk with passive warnings in St. Petersburg, FL, was upgraded with overhead flashing amber beacons, plus one other type of active warning sign (animated scanning eyes) and two additional passive warnings (advance stop lines and motorist prompting signs) [38]. As a result of installation of these upgrades: (1) the percentage of motorists yielding to pedestrian increased from 3 to 30 percent; and (2) the percentage of vehicle-pedestrian conflicts decreased from 2 to 0.5 percent.
3. Informal studies of 25 uncontrolled crosswalks sites in Los Angeles by the Los Angeles Department of Transportation indicate that the percentage of motorists yielding to pedestrians ranges from: (1) 20 to 30 percent for crosswalks with roadway markings only; but (2) 72 to 76 percent for crosswalks with passive warnings plus overhead pedestrian-actuated amber flashing beacons [22, Appendix E, p. 69].

Collectively, findings from the three studies cited above provide a mixed view of the relative efficacy at uncontrolled crosswalks of the two types of warning designs evaluated in the present study in influencing pedestrian safety. Study 1 [37] found no safety benefit of active relative to passive warnings, whereas Studies 2 [38] and 3 [22, Appendix E, p. 69] documented a positive

benefit of active warning signage. Because the first two studies evaluated other types of active warnings in addition to flashing amber beacons at the crosswalk, warning designs evaluated in Study 3 are the most directly comparable to warning designs evaluated in the present study. This supports the prediction that, in the present study, motorists approaching pedestrians at crosswalks with active warnings are likely to behave more cautiously, relative to those approaching pedestrians at crosswalks with passive warnings.

However, no differential effect of active relative to passive warnings was observed in Study 1, even though the crossing treatment upgrade featured active flashing amber beacons deployed both at and in advance of the four crosswalks evaluated. Lack of an observed effect, in the face of enhanced conspicuity of dual (relative to single) active warnings situated both at and in advance of the crosswalk, supports the opposite prediction that, in the present study, motorists approaching pedestrians at crosswalks with active warnings are not likely to behave more cautiously, relative to those approaching pedestrians at crosswalks with passive warnings.

In summary, the studies cited above provide no clear guidance as to findings to be expected with the present study. The authors are not aware of any other research that bears directly upon the experimental design and approach employed in the present study.

#### **1.2.4. Rationale for Project**

The following considerations provide a rationale for the project.

1. As summarized in Section 1.2.3 above, findings from the limited number of prior studies that have evaluated the relative influence on pedestrian safety at uncontrolled crosswalks of active versus passive warnings, with warning designs comparable to those evaluated in the present study, provide no clear guidance as to findings to be expected with the present study. This points to the need for further empirical analysis to address this question.
2. The traffic monitoring system, plus the computer vision software platform for automated analysis of the dynamics of vehicle-pedestrian interactions, developed and applied with this project have generated a body of data concerning such interactions, as well as quantitative insight into their dynamic properties, unmatched by prior research.
3. Given that pedestrian crashes at uncontrolled crosswalks account for about one-fourth of all such crashes [30, p. 158], insight into the dynamics of vehicle-pedestrian interactions provided by this project may point to warning design factors contributing to pedestrian safety problems at uncontrolled crosswalks.
4. Research findings from this project should aid development of criteria for deployment of crosswalk warning systems in relation to different crosswalk design contexts, and thereby support more rigorous traffic engineering and budgetary decision-making by the Minnesota surface transportation community regarding crosswalk warning system design and deployment.

### **1.3. Research Objectives and Work Plan**

This project is concerned with an analysis of the warning efficacy of active versus passive warnings for uncontrolled crosswalks, in terms of the relative influence of these two types of warnings on the behavior of motorists approaching such crosswalks. Project objectives are to carry out: (1) a literature review of research findings relevant to uncontrolled crosswalk warning systems; (2) a field study of the relative warning efficacy of active versus passive warnings at selected suburban and urban uncontrolled crosswalks in the Twin Cities metropolitan area; and (3) development of recommendations to The Minnesota surface transportation community

regarding the relative warning benefits of active versus passive uncontrolled crosswalk warnings, and design alternatives for low-cost crosswalk warnings.

The following 4 tasks are specified in the project work plan: (1) literature review; (2) experimental design, comprising crosswalk site selection, formulating experimental design specifications, and developing data collection plan, logistics and methods; (3) data collection, reduction and analysis; and (4) preparation and submission of final report.

Findings obtained from the research form the basis for a series of conclusions and recommendations presented in Chapter 4, pertaining to the relative influence of active versus passive warnings on the dynamics of vehicle-pedestrian interactions at uncontrolled crosswalks, as well as to the pedestrian safety implications of deploying alternative designs for low-cost warning systems at uncontrolled crosswalks.

## **Chapter 2**

### **Experimental Design and Methods**

#### **2.1. Introduction**

Success with data collection and analysis for this research rests upon two methodological innovations, related to traffic monitoring system and automated image processing software platforms developed expressly for the project. These methods are detailed in sections below, preceded by a description of the experimental design.

#### **2.2 Experimental Design**

##### **2.2.1 Characteristics of Uncontrolled Crosswalk Sites Observed**

From July through November, 2007, interactions of vehicles with uncontrolled crosswalks (no pedestrians present), and with pedestrians at uncontrolled crosswalks, were observed at 24 crosswalk sites in the Twin Cities metropolitan area (this area comprises the cities of Minneapolis and Saint Paul, MN, and surrounding communities). Table 2 provides a description of each of these sites, with the date of observation (Column 1), the type of crosswalk (Column 2) the site location (Column 3), the location of the camera boom (Column 4), the duration of the observation period (Column 5), and the roadway SL (Column 6) listed for each site.

Appendix A provides a map of the greater Twin Cities metropolitan area with icons superimposed on the map indicating the location of the passive and active warning crosswalk sites listed in Table 1. This map illustrates the success of the project in achieving a reasonably broad geographic distribution across the Twin Cities metropolitan area of uncontrolled crosswalk sites for data collection purposes.

Sites listed in Table 2, and shown on the map in Appendix A, were selected based on consultation with the Mn/DOT Technical Advisory Panel (TAP) for the project (Acknowledgments). Across all sites, roadway SLs ranged from 20 to 35 miles per hour (mph). Observation periods ranged from 50 to 110 min in duration during daylight hours, and were scheduled at times of day with anticipated crosswalk pedestrian traffic. Adverse weather conditions (wind, rain, cold and snow at the end of November) constrained the total number of sites observed---one particularly problematic period was September, 2007, when successive storms resulting in record rainfall prevented any observation sessions from being carried out for the entire month.

Usable data were retrieved from 18 of the sites listed in Table 2---hereafter, these sites are termed ‘acceptable data sites.’ Excessive noise in the camera image data arising from wind-related movement of the camera boom, or site calibration problems, compromised processing of camera data collected from the remaining six sites.

Appendix B contains photographs of each of the 18 acceptable data sites. The sequential order of uncontrolled crosswalk site photographs presented in Appendix B is identical to the sequential order of sites listed in Table 3 (below), namely passive warning followed by active warning followed by pedestrian-actuated warning sites.

Table 3 summarizes the number of interactions observed across the 18 acceptable data sites, categorized by type of interaction (vehicle-crosswalk and vehicle-pedestrian, last two columns of table), and by type of uncontrolled crosswalk warning at each site (9 passive, 3 continuously active, and 6 pedestrian-actuated, middle column of table). The low number of 3 sites observed with continuously active crosswalk warnings reflects the relatively low number of uncontrolled crosswalk sites in the Twin Cities metropolitan area with this type of warning. Comparing

Table 2. Descriptions of uncontrolled crosswalk sites observed.

<b>Date</b>	<b>Type of Crosswalk</b>	<b>Crosswalk Location</b>	<b>Location of Camera Boom</b>	<b>Duration of Observation Period (min)</b>	<b>Roadway Speed Limit at Site (mph)</b>
6/29/07	Active. Continuous. Mid-block.	UM East Bank Campus. SE corner of Cooke Hall. East-west crosswalk across Union St. from sidewalk south of Civil Engineering to sidewalk south of Cooke Hall.	Parking lot behind SW corner of Cooke Hall.	50	20
7/5/07	Active. Continuous. Mid-block.	South Minneapolis. 28 <sup>th</sup> Avenue S. east of Lake Hiawatha. East-west crosswalk south of East 46 <sup>th</sup> St., for trail from Lake Hiawatha park area across 28 <sup>th</sup> Avenue S. to trail along Minnehaha Creek.	West side of 28 <sup>th</sup> Avenue South, in park area just west of sidewalk, between East 46 <sup>th</sup> Street and crosswalk.	90	30
7/6/07	Active. Pedestrian-actuated. Mid-block.	South Minneapolis. East Minnehaha Parkway north of Lake Nokomis. North-south crosswalk west of intersection of Woodlawn Blvd. and East Minnehaha Parkway, for trail across the Parkway from Lake Nokomis park area to Lake Hiawatha park area.	North of East Minnehaha Parkway, in park area between Woodlawn Blvd. to east and crosswalk to west, and just west of where East Minnehaha Parkway splits into separate one-way lanes.	110	30
7/9/07	Active. Pedestrian-actuated. Mid-block.	St. Paul, near downtown. Rice Street south of Aurora Ave. East-west crosswalk across Rice Street from State Transportation Building to east and Sears parking lot to west.	Sears parking lot, west of crosswalk.	110	35
7/13/07	Active. Continuous. Mid-block to south, unsignalized intersection to north.	St. Paul, just north of State Capitol. University Ave. at Capitol Blvd. North-south crosswalk across University Ave., from sidewalk north of Capitol across University Ave. to sidewalk on north side of University Ave. next to Capitol Blvd.	Roof of parking ramp located in NE quadrant of the intersection of University Ave. and Capitol Blvd.	90	35
7/16/07	Two passive. Two unsignalized intersections.	Roseville, near eastern boundary. Two north-south crosswalks across County Rd. C, from city park to south and sidewalk on north side of County Rd. C. One crosswalk is near the intersection of County Rd. C and Farrington St, the other near the intersection of County Road C and Galtier St.	South side of County Road C in park area, across from intersection of County Road C and Matilda Street, with Galtier crosswalk to east, and Farrington crosswalk to west.	70	30

<b>Date</b>	<b>Type of Crosswalk</b>	<b>Crosswalk Location</b>	<b>Location of Camera Boom</b>	<b>Duration (min)</b>	<b>Roadway SL (mph)</b>
7/20/07	Passive. Mid-block.	St. Paul, near north boundary of city. Arlington Ave. between railroad bridge to west and intersection with Trout Brook Circle to east. North-south crosswalk connecting rural park trail to north with parking lot for U.S. post office to south.	North side of Arlington Ave., in rural park grassy area directly across from intersection of Arlington Ave. with Trout Brook Circle.	90	30
7/25/07	Passive. Mid-block	St. Paul, near north boundary of city. Arlington Ave. between Mississippi St. and I35E to west and Westminster Ave. to east. Gateway State Trail north-south crossing, midway between Mississippi St. and Westminster Ave.	South side of Arlington Ave. next to curb, a few feet west of intersection of Arlington and Westminster	90	30
7/27/07	Passive. Mid-block.	UM East Bank Campus. East-west crosswalk across Union Street SE, connecting west end of Scholars' Walk (on east side of street) and sidewalk (on west side of street) directly in front of driveway separating the Electrical Engineering and Computer Science Bldg. (to the south) and Akerman Hall (to the north).	Top level of Washington Ave. parking ramp, in NW corner.	90	20
8/3/07	Passive. Mid-block	UM East Bank Campus. North-south crosswalk across Pillsbury Drive, just south of Armory building, about 100 ft east of intersection of Church Street SE and Pillsbury Drive	SE quadrant of intersection of Pillsbury Drive and Church Street SE, on sidewalk.	75	20
8/6/07	Passive. Mid-block.	Inver Grove Heights. East-west crosswalk across Blaine Ave., between east and west Gerten's parking lots, with roadway markings, roadway shoulder signs, and pedestrian routing barriers on curbside medians.	West side of Blaine Ave. next to roadway curb, about 500 ft north of crosswalk, just south of entrance to Gerten's rock yard.	110	35
8/8/07	Active. Pedestrian-actuated. Mid-block.	Woodbury. East-west crosswalk across Interlachen Parkway, connecting combined pedestrian/bicycle park trails on both side of road, about 250 yards north of Duckwood Trail.	North entrance to parking lot for park patrons, on west side of road, about 160 ft north of crosswalk.	80	30

<b>Date</b>	<b>Type of Crosswalk</b>	<b>Crosswalk Location</b>	<b>Location of Camera Boom</b>	<b>Duration (min)</b>	<b>Roadway SL (mph)</b>
8/10/07	Active. Pedestrian-actuated. Mid-block.	Minneapolis. North-south crosswalk across West River Parkway, about 100 yards east of Stone Arch Bridge, connecting sidewalk on north side of old, preserved grain mill (to south of West River Parkway) with scenic byway on north side of West River Parkway.	Off road north of West River Prkwy. and east of crosswalk, about halfway between Mississippi River spillway (downriver from Stone Arch Bridge) and West River Prkwy.	75	30
8/13/07	Active. Pedestrian-actuated. Unsignalized intersection.	Roseville. East-west crosswalk across Lexington Ave., between Roseville Central Park to east, connecting to sidewalk on north side of Oakcrest Ave. to west (2 blocks south of County Road C).	In Roseville Central Park parking lot north of crosswalk, almost directly across from intersection of Lexington Ave. and Oakcrest Ave.	90	30
8/15/07	Passive. Mid-block to south (County Road B), unsignalized intersection on north (Grotto St.)	Roseville. North-south crosswalk across County Road B, connecting sidewalk on east side of Grotto St. to north, and a house lawn fronting County Road B to south (no sidewalk on south side of County Road B in this block), just west of entrance/exit driveway for Parkview Center School parking lot.	East side of entrance/exit driveway for Parkview Center School parking lot, about 20 feet in from driveway entrance to County Road B.	78	30
8/17/07	Active. Pedestrian-actuated. Mid-block.	Roseville. East-west crosswalk across Dale Street, midway between County Road C to north, and intersection of Sextant Ave. (to west) and Transit Ave. (to east) with Dale Street, connecting Roseville Central Park on both sides of Dale Street.	East side of Dale Street, about 300 ft south of crosswalk, on grass next to trees about 20 ft off street, and about 400 ft from Wildlife Rehabilitation Center.	84	30
8/24/07	Passive. Mid-block. 'Unapproved' crosswalk, with no roadway markings or warning signs.	St. Louis Park. East-west crosswalk across Beltline Blvd., connecting Kenilworth Bicycle Trail crossing road, just north of Canadian Pacific Railroad tracks (the trail parallels the tracks), with Park Glen Road just to south, and Highway 7 just to north.	About 50 ft south of railroad tracks in grassy area just west of Beltline Blvd., near Federal Express building.	50	30

Table 2 (continued)

<b>Date</b>	<b>Type of Crosswalk</b>	<b>Crosswalk Location</b>	<b>Location of Camera Boom</b>	<b>Duration (min)</b>	<b>Roadway SL (mph)</b>
10/3/07	Active. Pedestrian-actuated. Mid-block.	Minneapolis. SW-NE bearing Greenway Trail crossing across Minnehaha Ave., south of 26 <sup>th</sup> Street East and just west of 26 <sup>th</sup> Avenue South. The Greenway Trail crosses Hiawatha Ave. just west of this site.	In a parking lot about 75-90 feet SW of crosswalk, just west of Minnehaha Ave., and about 100 feet north of old rail bed.	60	30
10/22/07	Active. Mid-block. Continuously flashing beacon suspended over roadway.	Coon Rapids. North-south crosswalk across Northdale Blvd. NW, connecting Coon Rapids High School parking lot to south with parking lot, tennis courts, and playing fields to north.	In parking lot about 20 ft west of crosswalk, in NE quadrant of intersection of Wren St. NW & Northdale Blvd. NW.	110	20
10/24/07	Passive. Mid-block across NE-bound two lanes of 4-lane boulevard with median strip.	St. Paul. SE-NW bearing crosswalk across NE-bound two lanes of John Ireland Blvd. This crosswalk connects State of Minnesota Transportation Building to north with parking lot for state employees to south.	At parking meter on NE-bound two lanes of John Ireland Blvd., about 100 ft east of crosswalk, next to sidewalk bearing SE at right angles to roadway. Only NE-bound traffic viewed.	95	25
10/29/07	Passive. Mid-block.	Minneapolis. North-south crosswalk across Godfrey Parkway in Minnehaha Park, connecting wooded area to north with east-west bike trail and access to park to south. Crosswalk is just east of entrance to parking lot to south, and one short block to the east of a roundabout connecting Godfrey Parkway with Minnehaha Ave.	In the parking lot on the south side of Godfrey Prkwy and , west of crosswalk, in the RV parking spaces parallel to the road, about 20 ft from south edge of road and about 25 ft from entrance to parking lot.	90	30
11/12/07	Passive. Unsignalized intersection.	Woodbury. North-south crosswalk across Lake Road, immediately adjacent to intersection of Wyndham Way with Lake Road.	NW quadrant of intersection of Lake Road and Wyndham Way, about 50 ft kitty-corner across intersection from crosswalk.	50	30
11/26/07	Passive. Mid-block.	Richfield. North-south crosswalk across West 77 <sup>th</sup> Street, connecting neighborhood (behind a sound wall) to the north, and an east-west sidewalk and a parking lot near a Best Buy store to south.	On sidewalk on south side of West 77 <sup>th</sup> Street, behind Best Buy store, viewing west.	70	35

Table 3. Number of vehicle-crosswalk and vehicle-pedestrian interactions recorded from acceptable data sites.

Site	Observation Date	Crosswalk Warning Type	Number of Vehicle-Crosswalk Interactions Observed	Number of Vehicle-Pedestrian Interactions Observed
1	7/16/2007	Passive	222	7
2	7/20/2007	Passive	480	3
3	7/25/2007	Passive	315	28
4	8/3/2007	Passive	191	21
5	8/6/2007	Passive	323	5
6	8/15/2007	Passive	535	1
7	10/24/2007	Passive	357	16
8	10/29/2007	Passive	216	24
9	11/12/2007	Passive	310	21
10	7/5/2007	Continuously Active	752	126
11	7/13/2007	Continuously Active	355	32
12	10/22/2007	Continuously Active	632	34
13	7/6/2007	Pedestrian-Actuated	576	126
14	7/9/2007	Pedestrian-Actuated	336	74
15	8/8/2007	Pedestrian-Actuated	152	6
16	8/10/2007	Pedestrian-Actuated	210	48
17	8/13/2007	Pedestrian-Actuated	503	18
18	8/17/2007	Pedestrian-Actuated	840	6

Table 4. Statistical summary of interactions observed for 18 acceptable data sites.

Type of Interaction	Statistic	Type of Crosswalk Warning			Aggregate Totals
		Passive	Continuously Active	Pedestrian-Actuated	
	Number of Sites	9	3	6	18
	% Total Sites	50.0	16.7	33.3	100
<b>Vehicle-Crosswalk</b>	<b>Total</b>	2949	1739	2617	7305
	% Total	40.4	23.8	35.8	100
	Range	191-535	355-752	152-840	152-840
	Average Interactions per Site	327.7	579.7	436.2	405.8
<b>Vehicle-Pedestrian</b>	<b>Total</b>	126	192	278	596
	% Total	21.1	32.2	46.6	100
	Range	1-28	32-126	6-126	1-126
	Average Interactions per Site	14.0	64.0	46.3	33.1

entries in Table 2 with those in Table 3 shows that observations on 6/29/07, on 7/16/07 for the County Road C and Farrington crosswalk, on 7/27/07, on 8/24/07, on 10/3/07, and on 11/26/07 did not result in collection of usable data.

As summarized in Table 4 for the 18 acceptable data sites, a total of 7,305 vehicle-crosswalk, and 596 vehicle-pedestrian, interactions were observed. The three crosswalk warning types---passive, continuously active, and pedestrian-actuated---accounted respectively for 40.4, 23.8 and 35.8 percent of the vehicle-crosswalk interactions, and 21.1, 32.2 and 46.6 percent of the vehicle-pedestrian interactions, observed. Across all 18 sites, the numbers of vehicle-crosswalk interactions observed ranged from a minimum of 152 to a maximum of 840 interactions; for vehicle-pedestrian interactions, the comparable range was 1 to 126 interactions.

### **2.2.2. Independent Measures**

Independent measures are the type of uncontrolled crosswalk warning (passive, continuously active, or pedestrian-actuated), and the presence or absence of a pedestrian at a crosswalk.

### **2.2.3. Dependent Measures**

Dependent measures are the average velocities and deceleration/acceleration (decel/accel) values of vehicles approaching the crosswalk for each vehicle-crosswalk and vehicle-pedestrian interaction, averaged as follows: (1) across a total vehicle traversal distance of 82.0 ft (25 m) (from  $82.0 \pm 8.2$  ft ( $25 \pm 2.5$  m) to  $16.4 \pm 8.2$  ft ( $5 \pm 2.5$  m) adjacent to crosswalk); and (2) at 82.0 ft (25 m), 65.6 ft (20 m), 49.2 ft (15 m), 32.8 ft (10 m), and 16.4 ft (5 m) from the crosswalk, averaged across  $\pm 8.2$  ft ( $\pm 2.5$  m) bin intervals at each of these distances.

### **2.2.4. Null Hypotheses**

The null hypotheses for the study are that no main or interaction effects of warning type or pedestrian presence/absence on the dependent measures will be observed.

## **2.3. Methods Employed to Analyze Vehicle Interactions with Uncontrolled Crosswalks**

As noted in Section 2.1, collection of data pertaining to the vehicle-crosswalk and vehicle-pedestrian interactions summarized in Table 4 relied upon two methodological innovations, related to traffic monitoring system and automated image processing software platforms developed expressly for the project. These innovations are described in the following sections.

### **2.3.1. Traffic Monitoring Platform**

A modular, portable camera boom system was designed and applied as a low-cost alternative to using a bucket truck for traffic monitoring purposes. As illustrated by the schematic in Figure 1, the system comprises a pole nested 8 ft aluminum tube elements, mounted at the base to a trailer hitch of an observation vehicle, and stabilized with supporting rods affixed to the luggage rack of the vehicle, creating a sturdy, stable platform for mounting the cameras. The boom height typically ranged from 24 to 32 ft, depending upon the site.

The camera mount itself, at the terminus of the top tube, comprises a base supporting two pan-and-tilt camera mounts, to which are affixed two analog cameras equipped with wide angle lenses. The pan-and-tilt mounts enabled control of the 2-D orientation of each camera. Cable connections allowed: (1) ground-based remote control of the pan-and-tilt of each camera; and (2) a video feed from each camera through an A-D converter to a ground-based laptop computer. Electronics are powered by a 12-volt car battery.

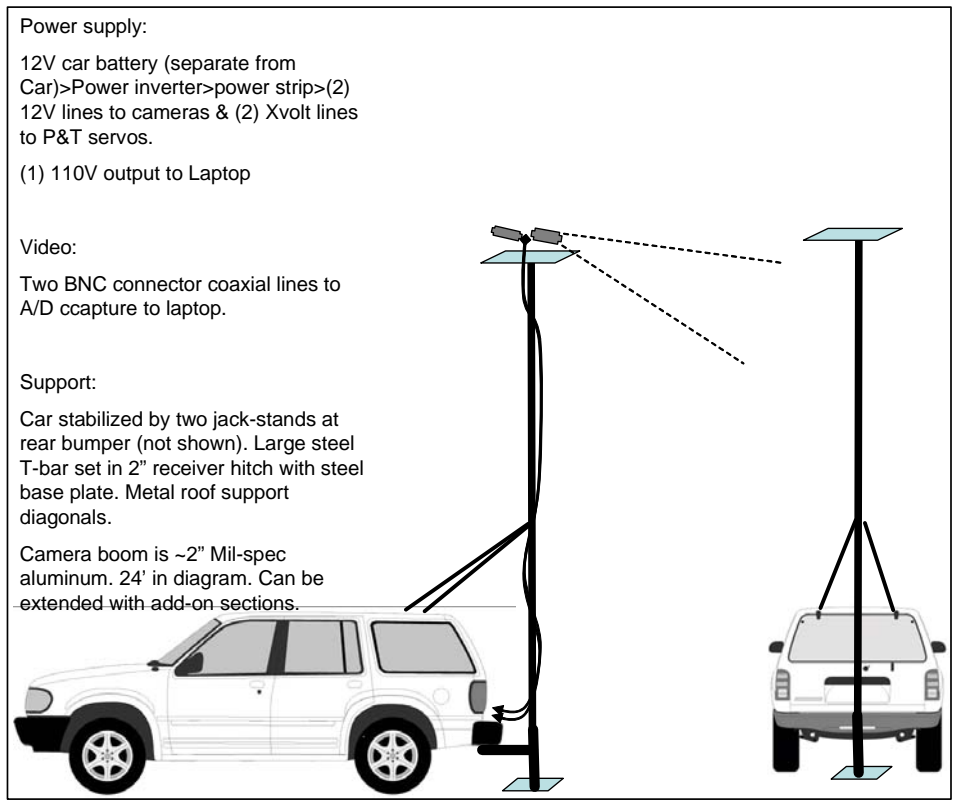
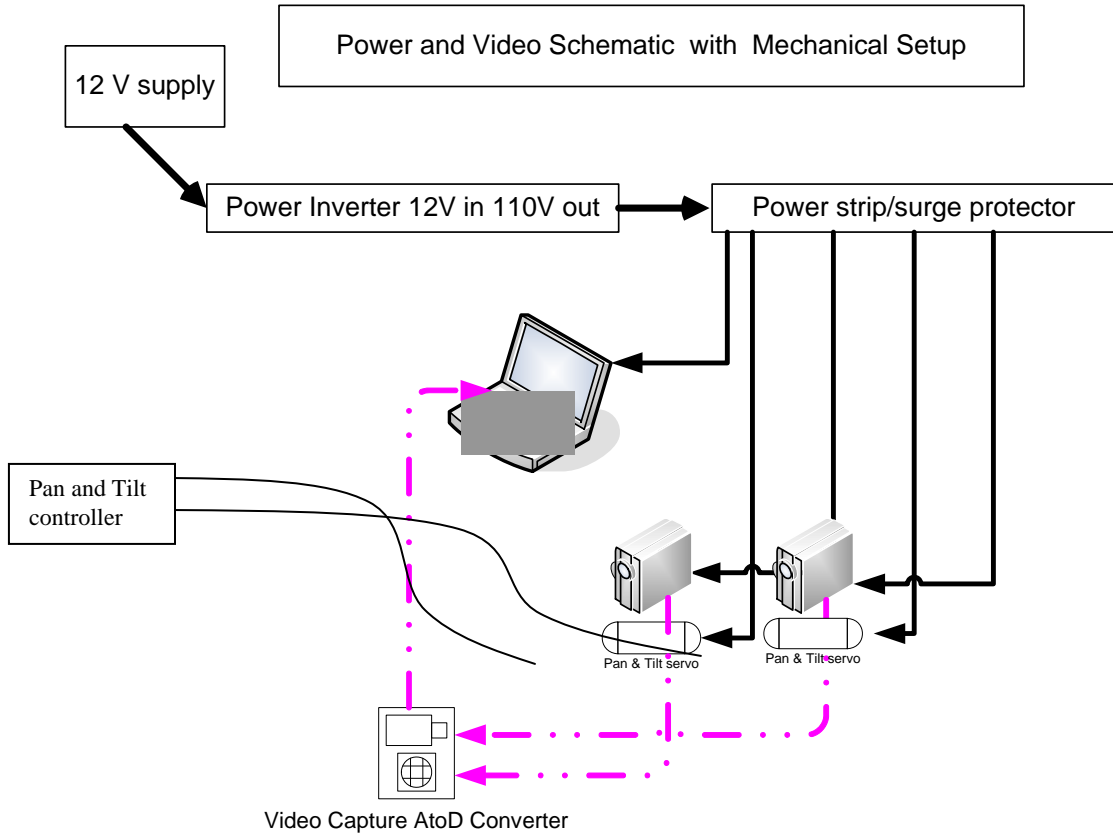

Figure 1. Schematic of camera boom and traffic monitoring system.



Figure 2. Photograph of camera boom erected at an observation site.

Figure 2 is a photograph of the actual camera boom system erected at an observation site. Figure 3 is a close-up of the two cameras affixed to the pan-and-tilt mounts at the apex of the boom. Appendix C lists the components comprising the system.

With this system, camera orientation could be controlled from the ground after the boom had been erected, and simultaneous recording of vehicle traffic approaching the crosswalk from both roadway directions was possible. The system can be readily assembled and disassembled, and system components are transportable in the vehicle. The system thus allows flexible and convenient scheduling of crosswalk observation and data collection sessions.

### **2.3.2. Data Reduction and Analysis**

The second project innovation is a C++ computer vision software platform [39], created as part of a broader computer vision program at the UM Artificial Intelligence Robotics and Vision Laboratory (AIRVL) [40], that automatically computes distances, velocities, and decel/accel values of moving vehicles, as well as vehicle and pedestrian counts, across successively recorded 30 frame/sec camera images. The system comprises the following subroutines: image stabilization, background segmentation, region processing and blob extraction, blob association, and position and velocity tracking. For each vehicle-crosswalk and vehicle-pedestrian interaction observed, computed data are written to a spreadsheet and dependent measures



Figure 3. Close-up of cameras affixed to pan-and-tilt mounts at apex of boom.

calculated using MatLab. Appendix D provides a schematic flow chart and a description of this computer vision software platform.

## **2.4. Experimental Protocol**

The experimental protocol consists of three major sets of procedures, related to selecting and surveying uncontrolled crosswalk sites for observation, locating and erecting the camera boom and configuring the traffic monitoring system, and configuring the video capture software. These procedures are summarized in the following subsections.

### **2.4.1 Selecting and Surveying Uncontrolled Crosswalk Sites**

Observations of vehicle-crosswalk and vehicle-pedestrian interactions at different uncontrolled crosswalk sites were preceded by a series of procedures directed at selecting and surveying these sites, as follows.

1. Potential sites for observation were identified by the research team, in consultation with the Mn/DOT TAP for the project, and with other members of the surface transportation community in the Twin Cities metropolitan area.
2. Satellite images of a potential site were examined for any potential features (i.e., vegetation, overhead power lines, lack of adjacent parking for observation vehicle) that might compromise camera imaging of the site.

3. If a given site was deemed suitable for observation, a preliminary examination of the site was carried out with the intent of close-up evaluation. The evaluation was directed at making judgments of likely pedestrian traffic at the site, and of collecting site layout photographs.
4. A provisional schedule of observation dates and times for collecting data at sites selected for observation was drawn up, based on results of Steps 1-3.

#### **2.4.2. Locating and Erecting the Camera Boom, and Configuring the Traffic Monitoring System**

Procedures for locating and erecting the camera boom and configuring the traffic monitoring system comprise the following steps (refer to Fig. 1 for illustrations of the boom components cited in some of the steps below). These steps require two research team members working in concert.

1. For some sites, prior approval from the municipality or from other parties responsible for oversight of the site was required before site observation could be carried out. As needed, this approval was secured prior to the observation session scheduled for these sites.
2. At the scheduled observation date and time for a given site, the observation vehicle is driven to the site, and conditions at the site once again are evaluated. If the site is deemed unacceptable for observation because of unforeseen factors, any nearby sites (previously selected or not) are inspected for data collection at that time, or for future reference.
3. Once a site is deemed acceptable for observation, the area is scouted for the best location for the observation vehicle. Line-of-site conditions and potential traffic hazards are the priorities in making this selection.
4. The observation vehicle then is parked and oriented for the best camera view of the site. Other factors that dictated vehicle positioning were level ground, and a safe distance from potential hazards (power lines, etc.). There usually must be a clear arc in which to raise the boom pole, but if necessary it can be assembled vertically by sections.
5. The rear bumper of the observation vehicle then is stabilized with jacks. The boom hitch assembly (which forms the base of the boom, see Fig. 1) is laid near the trailer hitch on the vehicle, but on its side (see step 8), with the boom insert section on the ground and the boom hitch section vertical.
6. The boom sections are assembled on the ground (usually). The camera mount then is mounted into the end of the mast and rested on a foam mat (Fig. 3 shows this mount in its erected position).
7. The cable snake (i.e., video feed, pan-and-tilt control, and power line cables) is wrapped around the boom at least 1.5 times to keep down wind resistance.
8. The boom is inserted into the hitch assembly on the ground. Diagonal luggage rack supports are mounted to the boom only at this point, at about 10 ft up the boom.
9. Parallel to Steps 5-8, the power inverter is plugged into the 12V outlet on the observation vehicle with accompanying power strip. The Laptop is plugged into the power inverter.
10. The hitch assembly then is raised with one research team member using a short 4 ft section of the boom in the receiver hitch tube (square) as a fulcrum. This person uses the assembly foot plate to stabilize the boom as it is raised. The second research team member raises the boom from its apex (camera) end, and walks the boom up. In this step, the fulcrum setup is not necessary, but it does help in erecting the boom.
11. Once the boom is vertical, both research team members keep the assembly stable, slide it into the receiver hitch, and pin it into place. The foot of the boom may require an adjustment in

height, depending on the slope of the terrain. There are 3 pin settings for this. For maximum stability (usually not required), the bumper jacks can be raised slightly, the foot lengthened, and the bumper jacks then lowered.

12. Diagonal supports are then mounted to the roof rack on the observation vehicle.
13. Orientations of the camera heads then are adjusted using the remote pan-and-tilt control.
14. Video images from the cameras are acquired and digitized, at a rate of 30 frames/sec, using a 4-channel Universal Serial Bus (USB) Digital Video Recorder (DVR) (Appendix C). Digitized data are streamed into computer memory via the laptop's USB port. The video capture software used to process these video data then is configured (Section 2.4.3 below).
15. Once the image capture software is configured, the cameras are adjusted relative to lighting conditions. This adjustment includes determining and setting the camera zoom setting.
16. Site calibration of the visual field viewed by the cameras is carried out, in one of three ways: (1) observing roadway markings with known dimensions (such as lane markings); (2) measuring the dimensions of one or roadway features evident in the images prior to commencement of data collection; or (3) placing a calibration stick with known dimensions in the visual field (Appendix E, Fig. E-1). Calibration of the visual field is necessary for achieving accurate automated computation of vehicle velocities and decel/accel values, relative to background features, across successive video image frames.
16. Recording of video images from the cameras then is initiated. To reduce glare on the laptop monitor under sunny conditions, an umbrella is used (barely visible to the right of and behind the observation vehicle in Fig. 2) to shield the laptop.
17. Observations of traffic/pedestrian behaviors and weather conditions are recorded on a site observation recording form (Appendix F). Interview notes with selected pedestrians also are recorded.
18. Prior to or during data acquisition, digital photos are made of salient features at the site. These include photographs of notable vehicle-crosswalk, vehicle-pedestrian, and pedestrian crosswalk interactions that may occur during the observation period, as well as photographs of: (1) views of the crosswalk from the observation vehicle; (2) views of the observation vehicle from the crosswalk; (3) lateral views of the crosswalk; and (4) views of the crosswalk from the two roadway directions. Appendix B contains examples of these photographs for each site.
19. Disassembly of the camera boom and traffic monitoring system basically is the reverse of Steps 5-14.

A series of photographs illustrating preparation and erection of the camera boom system, as described in Steps 5-14 above, is contained in Appendix E. Appendix F contains an example of the observation recording form that was used to record salient conditions and features observed during each site observation session (Step 16 above) (the form in Appendix F pertains to the observation session for Site 14 (Table 3 above)).

### **2.4.3. Configuring the Video Capture Software Platform**

The video capture software is proprietary and issued by the manufacturer of the USB DVR. It consists of four screens pertaining to four video input channels it is capable of supporting. Once the video input is provided to at least one of the four channels, the images show up in the appropriate screen on the laptop monitor (an error message is displayed on the laptop monitor if video input from the cameras is not connected).

With these images on the laptop monitor, the exposure, contrast, and color can be adjusted for that particular video channel independently, without disturbing the other channels. Further, the pan-and-tilt platform can be adjusted to orient the cameras appropriately, using the remote controller, by looking at the video display on the laptop monitor. Once these settings are finalized, the cameras are ready for recording.

There are several video recording modes such as motion sensed recording, scheduled recording mode, manual recording, etc. For this project scheduled recording was selected, which records video input from the cameras using a given schedule, whenever recording is enabled. It is possible to set up different recording schedules for different camera inputs. Using scheduled recording helps to synchronize video input from the two different cameras, such that they begin and end recording at the same time. This is done by selecting identical schedules for the two cameras. Once recording is completed, the software is closed and the USB DVR is stopped.

## **2.5. Statistical Analysis**

Multivariate analysis of variance (ANOVA) for the main and interactive effects of type of warning and pedestrian presence/absence, on average vehicle velocities and decel/accel values separately, was carried out using Pillai's trace to test for statistical significance [41]. This was followed by *post hoc* analysis of statistically significant effects using the Bonferroni procedure (IBID). To compare averages for vehicle velocities and decel/accel values between vehicle-crosswalk and vehicle-pedestrian interactions at each site, paired t-test analysis was used (both types of interactions were recorded during the same session at each site). High and marginal levels of statistical significance are set, respectively, at  $p < .05$ , and  $p < .10$ . Error bars in figures are 95% confidence intervals.

## **2.6. Limitations**

Major limitations of the study may be summarized as follows.

- The study observed uncontrolled crosswalks using a cross-sectional design in an ecological context. Levels of vehicle or pedestrian traffic across different sites were variable. Unbalanced counts of crosswalk warning types, and of vehicle-crosswalk and vehicle pedestrian interactions by warning type, consequently were obtained.
- The low number of active warning sites (3) reflects the paucity of this type of uncontrolled crosswalk warning in the Twin Cities area.
- Roadway SLs varied (20-35 mph) between sites. Crosswalks on roadways with higher SLs were not evaluated.
- Observations were made during daylight hours only. Nighttime conditions possibly would be associated with different results.
- Uncontrolled crosswalks with roadway marking warnings only (i.e., no yellow warning signs on roadway shoulder) were not observed.
- Observations of crosswalks equipped with pedestrian-actuated warnings did not document whether or not pedestrians using the crosswalks actually actuated the warning.
- With data collected across a five-month period, a seasonal effect on the data also is possible.
- The observations did not document the degree to which use of the crosswalks may have been accessible by pedestrians with disabilities.

The nature and extent of these limitations necessarily limits the generalizability of the results obtained, as well as the statistical rigor of the data analysis.

## Chapter 3 Results

Results for vehicle-crosswalk and vehicle-pedestrian interactions at uncontrolled crosswalk sites with different warning types are categorized in sections below in relation to: (1) overall average velocities and decel/accel values, averaged between 25±2.5 m and 2.5±2.5 m (82.0±8.2 ft and 16.4±8.2 ft) adjacent to the crosswalk; (2) average velocities and decel/accel values at successive 5 m (16.4 ft) distances (25, 20, 15, 10, and 5 m, or 82.0, 65.6, 49.2, 32.8, and 16.4 ft) from the crosswalk, averaged across ±2.5 m (±8.2 ft) bin intervals at each of these distances; and (3) frequency distributions of average velocities and decel/accel values for vehicles observed at 25, 20, 15, 10, and 5 m (82.0, 65.6, 49.2, 32.8, and 16.4 ft) from the crosswalk, averaged across ±2.5 m (±8.2 ft) bin intervals at each of these distances.

### 3.1. Overall Average Vehicle Velocities and Decelerations/Accelerations

Multivariate ANOVA for the main effects of warning type and type of interaction on overall average vehicle velocities shows a marginally significant main effect of type of interaction ( $F_{(2,14)}=2.18$ ;  $p=.097$ ). The source of this effect is illustrated in Figure 4, which plots overall average vehicle velocities in mph (averaged from 82.0 ft (25 m) to 16.4 ft (5 m) adjacent to crosswalk) by type of warning (passive; active; pedestrian-actuated), for vehicle-crosswalk (black bars) and vehicle-pedestrian (white bars) interactions. For pedestrian-actuated warning sites, average velocity for vehicle-crosswalk interactions is significantly higher (by paired-t test,  $p=.020$ ) than for vehicle-pedestrian interactions. No such significant difference is observed for sites with either passive or active warnings. Across all sites and interaction types, average overall vehicle velocities as vehicles approached the crosswalk ranged from about 15 to about 22 mph.

*Post hoc* analysis of these ANOVA results reveals no significant differences between warning types in overall average vehicle velocities grouped by type of interaction, as shown in Figure 5 (left histograms – vehicle-crosswalk interactions; right histograms – vehicle-pedestrian interactions).

Multivariate ANOVA for the main effects of warning type and type of interaction on overall average vehicle decel/accel values shows no statistically significant effects. Figure 6 plots overall average vehicle decel values in ft/sec/sec (averaged from 82.0 ft (25 m) to 16.4 ft (5 m) adjacent to crosswalk) by type of warning (passive; active; pedestrian-actuated), for vehicle-crosswalk (black bars) and vehicle-pedestrian (white bars) interactions. Figure 7 plots overall average vehicle decel values grouped by type of interaction (left histograms – vehicle-crosswalk interactions; right histograms – vehicle-pedestrian interactions). Across all sites and interaction types, average overall vehicle decel values as vehicles approached the crosswalk ranged from about -2.3 to about -3.2 ft/sec/ sec.

### 3.2. Average Vehicle Velocities and Decelerations/Accelerations at Different Distances from the Crosswalk

Multivariate ANOVA for the main effects of warning type and type of interaction on average vehicle velocities at different distances from the crosswalk shows significant main effects of both warning type ( $F_{(10,48)}=3.28$ ;  $p=.003$ ) and type of interaction ( $F_{(5,23)}=2.79$ ;  $p=.041$ ). Figures 8 and 9, and Tables 5 and 6, delineate the basis of these effects. Figures 8 and 9 plot average vehicle

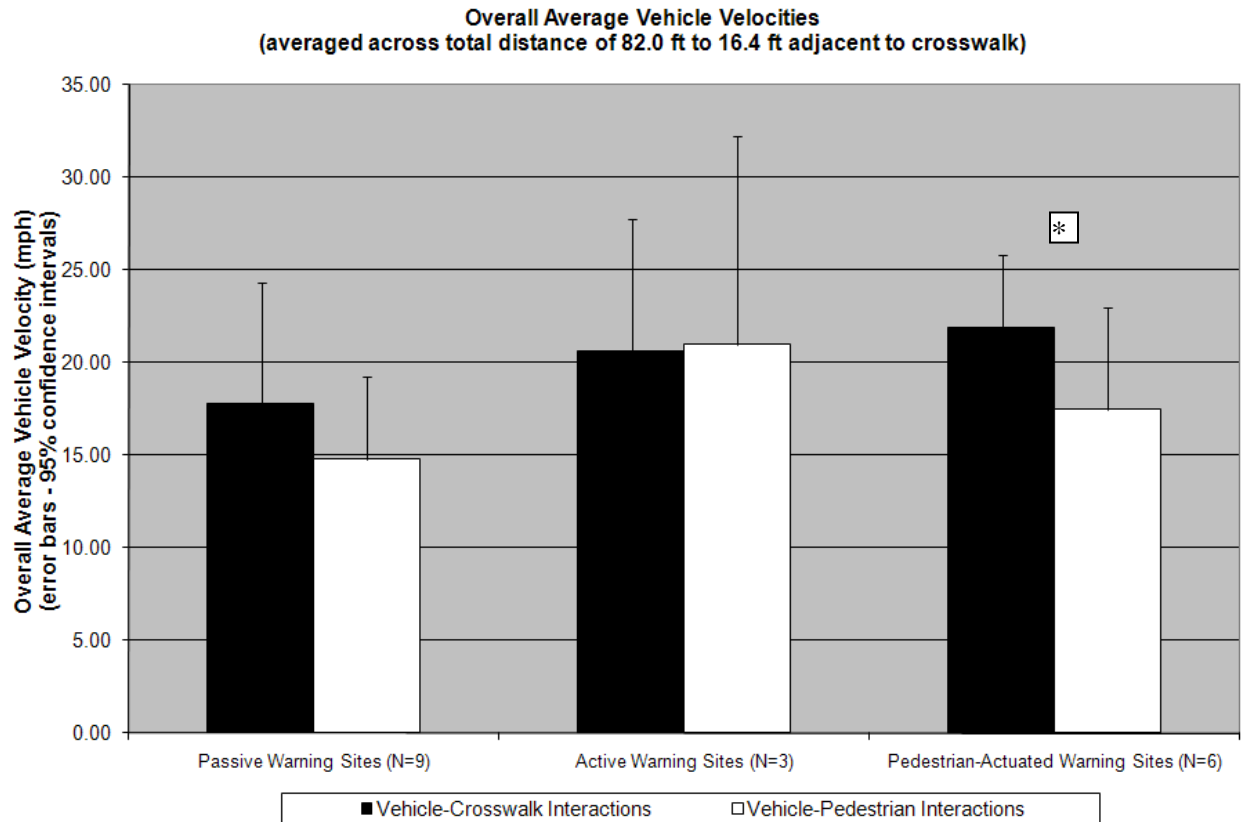

Figure 4. Overall average vehicle velocities (averaged from 82.0 ft to 16.4 ft adjacent to crosswalk) for vehicle-crosswalk (black bars) and vehicle-pedestrian (white bars) interactions, grouped by type of warning (passive; active; pedestrian-actuated) (\*  $p=.020$ ).

velocities at successive 16.4 ft (5 m) distances from the crosswalk, for vehicle-crosswalk (Fig. 8) and vehicle-pedestrian (Fig. 9) interactions respectively. In each figure, average velocities for each of the three types of warning (squares – passive warning sites; diamonds – active warning sites; triangles – pedestrian-actuated warning sites) are plotted. For purposes of visual clarity in both Figures 8 and 9, 95% confidence intervals plotted as error bars are divided by a factor of 5.

For vehicle-crosswalk interactions, Figure 8 shows that average vehicle velocities vary between about 15 and about 25 mph across all successive distances from the crosswalk, for all three warning types. Average vehicle velocities for vehicle-crosswalk interactions: (1) increase steadily from about 17 to just under 25 mph at the closest two distances to the crosswalk for the active warning sites; and (2) decrease from just under 25 to about 20 mph at the closest three distances to the crosswalk for the pedestrian-actuated warning sites. Post-hoc analysis of the ANOVA results shows that there are no significant differences in average vehicle velocities between warning types at any of the crosswalk distances indicated in Figure 8.

For vehicle-pedestrian interactions, Figure 9 shows that average vehicle velocities vary between just over 10 and just over 25 mph across all successive distances from the crosswalk, for all three warning types. Average vehicle velocities for vehicle-pedestrian interactions: (1) are above 25 mph for the two greatest distances from the crosswalk, but are under 15 mph for the two smallest distances from the crosswalk, for the passive warning sites; (2) increase steadily from about 15 to about 25 mph for the three smallest distances from the crosswalk, for the active

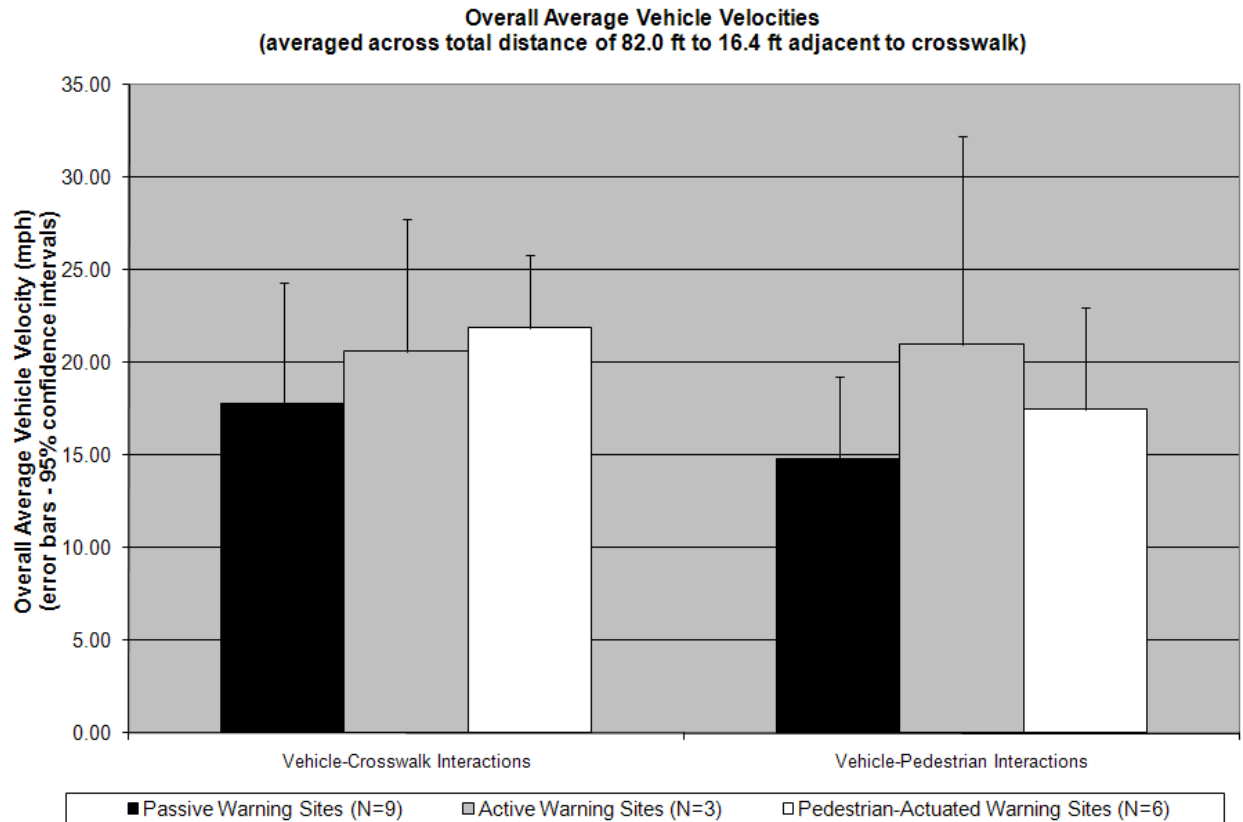

Figure 5. Overall average vehicle velocities for different types of warning (passive; active; and pedestrian-actuated - black, gray, and white bars respectively), grouped by type of interaction (vehicle-crosswalk interactions - left histograms; vehicle-pedestrian interactions - right histograms).

warning sites; and (3) decrease more or less steadily from about 23 to under 15 mph from the largest to the smallest distance from the crosswalk for the pedestrian-actuated warning sites. Post-hoc analysis of the ANOVA results shows that there are no significant differences in average vehicle velocities between warning types at any of the crosswalk distances indicated in Figure 9.

In Table 5, significant differences in average vehicle velocities at successive distances from the crosswalk, between vehicle-crosswalk and vehicle-pedestrian interactions for the three warning types, are indicated with asterisks to indicate marginally significant (\*,  $p < .10$ ) and significant (\*\*,  $p < .05$ ) results. The analysis in Table 5 involves use of a paired t-test to compare average vehicle velocities at each crosswalk distance for vehicle-crosswalk interactions with those for vehicle-pedestrian interactions, for each warning type separately. The only significant effects are for the pedestrian-actuated warning sites. Specifically, results in Table 5 show that for the four distances closest to the crosswalk, average vehicle velocities for vehicle-crosswalk interactions (Fig. 8) are significantly higher than those for vehicle-pedestrian interactions (Fig. 9).

In Table 6, significant differences in average vehicle velocities measured at different distances from the crosswalk, for vehicle-crosswalk and vehicle-pedestrian interactions treated

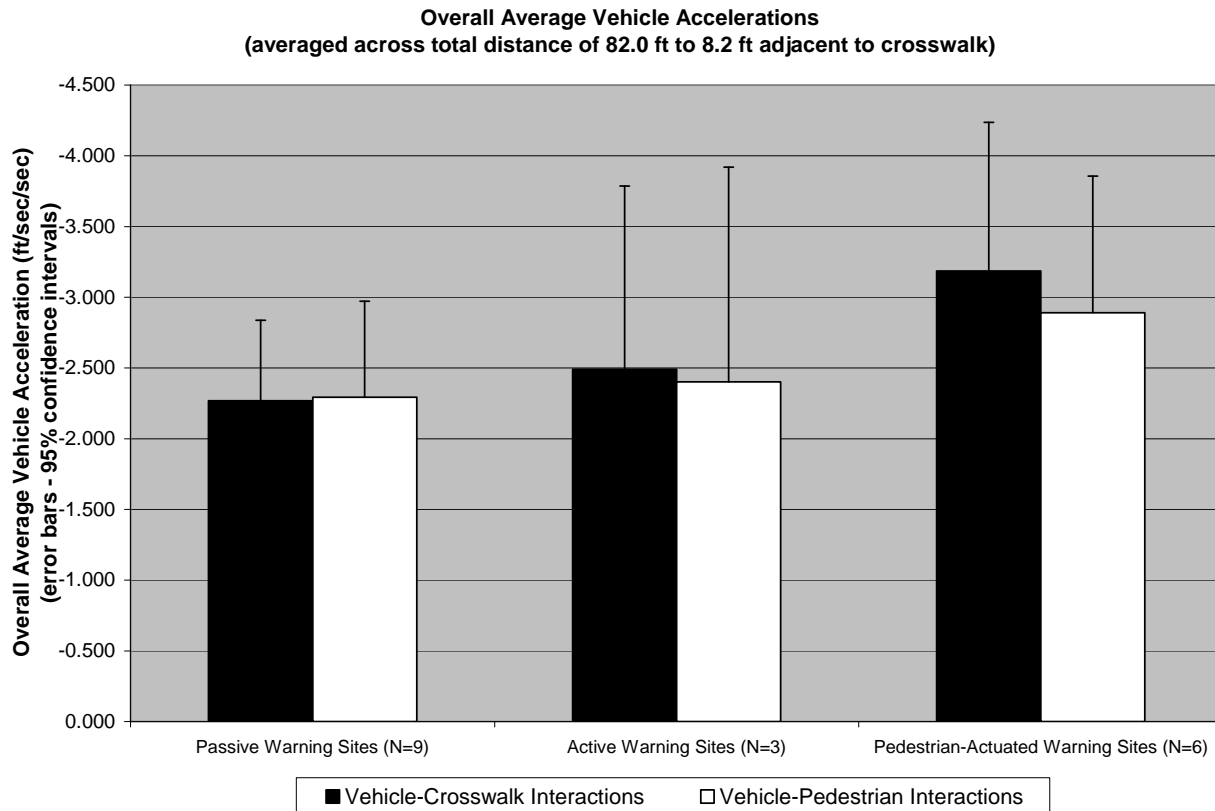

Figure 6. Overall average vehicle decel/accel values (averaged from 82.0 ft to 16.4 ft adjacent to crosswalk) for vehicle-crosswalk (black bars) and vehicle-pedestrian (white bars) interactions, grouped by type of warning (passive; active; pedestrian-actuated)

independently and categorized by warning type, are indicated with asterisks to indicate marginally significant (\*,  $p < .10$ ) and significant (\*\*,  $p < .05$ ) results. The analysis in Table 6 involves use of a paired t-test to compare average vehicle velocities at each crosswalk distance with those for the other crosswalk distances, treating the two types of interactions and each warning type separately.

Results in Table 6 for vehicle-crosswalk interactions show two sets of significant effects: (1) at the pedestrian-actuated warning sites, average vehicle velocities at 16.4 ft from the crosswalk are significantly lower than those at 82.0 ft, 49.2 ft, and 32.8 ft from the crosswalk---as well, the difference in average vehicle velocities between 49.2 ft and 32.8 ft from the crosswalk also is significant; and (2) for both the passive and active warning sites, the differences in average vehicle velocities at 65.6 ft versus 32.8 ft are significant.

Results in Table 6 for vehicle-pedestrian interactions also show two sets of significant effects: (1) at the passive sites, differences in average vehicle velocities for the following pairs of crosswalk distances are significant---82.0 ft versus 32.8 ft, 49.2 ft versus 32.8 ft and 16.4 ft, and 32.8 ft versus 16.4 ft; and (2) at the pedestrian-actuated warning sites, differences in average vehicle velocities are significant for the 82.0 ft crosswalk distance relative to all other crosswalk distances, and as well for the 49.2 ft versus 32.8 ft and 16.4 ft, and the 32.8 ft versus 16.4 ft, distances. The significant effects for both the passive and pedestrian-actuated warning sites

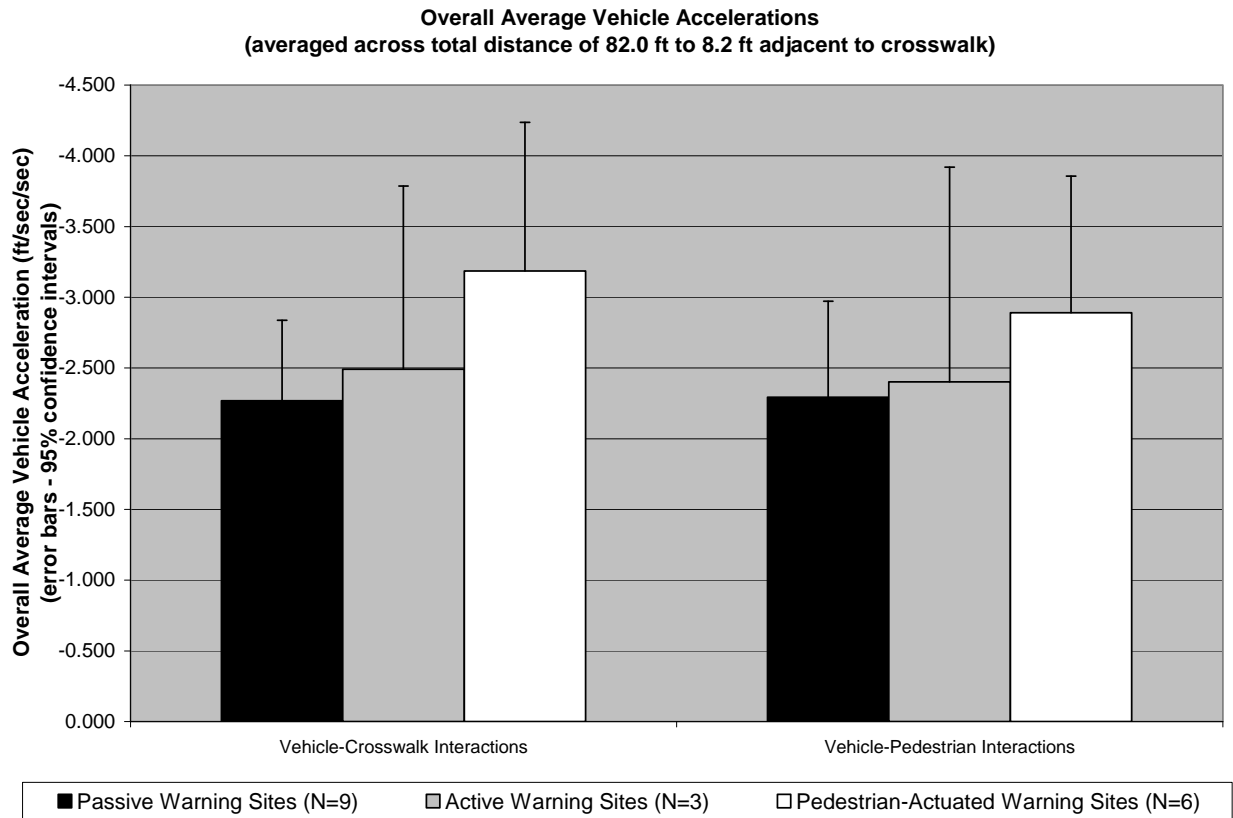

Figure 7. Overall average vehicle decel/accel values for different types of warning (passive; active; and pedestrian-actuated - black, gray, and white bars respectively), grouped by type of interaction (vehicle-crosswalk interactions - left histograms; vehicle-pedestrian interactions - right histograms).

reflect a more or less progressive lowering of average vehicle velocities at these sites going from the largest to the smallest crosswalk distances (Fig. 9).

Multivariate ANOVA for the main effects of warning type and type of interaction on average vehicle decel values at different distances from the crosswalk shows a marginally significant main effect of type of interaction ( $F_{(5,23)}=2.57$ ;  $p=.055$ ), but the main effect of warning type is not statistically significant. Figures 10 and 11, and Tables 7 and 8, delineate the basis of these findings. Figures 10 and 11 plot average vehicle decel values at successive 16.4 ft (5 m) distances from the crosswalk, for vehicle-crosswalk (Fig. 10) and vehicle-pedestrian (Fig. 11) interactions respectively. In each figure, average velocities for each of the three types of warning (squares – passive warning sites; diamonds – active warning sites; triangles – pedestrian-actuated warning sites) are plotted. For purposes of visual clarity in both Figures 10 and 11, 95% confidence intervals plotted as error bars are divided by a factor of 4.

For vehicle-crosswalk interactions, Figure 10 shows that average vehicle decel values vary between about -2.0 and about -3.5 ft/sec/sec across all successive distances from the crosswalk, for all three warning types. The only consistent pattern of change is observed for the pedestrian-actuated warning results, for which average vehicle decel values increase steadily from just over 2.5 ft/sec/sec to just under 3.5 ft/sec/sec between 65.6 and 16.4 ft from the crosswalk. Post-hoc

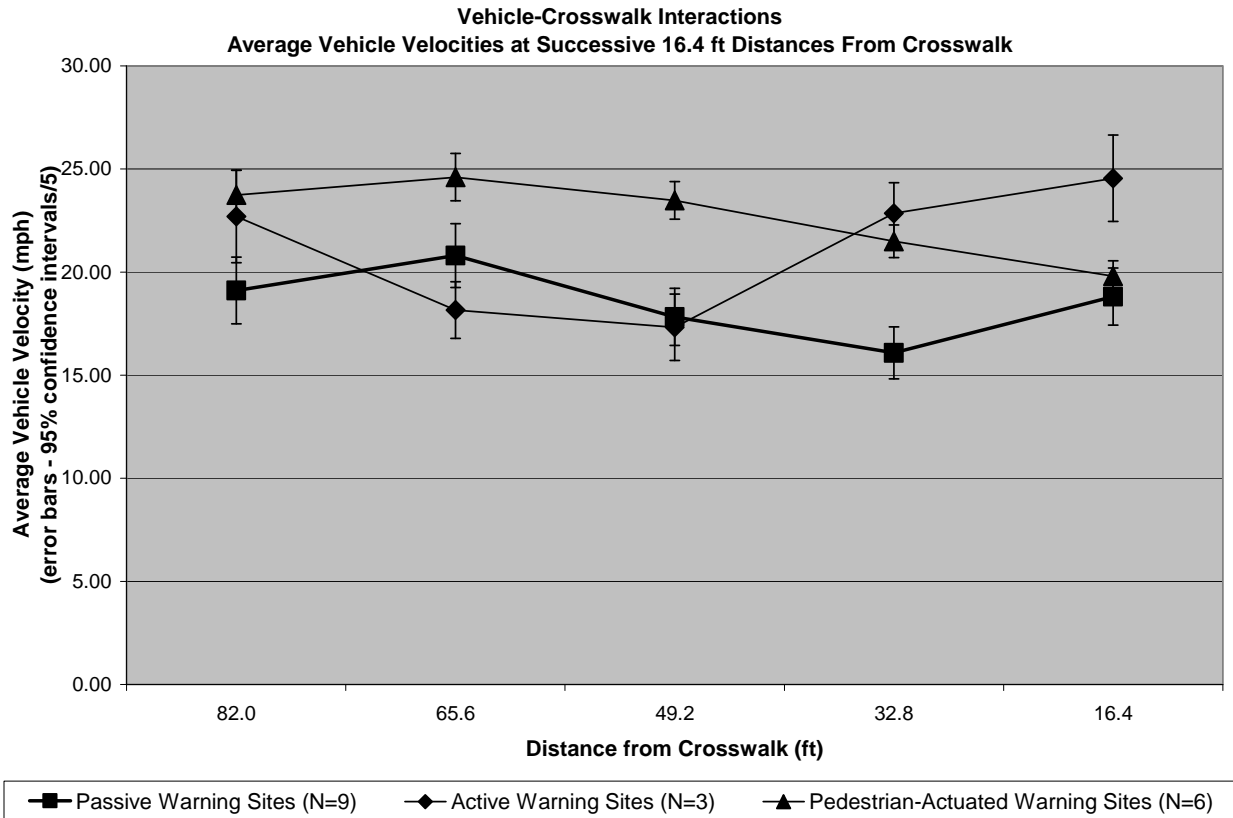

Figure 8. Average vehicle velocities for vehicle-crosswalk interactions at successive 16.4 ft distances from the crosswalk, for passive (squares), active (diamonds), and pedestrian-actuated (triangles) warning sites. To aid visual clarity of the graph, each 95% confidence interval value has been divided by a factor of 5.

Table 5. Significant differences (by paired t-test) in average vehicle velocities at successive distances from the crosswalk between vehicle-crosswalk and vehicle-pedestrian interactions.

Type of Warning	Distance From Crosswalk (ft)				
	82.0	65.6	49.2	32.8	16.4
Passive					
Active					
Pedestrian-Actuated		*	**	**	**

\*p<.10 ; \*\*p<.05

analysis of the ANOVA results shows that there are no significant differences in average vehicle decel values between warning types at any of the crosswalk distances indicated in Figure 10.

For vehicle-pedestrian interactions, Figure 11 shows that average vehicle decel values vary over a broader range (relative to the results for vehicle-crosswalk interactions in Figure 10) between about -1.0 and about -3.5 ft/sec/sec across all successive distances from the crosswalk, for all three warning types. Average vehicle decel values for vehicle-pedestrian interactions: (1) increase steadily from about -3.5 to about -1.5 ft/sec/sec for the four smallest distances from the

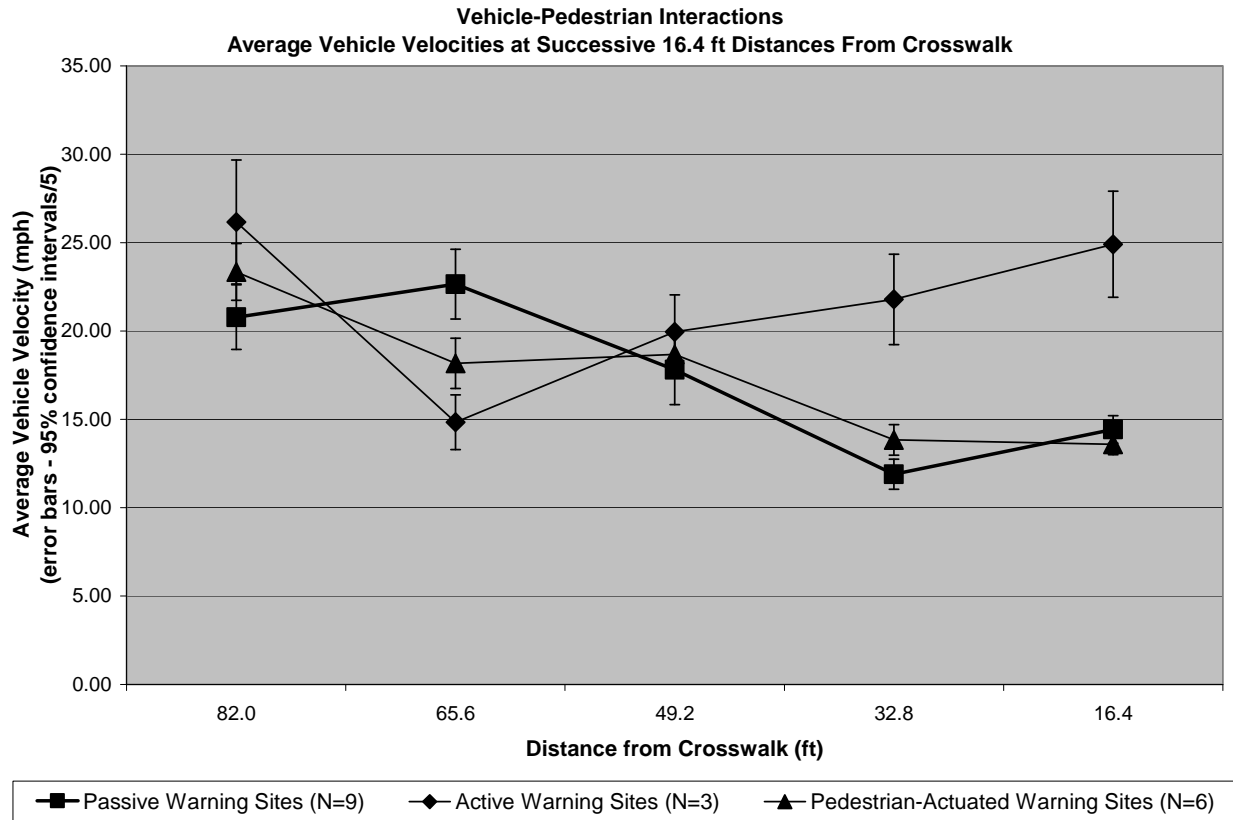

Figure 9. Average vehicle velocities for vehicle-pedestrian interactions at successive 16.4 ft distances from the crosswalk, for passive (squares), active (diamonds), and pedestrian-actuated (triangles) warning sites. To aid visual clarity of the graph, each 95% confidence interval value has been divided by a factor of 5.

Table 6. Significant differences (by paired t-test) in average vehicle velocities measured at different distances from the crosswalk, for vehicle-crosswalk and vehicle-pedestrian interactions.

Crosswalk Distance (ft) Comparison	Type of Interaction and Warning Type					
	Vehicle-Crosswalk			Vehicle-Pedestrian		
	Passive	Active	Pedestrian-Actuated	Passive	Active	Pedestrian-Actuated
82.0 vs 65.6						*
82.0 vs 49.2						**
82.0 vs 32.8				**		*
82.0 vs 16.4			*			**
65.6 vs 49.2				*		
65.6 vs 32.8	*	**		**		
65.6 vs 16.4				*		
49.2 vs 32.8			*			*
49.2 vs 16.4			**			**
32.8 vs 16.4			**			**

\*p<.10 ; \*\*p<.05

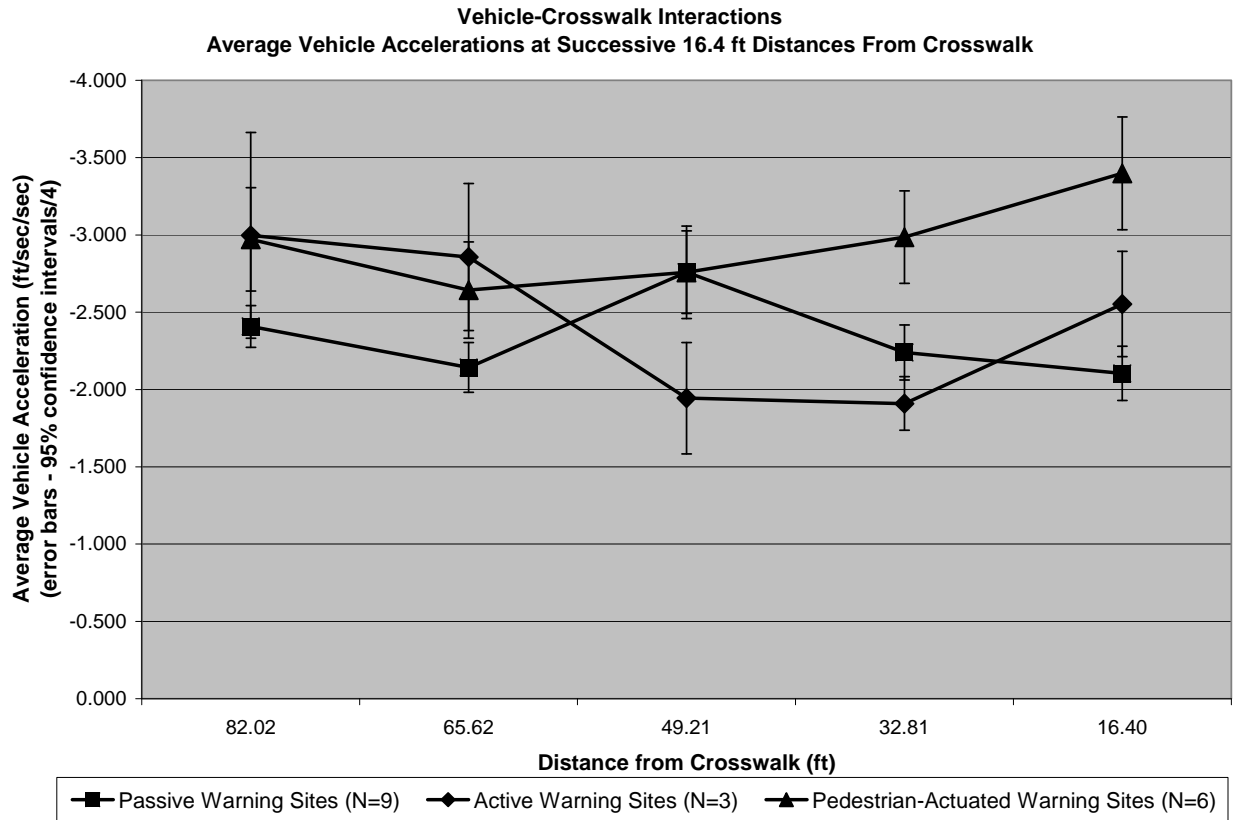

Figure 10. Average vehicle decel values for vehicle-crosswalk interactions at successive 16.4 ft distances from the crosswalk, for passive (squares), active (diamonds), and pedestrian-actuated (triangles) warning sites. To aid visual clarity of the graph, each 95% confidence interval value has been divided by a factor of 4.

Table 7. Significant differences (by paired t-test) in average vehicle decel values at successive distances from the crosswalk between vehicle-crosswalk and vehicle-pedestrian interactions.

Type of Warning	Distance From Crosswalk (ft)				
	82.0	65.6	49.2	32.8	16.4
Passive		*			
Action					
Pedestrian-Actuated					

\*p<.10

crosswalk for the passive warning sites; (2) decrease steadily from about -3.0 to about -1.0 ft/sec/sec for the three smallest distances from the crosswalk for the active warning sites; and (3) increase markedly from about -1.0 to about -3.0 ft/sec/sec for the four smallest distances from the crosswalk for the pedestrian-actuated warning sites. Post-hoc analysis of the ANOVA results shows that there are no significant differences in average vehicle decel values between warning types at any of the crosswalk distances indicated in Figure 11.

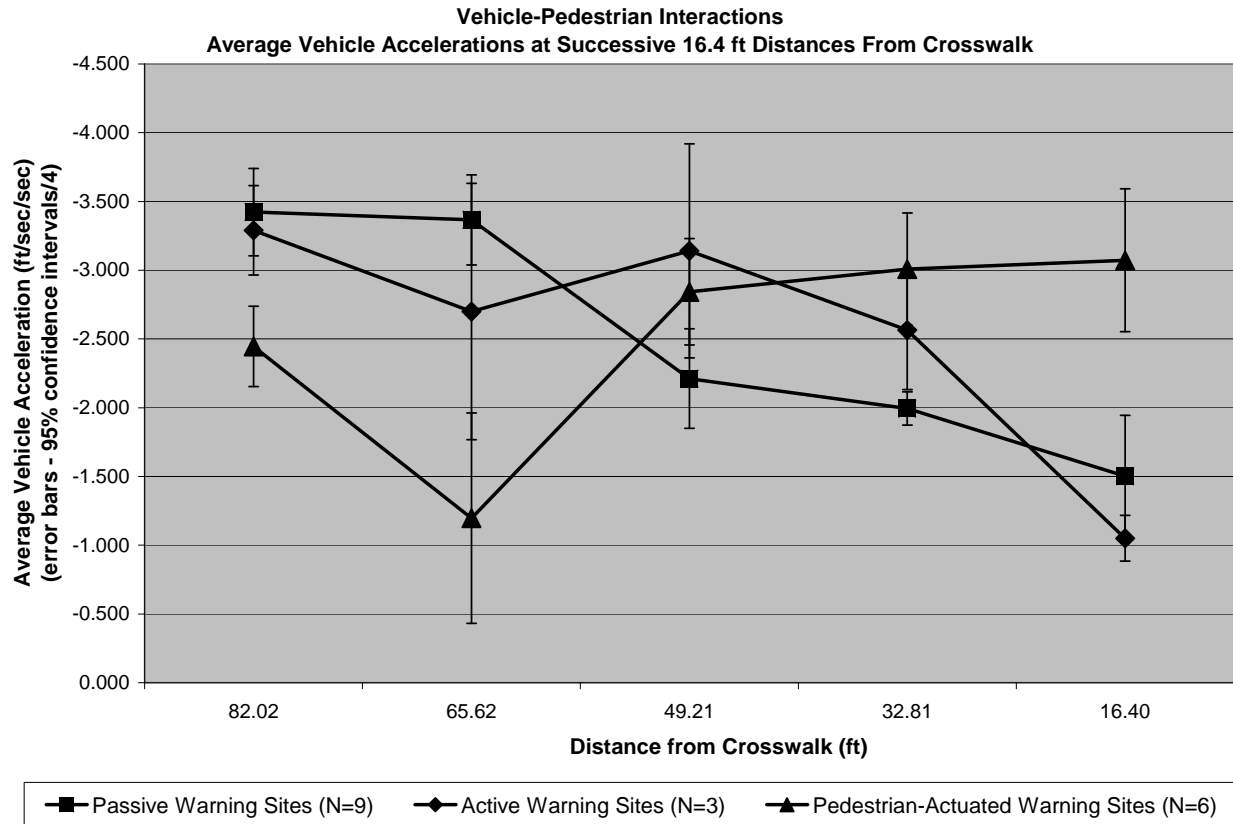

Figure 11. Average vehicle decel values for vehicle-pedestrian interactions at successive 16.4 ft distances from the crosswalk, for passive (squares), active (diamonds), and pedestrian-actuated (triangles) warning sites. To aid visual clarity of the graph, each 95% confidence interval value has been divided by a factor of 4.

Table 8. Significant differences (by paired t-test) in average vehicle decel values measured at different distances from the crosswalk, for vehicle-crosswalk and vehicle-pedestrian interactions.

Crosswalk Distance (ft) Comparison	Type of Interaction and Warning Type					
	Vehicle-Crosswalk			Vehicle-Pedestrian		
	Passive	Active	Pedestrian-Actuated	Passive	Active	Pedestrian-Actuated
82.0 vs 65.6						
82.0 vs 49.2						
82.0 vs 32.8						
82.0 vs 16.4				*	*	
65.6 vs 49.2						
65.6 vs 32.8						
65.6 vs 16.4						
49.2 vs 32.8						
49.2 vs 16.4		*				
32.8 vs 16.4						

\*p<.10

In Table 7, significant differences in average vehicle decel values at successive distances from the crosswalk, between vehicle-crosswalk and vehicle-pedestrian interactions for the three warning types, are indicated. The analysis in Table 7 involves use of a paired t-test to compare average vehicle velocities at each crosswalk distance for vehicle-crosswalk interactions with those for vehicle-pedestrian interactions, for each warning type separately. There is only one marginally significant effect. For passive warning sites at 65.6 ft from the crosswalk, the average vehicle decel value for vehicle-crosswalk interactions (Fig. 10) is marginally significantly lower than that for vehicle-pedestrian interactions (Fig. 11).

In Table 8, significant differences in average vehicle decel values measured at different distances from the crosswalk, for vehicle-crosswalk and vehicle-pedestrian interactions treated independently and categorized by warning type, are indicated. The analysis in Table 8 involves use of a paired t-test to compare average vehicle decel values at each crosswalk distance with those for the other crosswalk distances, treating the two types of interactions and each warning type separately.

Results in Table 8 for vehicle-crosswalk and vehicle-interactions show only three marginally significant effects: (1) at the active warning sites for vehicle-crosswalk interactions (Fig. 10), the average vehicle decel value at 49.2 ft from the crosswalk is marginally significantly lower than that at 16.4 ft from the crosswalk; and (2) at the passive and active warning sites for vehicle-pedestrian interactions (Fig. 11), both differences in average vehicle decel values at 82.0 ft versus 16.4 ft are marginally significant.

### **3.3. Frequency Distributions of Average Counts for Vehicle Velocities and Decelerations/ Accelerations at Different Distances from the Crosswalk**

This section presents results pertaining to how the frequency distribution of average vehicle velocities and decel/accel values is influenced by the type of vehicle-crosswalk interaction (i.e., pedestrian absent or present), by the type of crosswalk warning, and by the distance of the vehicle from the crosswalk. The computer vision software platform used for automated analysis of vehicle dynamics (Section 2.3.2), enabled calculation of successive values of vehicle velocity and decel/accel as the vehicle approached the crosswalk, for each interaction of a vehicle with a crosswalk. The term *frequency distribution* refers to the number of counts of vehicle velocities or decel/accel values for different magnitude ranges of these measures. Categorical averages for these intervals then are computed, based on type of vehicle-crosswalk interaction, type of crosswalk warning, and distance from crosswalk.

Results in this section represent two types of analyses. Figures 13-24 present histograms of average counts of vehicle velocities and decel/accel values for different magnitude ranges, grouped across five different vehicle-crosswalk distances, for each of the two types of vehicle-crosswalk interaction (pedestrian absent or present) and the three types of crosswalk warnings. Appendix G presents a series of 20 figures featuring histograms of average counts of vehicle velocities and decel/accel values for different magnitude ranges, in which results for the three types of crosswalk warning and one vehicle-crosswalk distance are plotted in each figure.

To clarify the results employed in generating the figures cited above, Table 9 provides an example of one set of data, for the particular case of the frequency distributions of average velocities at 82.0 ft (25 m) from the crosswalk for vehicle-crosswalk and vehicle-pedestrian interactions at sites featuring each of the three types of crosswalk warnings. Ten different velocity ranges are specified in the second and third rows of the table, in mph and kilometers per hour (kph) respectively, namely 0-6.2 mph (0-10 kph), 6.2-12.4 mph (10-20 kph), 12.4-18.6 mph

Table 9. Average counts of velocities observed ( $\pm 1$  SD) at 82.0 ft (25 m) from the crosswalk, in ten different velocity ranges, for vehicle-crosswalk and vehicle-pedestrian interactions at sites with three different types of warnings.

		Average Counts of Velocities Observed in Different mph & kph Velocity Ranges Indicated, at 82.0 ft (25 m) from Crosswalk										
		mph	0-6.2	6.1-12.4	12.4-18.6	18.6-24.8	24.8-31.1	31.1-37.3	37.3-43.5	43.5-49.7	49.7-55.9	55.9-62.1
Type of Interaction	Type of Warning	kph	0-10	10-20	20-30	30-40	40-50	50-60	60-70	70-80	80-90	90-100
Vehicle-Crosswalk	Passive (N=9)		115.6 $\pm$ 132.3	38.8 $\pm$ 32.8	42.8 $\pm$ 36.6	25.7 $\pm$ 20.1	43.8 $\pm$ 46.3	54.0 $\pm$ 64.4	14.4 $\pm$ 18.1	15.6 $\pm$ 22.5	16.6 $\pm$ 25.0	10.3 $\pm$ 19.7
Vehicle-Crosswalk	Active (N=3)		18.0 $\pm$ 20.1	161.3 $\pm$ 238.7	155.7 $\pm$ 201.3	48.0 $\pm$ 34.7	152.7 $\pm$ 134.5	98.7 $\pm$ 105.3	63.3 $\pm$ 82.6	4.3 $\pm$ 1.5	4.3 $\pm$ 5.1	2.3 $\pm$ 0
Vehicle-Crosswalk	Pedestrian-Actuated (N=6)		10.3 $\pm$ 11.5	20.7 $\pm$ 18.2	68.7 $\pm$ 89.0	35.3 $\pm$ 25.7	128.5 $\pm$ 132.5	130.7 $\pm$ 234.9	29.5 $\pm$ 54.5	25.2 $\pm$ 55.8	1.7 $\pm$ 0	1.2 $\pm$ 0
Vehicle-Pedestrian	Passive (N=9)		2.8 $\pm$ 6.2	3.1 $\pm$ 6.3	1.9 $\pm$ 3.5	0.7 $\pm$ 0.7	2.6 $\pm$ 3.8	1.3 $\pm$ 2.2	0 $\pm$ 0	0.2 $\pm$ 0	0.1 $\pm$ 0	0 $\pm$ 0
Vehicle-Pedestrian	Active (N=3)		2.3 $\pm$ 2.1	71.3 $\pm$ 121.8	3.7 $\pm$ 3.2	16.3 $\pm$ 24.0	9.0 $\pm$ 8.2	18.0 $\pm$ 17.5	6.0 $\pm$ 6.9	1.7 $\pm$ 0	1.0 $\pm$ 1.0	0.3 $\pm$ 0.5
Vehicle-Pedestrian	Pedestrian-Actuated (N=6)		9.5 $\pm$ 18.2	14.8 $\pm$ 22.5	4.2 $\pm$ 5.0	10.5 $\pm$ 17.5	20.5 $\pm$ 44.4	20.0 $\pm$ 43.7	0.8 $\pm$ 1.0	0.3 $\pm$ 0.5	0.3 $\pm$ 0	0.2 $\pm$ 0

(20-30 kph), 18.6-24.8 mph (30-40 kph), 24.8-31.1 mph (40-50 kph), 31.1-37.3 mph (50-60 kph), 37.3-43.5 mph (60-70 kph), 43.5-49.7 mph (70-80 kph), 49.7-55.9 mph (80-90 kph), and 55.9-62.1 mph (90-100 kph).

For each velocity range and each interaction, the computer vision software platform (Section 2.3.2) computed the number of vehicles (the ‘count’) exhibiting velocities falling within each of these ten specified velocity ranges. These values then were grouped across all vehicle-crosswalk and vehicle-pedestrian interactions observed at 82.0 ft for the nine passive, three active and six pedestrian-actuated warning sites, to yield the average counts listed in the last six rows and ten columns of Table 9. Rows 4-6 in the table contain average counts, within each of the ten specified velocity ranges, for vehicle-crosswalk interactions at passive, active, and pedestrian-actuated warning sites respectively; rows 5-9 in the table contain average counts, within each of the ten specified velocity ranges, for vehicle-pedestrian interactions at passive, active, and pedestrian-actuated warning sites respectively. The error intervals specified in Table 9 for each average velocity count are  $\pm 1$  standard deviation (SD).

Figure 12 represents a graphical depiction of the data in Table 9. Plotted in the figure are average counts (specified on the ordinate) of velocities observed at 82.0 ft (25 m) from the crosswalk, in ten different velocity ranges, for vehicle-crosswalk (first 10

sets of histograms) and vehicle-pedestrian (second 10 sets of histograms) interactions (velocity ranges specified on abscissa). Each of the 20 sets of histograms contains average counts for passive (dark grey bars, N=9), active (very light gray bars, N=3), and pedestrian-

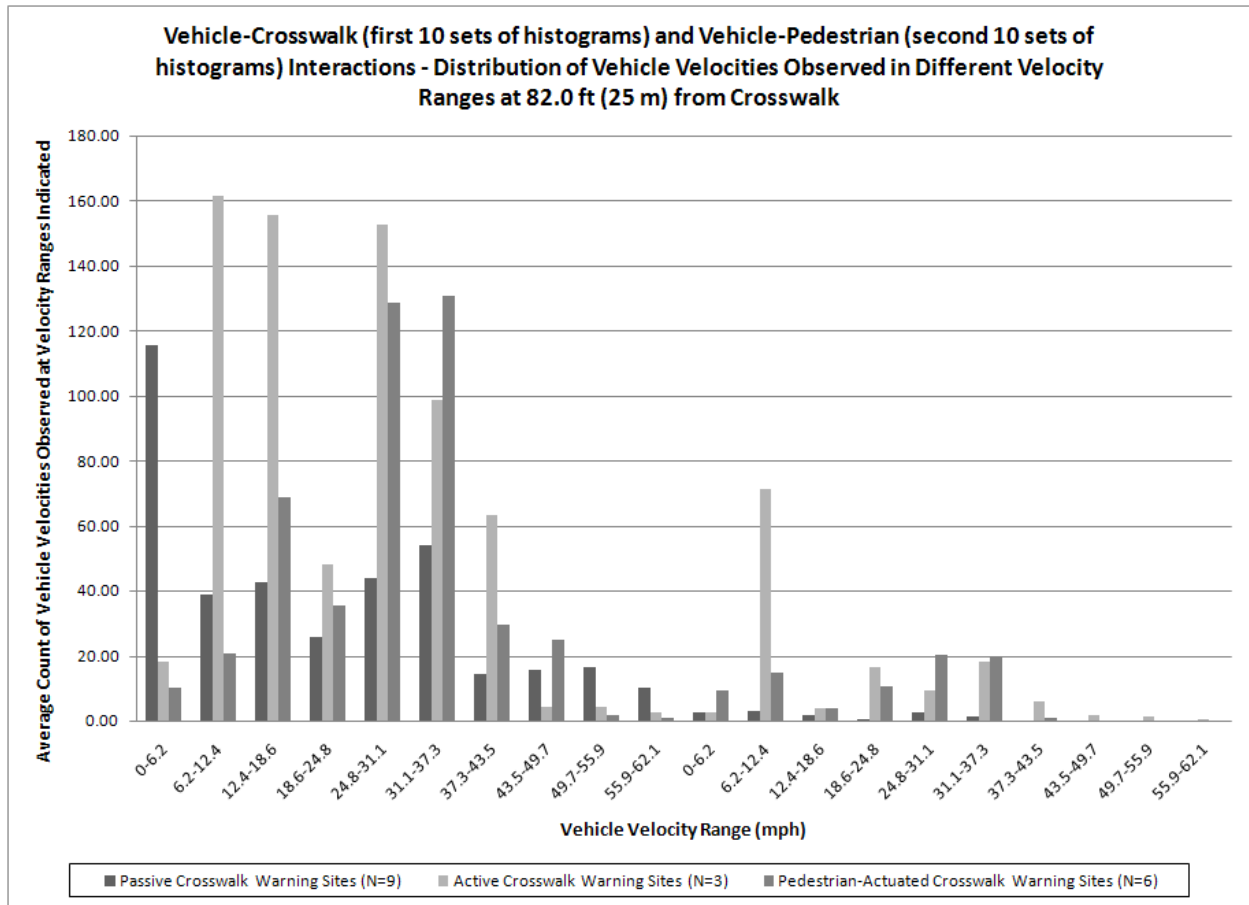

Figure 12. Graphical depiction of data in Table 9. Average counts of velocities observed at 82.0 ft (25 m) from the crosswalk, in ten different velocity ranges, for vehicle-crosswalk (first 10 sets of histograms) and vehicle-pedestrian (second 10 sets of histograms) interactions, at sites with three different types of warnings.

actuated (gray bars, N=6) crosswalk warning sites. Standard deviations for these averages are not plotted in Figure 12.

Results listed in Table 9 and plotted in Figure 12 illustrate some important features of the frequency distribution of average velocity counts that are generally applicable to all sets of such results. First, regardless of type of crosswalk warning, there is no indication of any sort of smoothly increasing or decreasing trend in counts of average velocities across the different velocity ranges. Second, there is a high variance for most average counts---for example, as shown in Table 9, almost three-fourths of the average counts entered in the table have SD values equal to or greater than the corresponding values of the averages. Finally, the magnitudes of average velocity counts for vehicle-crosswalk interactions (such as the leftmost set of 10 histograms in Fig. 12) are substantially higher than those for vehicle-pedestrian interactions (such as the rightmost set of 10 histograms in Figure 12), at corresponding velocity ranges. This latter pattern is explained by the fact that a substantially higher number of vehicle-crosswalk interactions were observed, relative to the number of vehicle-pedestrian interactions observed (Table 3).

The illustrations in Table 9 and Figure 12 of a sample set of data for frequency distributions of average velocity counts in different velocity ranges sets the stage for an analytical summary of

all frequency distribution results, for both average velocity and average decel/accel counts,

Table 10. Levels of significance observed, based on univariate ANOVA of main and interactive effects of type of interaction, type of warning, distance from crosswalk, and velocity or decel/accel range, on average velocity and decel/accel counts.

Main Effect	Interaction Effect	Average Velocity Counts*	Average Decel/Accel Counts*
Type of Interaction (Interaction)		** ( $F_{(1,1,16)}=1.75$ ; $p=.002$ )	** ( $F_{(1,10,21)}=15.43$ ; $p=.003$ )
Type of Warning (Warning)		NS	NS
Distance from Crosswalk (Distance)		NS	NS
Velocity or Decel/Accel Range (Range)		NS	NS
	Interaction x Warning	NS	NS
	Interaction x Distance	** ( $F_{(4,11,58)}=3.56$ ; $p=.04$ )	** ( $F_{(4,6,19)}=5.98$ ; $p=.026$ )
	Warning x Distance	NS	NS
	Interaction x Warning x Distance	NS	** ( $F_{(8,64)}=2.84$ ; $p=.009$ )
	Interaction x Range	** ( $F_{(9,21,38)}=3.81$ ; $p=.005$ )	** ( $F_{(8,10,89)}=21.74$ ; $p<.000$ )
	Warning x Range	NS	NS
	Interaction x Warning x Range	** ( $F_{(18,72)}=4.19$ ; $p<.000$ )	** ( $F_{(16,64)}=2.24$ ; $p=.012$ )
	Distance x Range	NS	NS
	Interaction x Distance x Range	NS	NS
	Warning x Distance x Range	NS	** ( $F_{(64,64)}=1.62$ ; $p=.029$ )
	Interaction x Warning x Distance x Range	NS	NS

\*NS = Not Significant ( $p>.05$ ); \*\* $p<.05$

across different combinations of type of interaction, type of warning, and distance from crosswalk. The first stage of this analysis was a univariate ANOVA for main and interactive effects of four sets of independent measures---type of interaction (vehicle-crosswalk vs vehicle-pedestrian), type of warning (passive, active and pedestrian-actuated warning sites), distance from crosswalk (82.0 ft (25 m), 65.6 ft (20 m), 49.2 ft (15 m), 32.8 ft (10 m), and 16.4 ft (5 m), and ten velocity ranges or nine decel/accel ranges---on average velocity or decel/accel counts observed. The 10 velocity ranges evaluated are itemized above. The nine decel/accel ranges evaluated are as follows: -19.7 to -16.4 ft/sec<sup>2</sup> (-6 to -5 m/ sec<sup>2</sup>), -16.4 to -13.1 ft/ sec<sup>2</sup> (-5 to -4 m/ sec<sup>2</sup>), -13.1 to -9.8 ft/ sec<sup>2</sup> (-4 to -3 m/ sec<sup>2</sup>), -9.8 to -6.6 ft/ sec<sup>2</sup> (-3 to -2 m/ sec<sup>2</sup>), -6.6 to -3.3 ft/ sec<sup>2</sup> (-2 to -1 m/ sec<sup>2</sup>), -3.3 to 0 ft/ sec<sup>2</sup> (-1 to 0 m/ sec<sup>2</sup>), 0 to +3.3 ft/ sec<sup>2</sup> (0 to +1 m/ sec<sup>2</sup>), +3.3 to +6.6 ft/ sec<sup>2</sup> (+1 to +2 m/ sec<sup>2</sup>), and +6.6 to +9.8 ft/ sec<sup>2</sup> (+2 to +3 m/ sec<sup>2</sup>).

Two univariate ANOVAs were carried out, one for a complete set of average velocity counts, the second for a complete set of average decel/accel counts, across all combinations of independent measures. Results of these analyses are in Table 10.

Results in Table 10 show that, with one exception, the only significant main or interactive ANOVA effects on average velocity or decel/accel counts observed are those in which type of interaction is included as one of the independent measures. This finding is unremarkable, given that the average number of observed interactions, and therefore the average number of observed counts, is so much lower for vehicle-pedestrian relative to vehicle-crosswalk interactions (Table 3). The exception is the significant interaction effect of the warning x distance x range on average decel/accel counts.

Figures 13-24 below, and the 20 figures in Appendix G, extend the ANOVA results in Table 10 with plots that profile the frequency distributions of counts of average velocities and decel/accel values under different conditions. Figures in Appendix G are divided into two sets. Figures G-1 through G-10 plot average velocity counts (on the ordinate) for each of ten velocity ranges (on the abscissa), with each of the ten sets of histograms in each figure comparing results for passive (dark gray bars), active (very light gray bars), and pedestrian-actuated (gray bars) crosswalk warning sites. These ten figures comprise five sets of two figures, each set pertaining to average velocity counts observed for one of five different distances from the crosswalk, with results for vehicle-crosswalk interactions plotted as the first figure in each set, followed by results for vehicle-pedestrian interactions plotted as the second figure in each set. Thus, frequency distributions for average velocity counts, for vehicle-crosswalk and vehicle-pedestrian interactions respectively, are plotted in---Figures G-1 and G-2 for 82.0 ft (25 m), Figures G-3 and G-4 for 65.6 ft (20 m), Figures G-5 and G-6 for 49.2 ft (15 m), Figures G-7 and G-8 for 32.8 ft (10 m), and Figures G-9 and G-10 for 16.4 ft (5 m)---from the crosswalk. Note that data plotted in Figure 12 represent a combination of the data plotted in Figures G-1 and G-2.

Figures G-11 through G-20 plot average decel/accel counts, with the same conditions and sequential organization of figures, as described in the preceding paragraph for average velocity counts.

Results for the average velocity counts plotted in Figures G-1 through G-10 show that the preponderance of vehicle velocities observed fall between 0 and 43.5 mph, with relatively few vehicles observed exceeding the latter speed, for all crosswalk warning and type of interaction conditions. As might be expected from the ANOVA results in Table 10, showing lack of statistical significance for a main effect of warning condition, there is no discernibly consistent relationship in average velocity counts among crosswalk warning types across the different velocity ranges, regardless of type of interaction and distance from crosswalk.

However, for the seven lowest velocity ranges, one somewhat consistent pattern is evident. Specifically, average counts for active crosswalk warning sites, for both types of interaction, are often higher than those for passive and pedestrian-actuated warning sites. Thus, for the ten sets of seven histograms at the seven lowest velocity ranges in Figures G-1 through G-10, average velocity counts for active crosswalk warning sites are higher than those for the remaining two warning conditions for 51, or 73 percent, of the 70 cases. This consistent pattern presumably accounts for the statistically significant effect of interaction x warning x range observed (Table 10)

Results for average decel/accel counts in Figures G-11 through G-20 show that, regardless of type of interaction and warning type, the highest average decel/accel counts are observed for the three slowest decel/accel ranges, namely -6.6 to -3.3, -3.3 to 0, and 0 to + 3.3 ft/sec<sup>2</sup>. In a pattern

comparable to that observed for average velocity counts, average decel/accel counts for active crosswalk warning sites are higher than those for the remaining two warning types, at these three

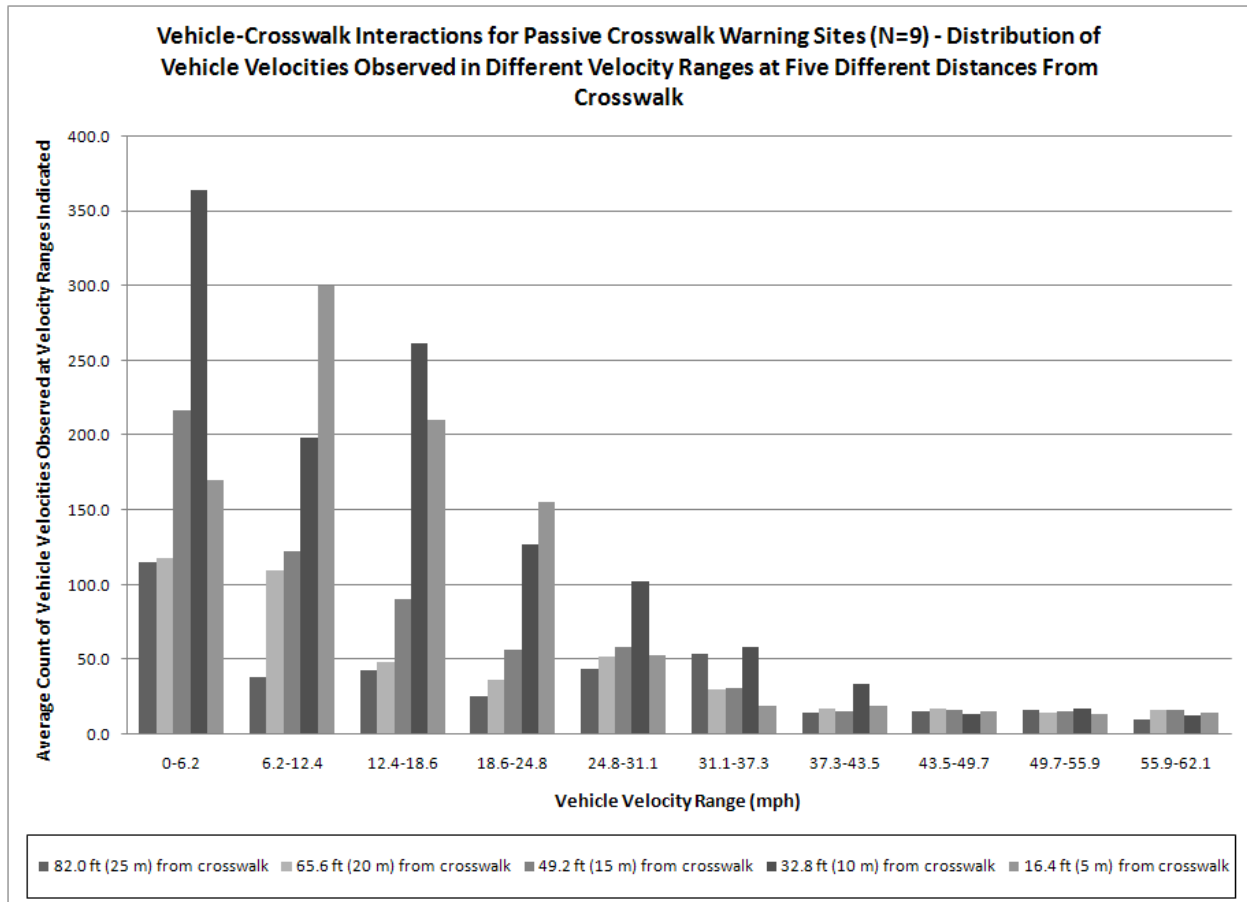

Figure 13. Distribution of average counts for vehicle velocities observed in ten different velocity ranges at five different distances from the crosswalk, for vehicle-crosswalk interactions at passive crosswalk warning sites.

decel/accel ranges, in 24, or 80 percent, of the 30 cases. Furthermore in 19, or 63 percent, of the same 30 cases, average decel/accel counts for pedestrian-actuated warning sites are higher than those for passive warning sites. These patterns presumably account for the statistically significant effects observed for interaction x warning x distance, interaction x warning x range, and warning x distance x range interactions, for average decel/accel counts (Table 10).

Figures 13-24 profile frequency distributions of average counts for vehicle velocities and decel/accel values using a different analytic approach than that employed for the figures in Appendix G. In particular, with each of these figures, average counts for the five crosswalk distances are compared in one set of histograms for each of the ten velocity or nine decel/accel ranges, across different combinations of type of interaction and type of warning.

Using this approach Figures 13-18 feature plots of average velocity counts for passive warning sites (Figs. 13 and 14), active warning sites (Figs. 15 and 16), and pedestrian-actuated warning sites (Figs. 17 and 18), with the first figure in each of these two-figure sets plotting results for vehicle-crosswalk interactions, and the second plotting results for vehicle-pedestrian

interactions. Using Figure 13 as an example (average velocity counts for vehicle-crosswalk interactions at passive warning sites), average velocity counts are plotted on the ordinate, the ten different velocity ranges are plotted on the abscissa, and each of the ten sets of histograms illustrated in the figure compare average velocity counts at 82.0 ft (25 m) (dark gray bars), 65.6

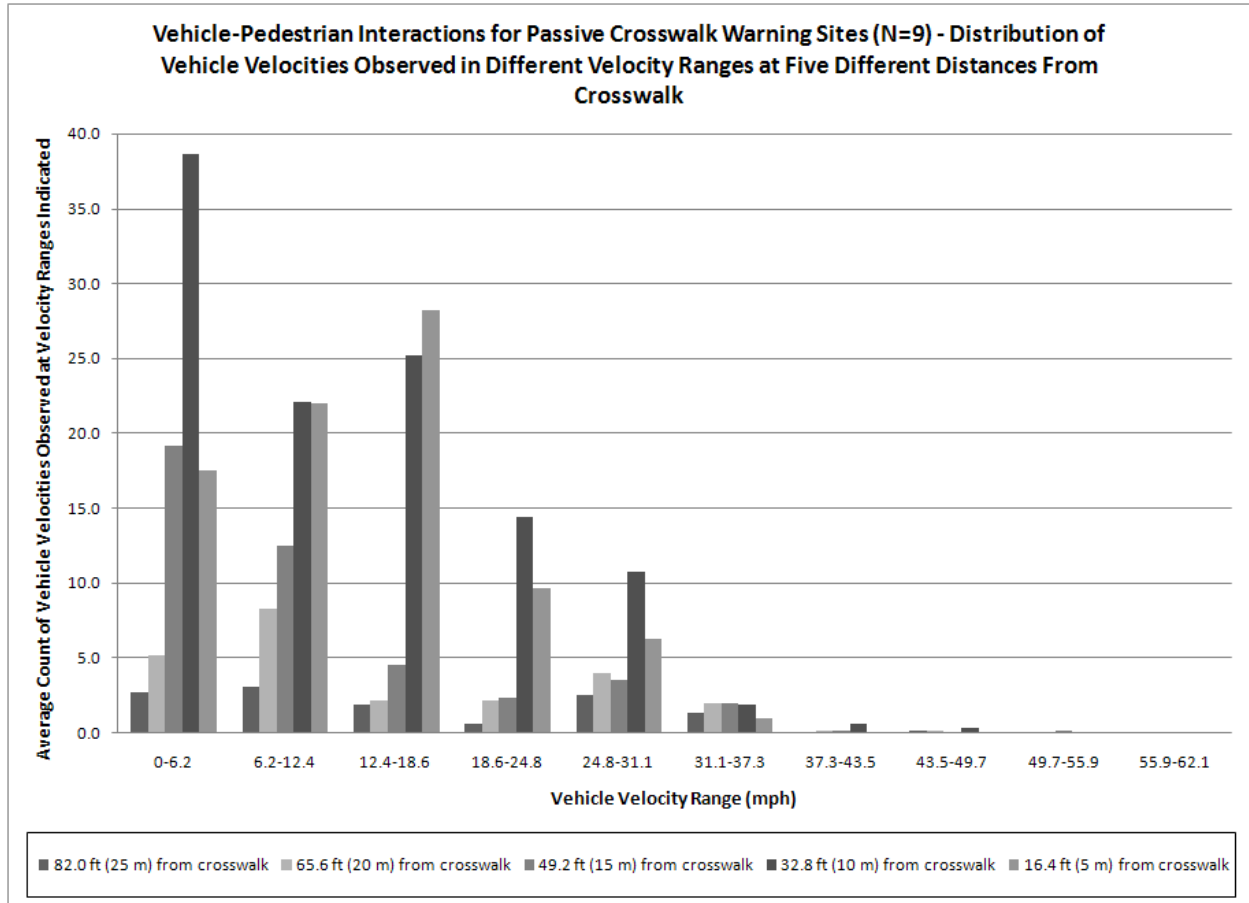

Figure 14. Distribution of average counts for vehicle velocities observed in ten different velocity ranges at five different distances from the crosswalk, for vehicle-pedestrian interactions at passive crosswalk warning sites.

ft (20 m) (very light gray bars), 49.2 ft (15 m) (gray bars), 32.8 ft (10 m) (black bars), and 16.4 ft (5 m) (light gray bars) from the crosswalk.

Figures 19 through 24 plot average decel/accel counts, with the same conditions and sequential organization of figures, as described in the preceding paragraph for average velocity counts.

Results in Figures 13 through 18, for average velocity counts, support the following observations. First, for each of the three warning conditions, the frequency distribution of average velocity counts is roughly comparable for both vehicle-crosswalk and vehicle-pedestrian interactions, even though average count levels for the latter type of interaction are much lower than those for the former type of interaction. Second, for both types of interaction and all crosswalk distances, the preponderance of average velocity counts are observed at the seven lowest velocity ranges (i.e., those between 0 and 43.5 mph) for both active (Figs. 15 and 16) and

pedestrian-actuated (Figs. 17 and 18) crosswalk warning sites. In contrast, for passive crosswalk warning sites (Figs. 13 and 14), most of the average velocity counts are observed at the lowest five velocity ranges (i.e., those between 0 and 31.1 mph), again for both types of interaction and all crosswalk distances. Finally, there is no discernible consistency in the frequency distribution of average velocity counts at different crosswalk distances across successive velocity ranges, for the different combinations of type of interaction and type of warning.

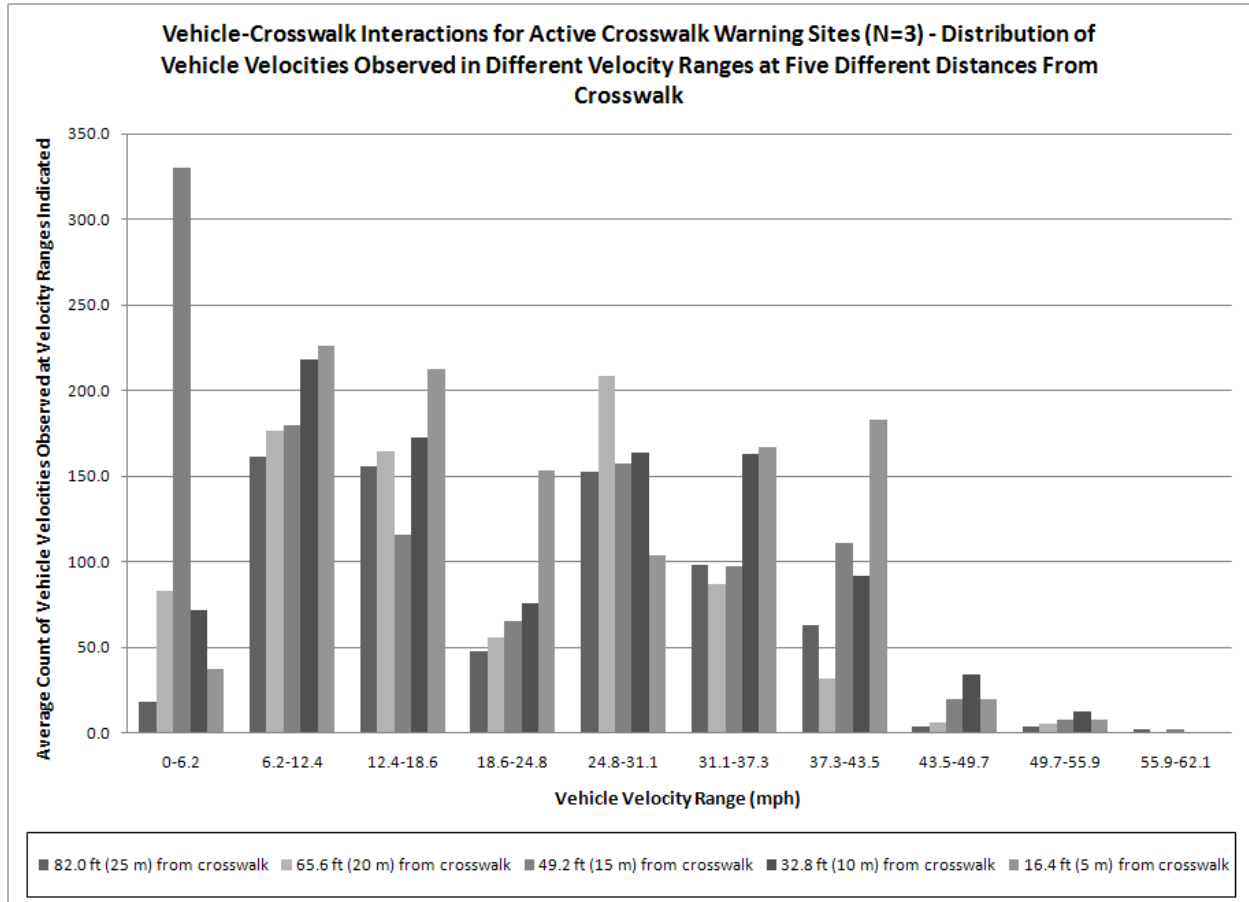

Figure 15. Distribution of average counts for vehicle velocities observed in ten different velocity ranges at five different distances from the crosswalk, for vehicle-crosswalk interactions at active crosswalk warning sites.

Results in Figures 19 through 24, for average counts of decel/accel values, support the following observations. First, for each of the three warning conditions, the frequency distribution of average decel/accel counts is roughly comparable for both vehicle-crosswalk and vehicle-pedestrian interactions, even though average count levels for the latter type of interaction are much lower than those for the former type of interaction. Second, for both types of interaction, for all crosswalk distances, and for passive (Figs. 19 and 20) and active (Figs. 21 and 22) crosswalk warning sites, two groupings of average decel/accel counts with higher values are observed. Specifically, for these two warning conditions, the three lowest decel/accel ranges (i.e., those between -6.6 and +3.3 ft/sec<sup>2</sup>) feature the highest average decel/accel count values, and the two highest accel ranges (i.e., those between +3.3 to +9.8 ft/sec<sup>2</sup>) feature a second

grouping of comparatively high average accel values. In contrast, for the pedestrian-actuated warning sites (Figs. 23 and 24), the highest average decel/accel count levels again are observed for the three lowest decel/accel ranges, but appreciable magnitudes of average decel and accel count levels also are observed at higher decel as well as accel range levels.

Finally, there is one relatively consistent pattern of frequency distributions of average decel/accel counts among the five crosswalk distances for the three lowest decel/accel ranges that prevails across all interaction type and warning type conditions. Specifically, examination of results in Figures 19 through 24 shows that across all 18 sets of histograms for the three

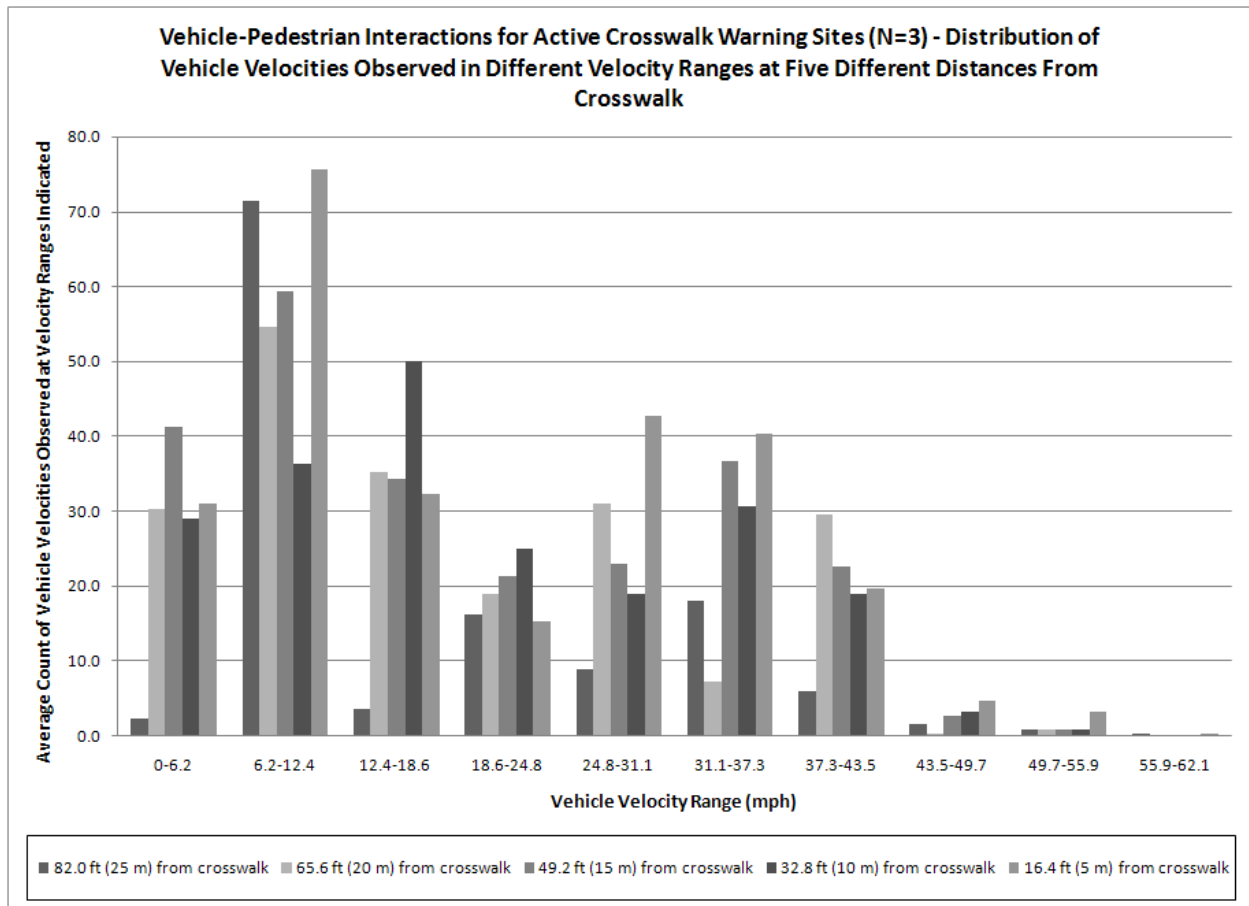

Figure 16. Distribution of average counts for vehicle velocities observed in ten different velocity ranges at five different distances from the crosswalk, for vehicle-pedestrian interactions at active crosswalk warning sites.

lowest decel/accel ranges in these figures (i.e., those between  $-6.6$  and  $+3.3$   $\text{ft}/\text{sec}^2$ ), among data for the five crosswalk distances plotted in each histogram set, average decel/accel counts are either the highest, or the second highest, for crosswalk distances of 32.8 ft (10 m) or 16.4 ft (5 m) from the crosswalk, or both, relative to average counts for the remaining three higher crosswalk distances.

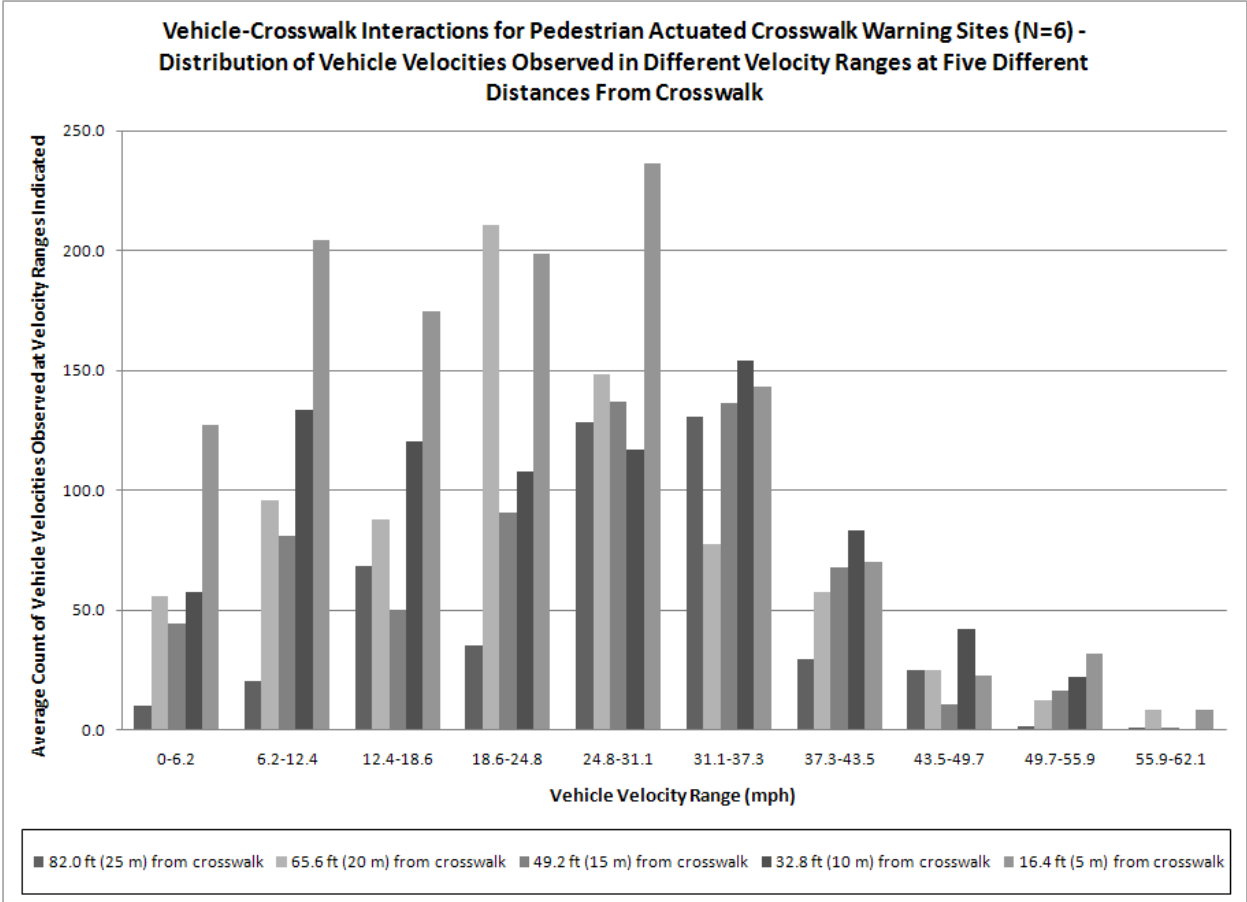

Figure 17. Distribution of average counts for vehicle velocities observed in ten different velocity ranges at five different distances from the crosswalk, for vehicle-crosswalk interactions at pedestrian-actuated crosswalk warning sites.

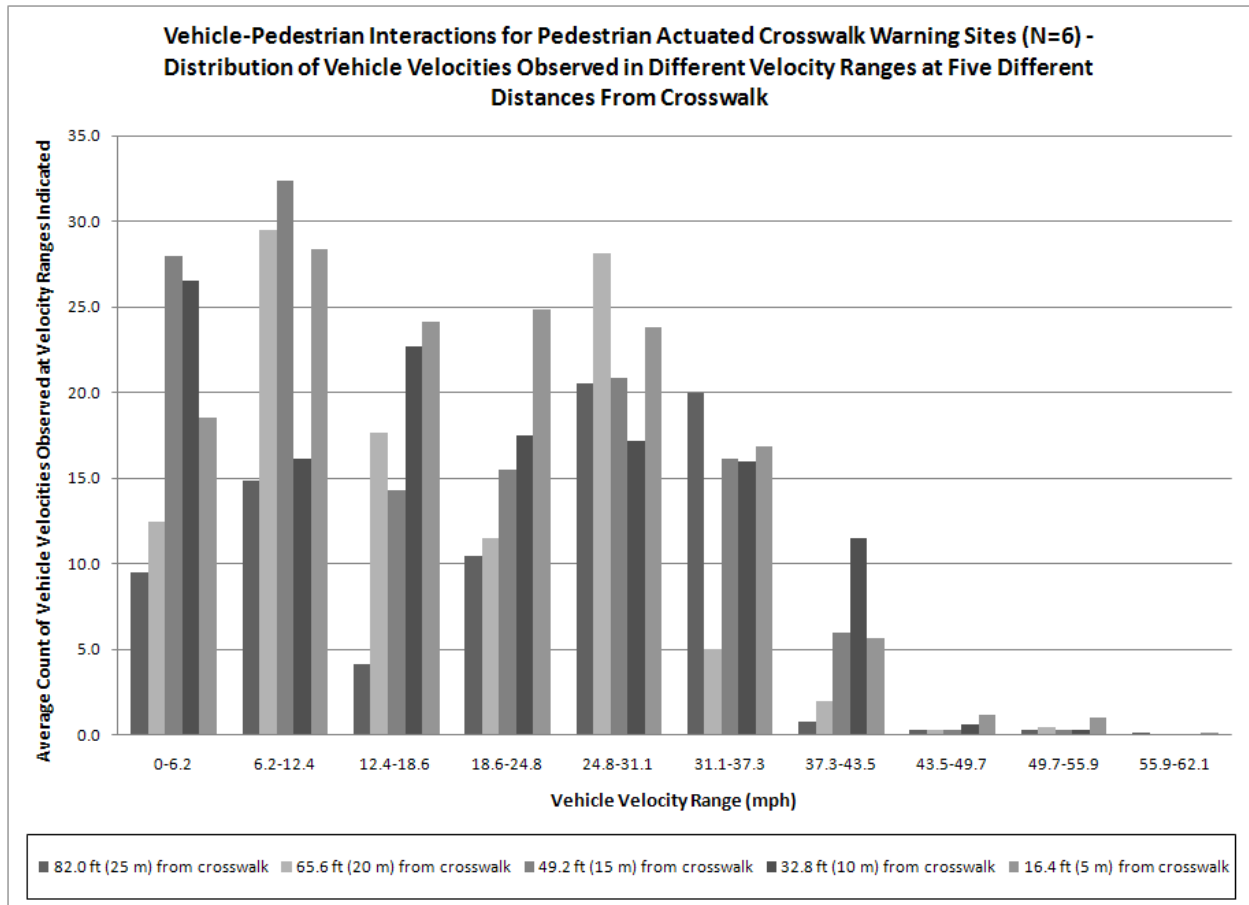

Figure 18. Distribution of average counts for vehicle velocities observed in ten different velocity ranges at five different distances from the crosswalk, for vehicle-pedestrian interactions at pedestrian-actuated crosswalk warning sites.

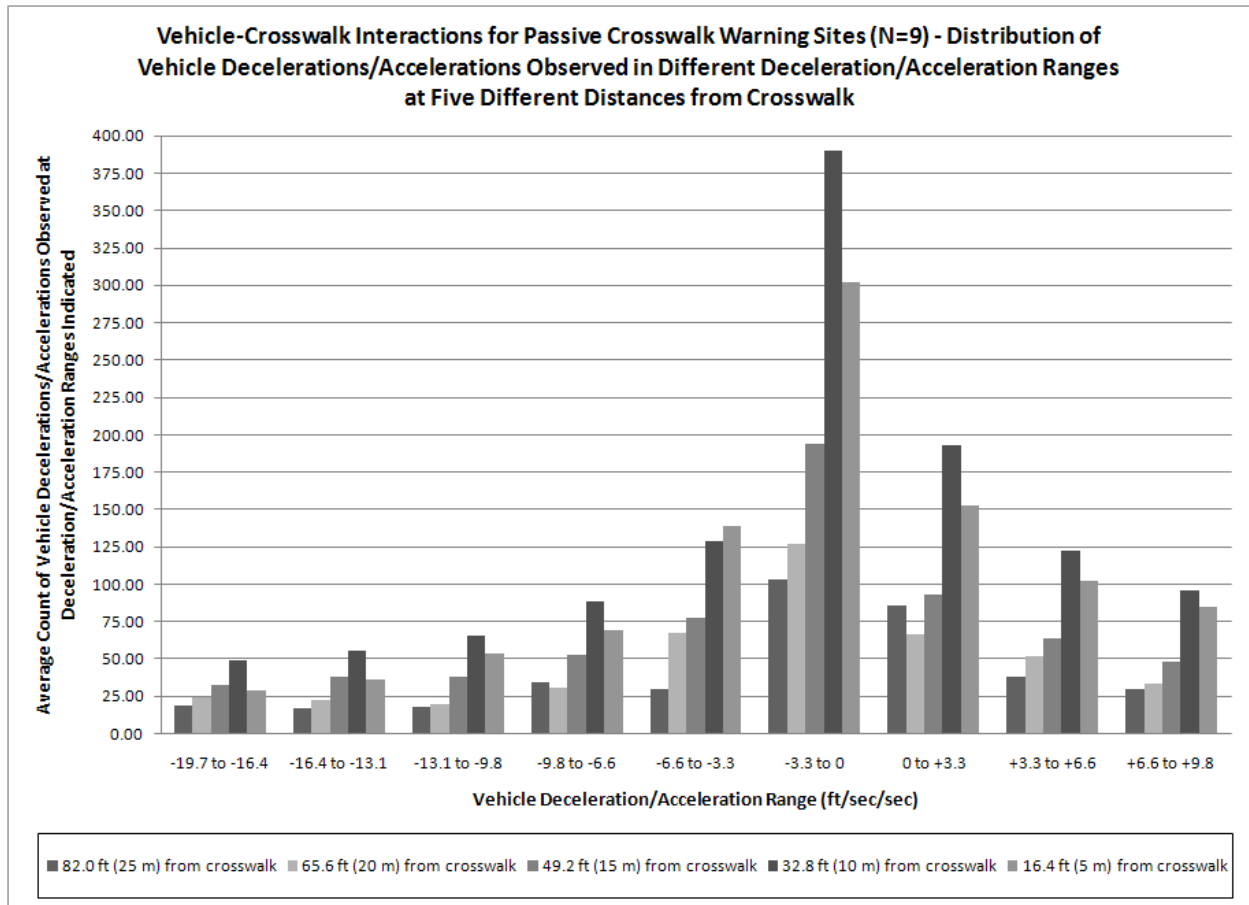

Figure 19. Distribution of average counts for vehicle decel/accel values observed in nine different decel/accel ranges at five different distances from the crosswalk, for vehicle-crosswalk interactions at passive crosswalk warning sites.

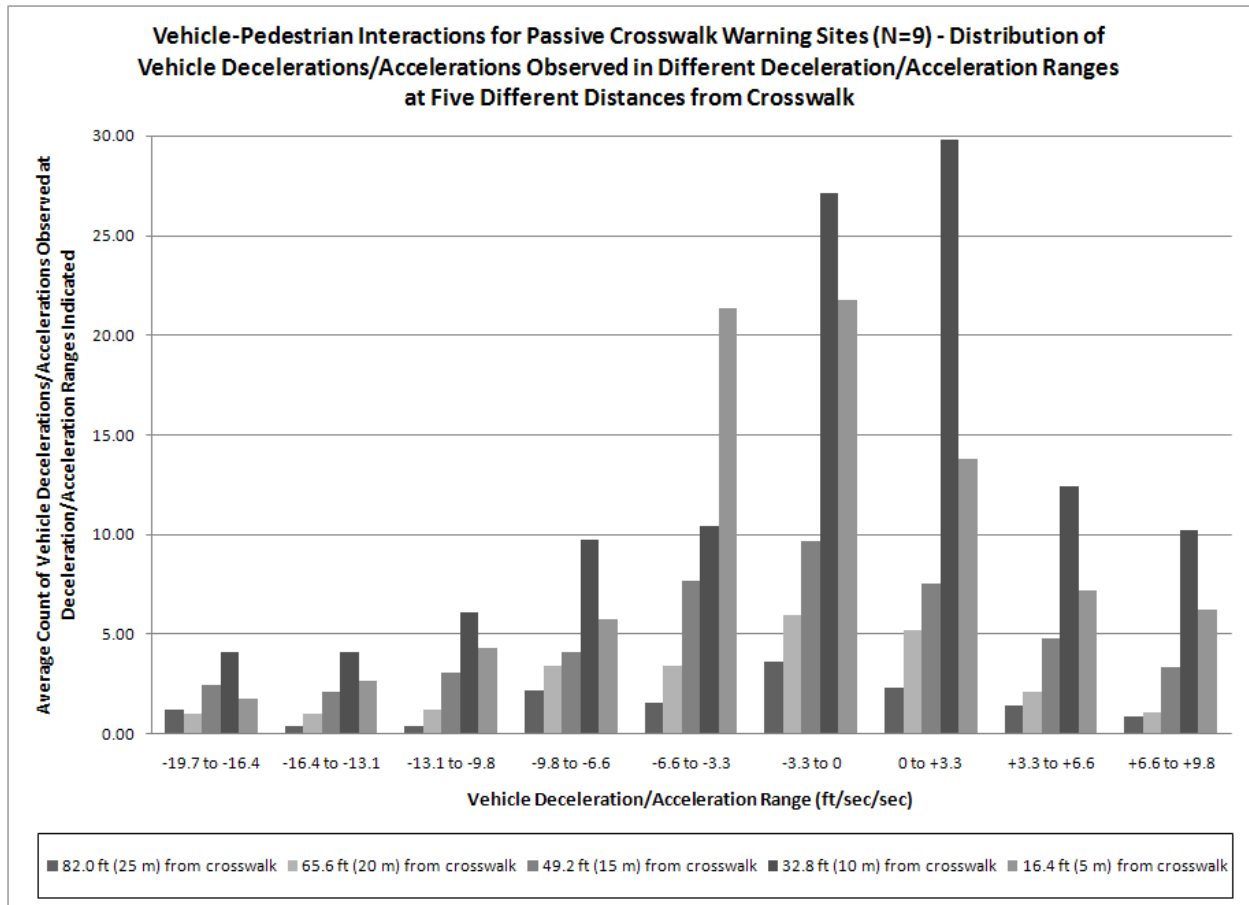

Figure 20. Distribution of average counts for vehicle decel/accel values observed in nine different decel/accel ranges at five different distances from the crosswalk, for vehicle-pedestrian interactions at passive crosswalk warning sites.

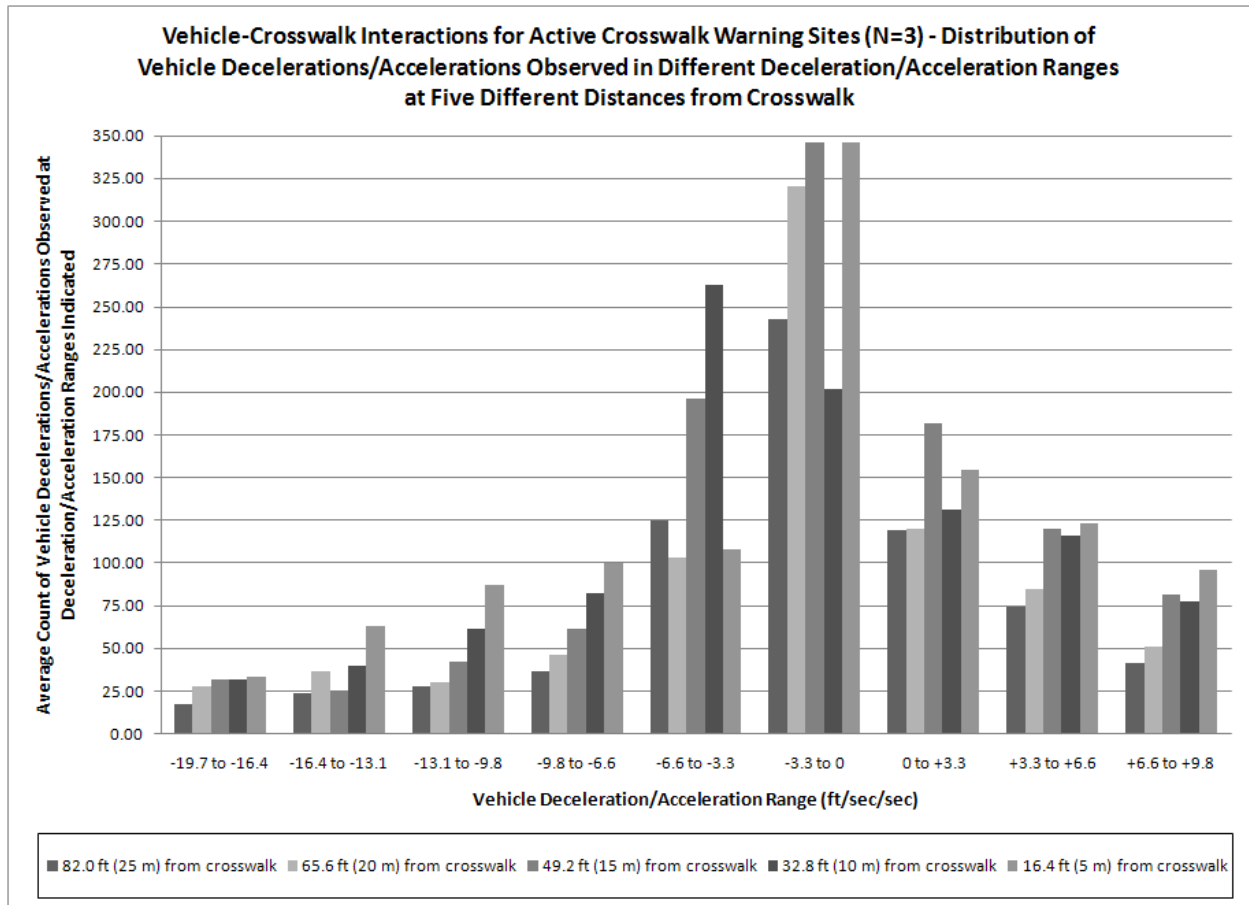

Figure 21. Distribution of average counts for vehicle decel/accel values observed in nine different decel/accel ranges at five different distances from the crosswalk, for vehicle-crosswalk interactions at active crosswalk warning sites.

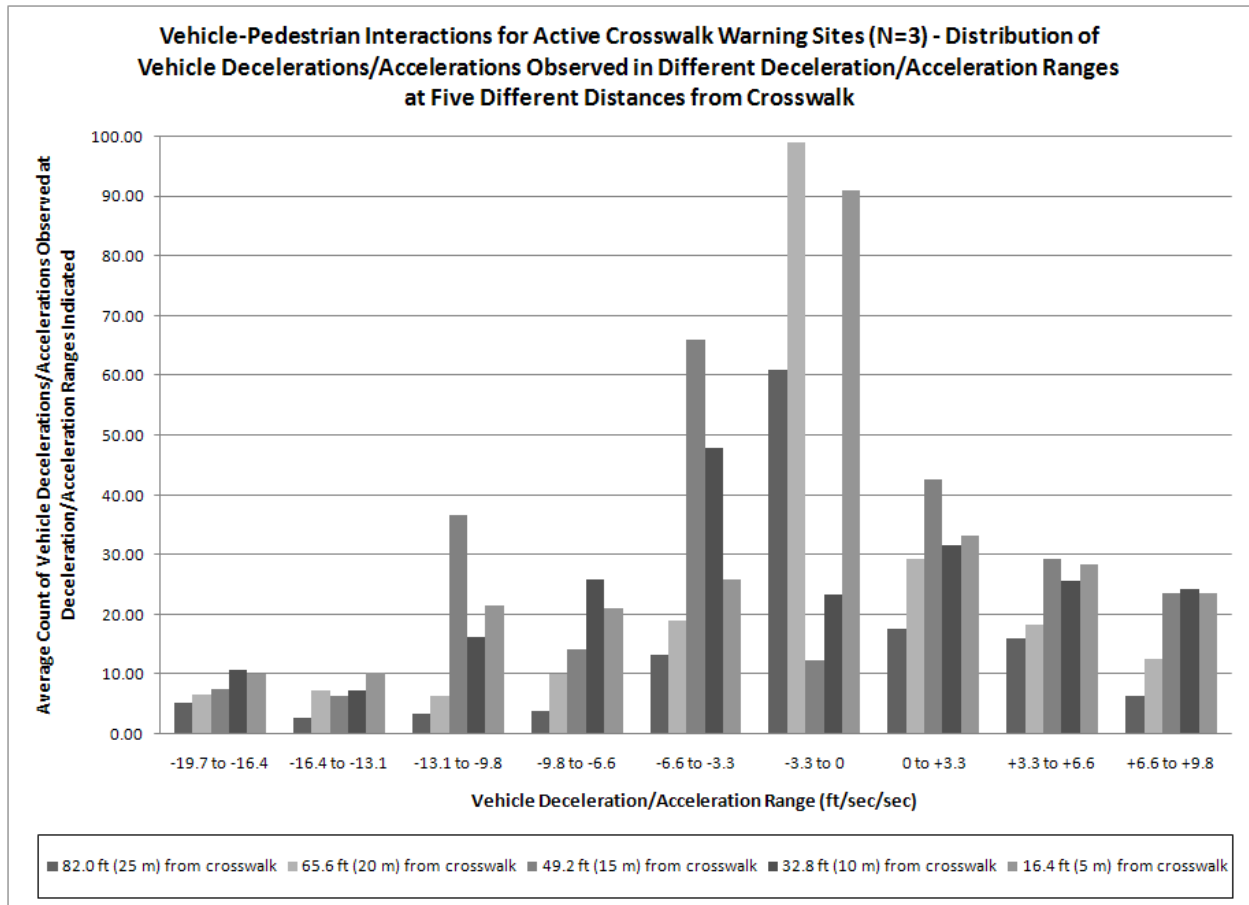

Figure 22. Distribution of average counts for vehicle decel/accel values observed in nine different decel/accel ranges at five different distances from the crosswalk, for vehicle-pedestrian interactions at active crosswalk warning sites.

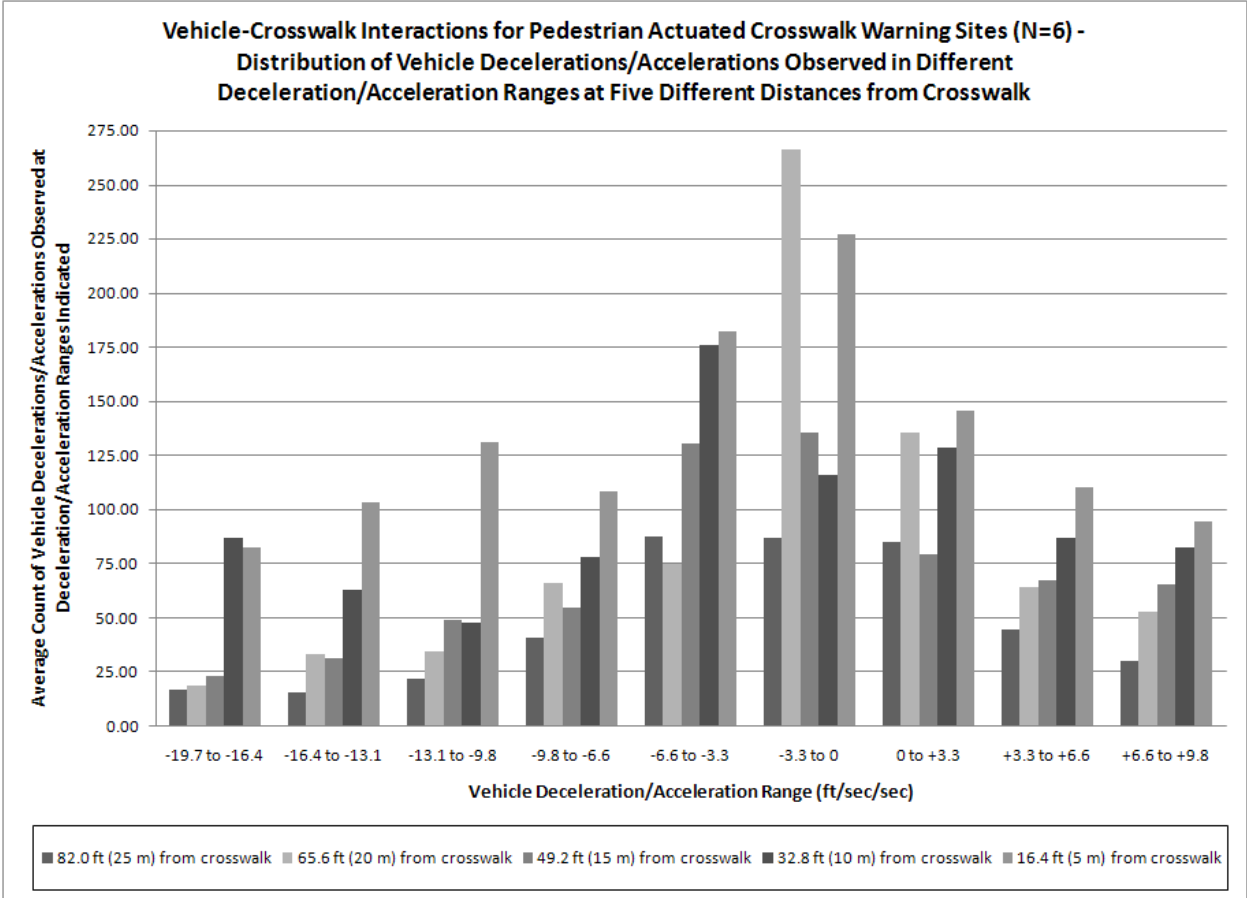

Figure 23. Distribution of average counts for vehicle decel/accel values observed in nine different decel/accel ranges at five different distances from the crosswalk, for vehicle-crosswalk interactions at pedestrian-actuated crosswalk warning sites.

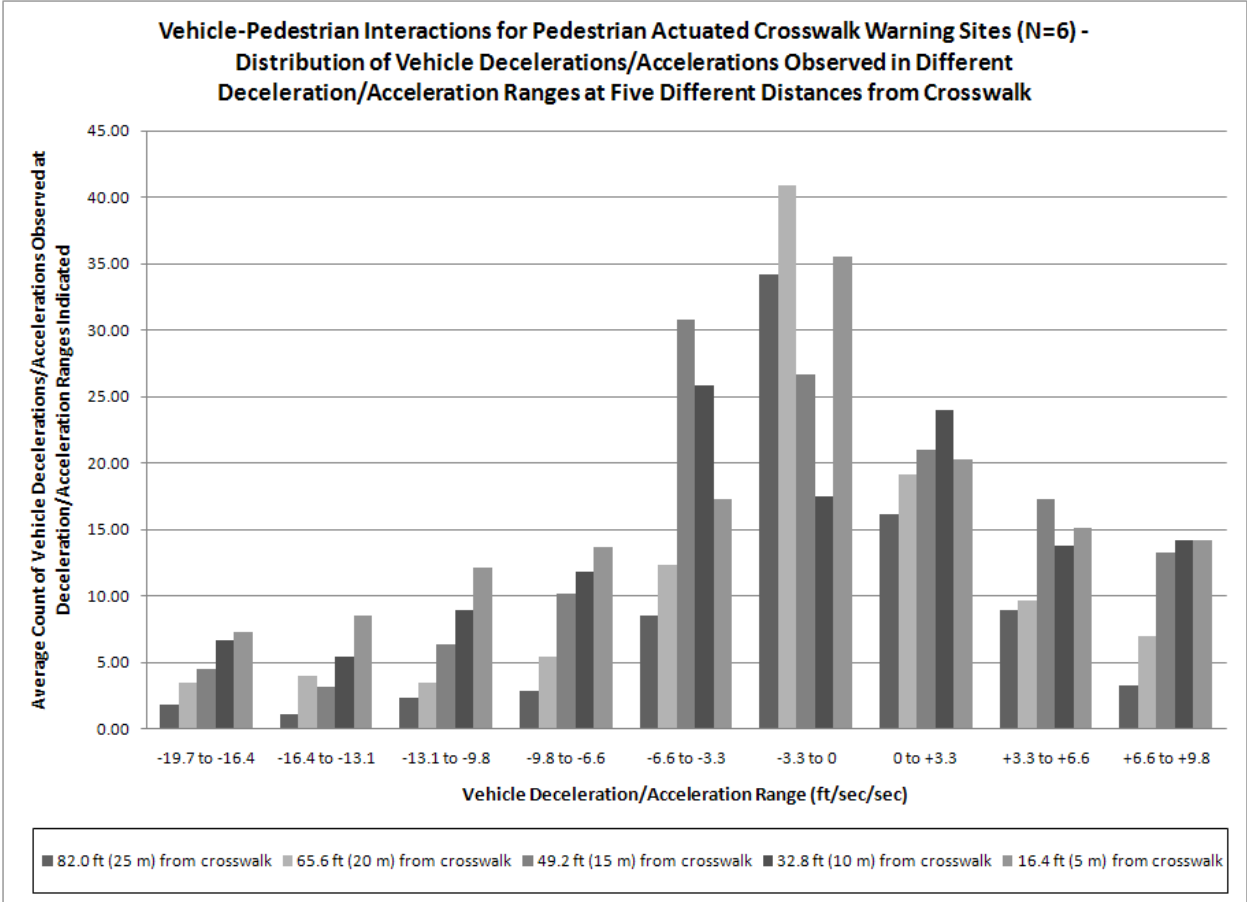

Figure 24. Distribution of average counts for vehicle decel/accel values observed in nine different decel/accel ranges at five different distances from the crosswalk, for vehicle-pedestrian interactions at pedestrian-actuated crosswalk warning sites.

## Chapter 4

### Discussion, Conclusions and Recommendations

This study evaluated the efficacy of active versus passive warnings at uncontrolled pedestrian crosswalks, by comparing how these two warnings types influenced behavior of drivers approaching such crosswalks. Findings show no significant main effect of warning type on average vehicle velocities for either vehicle-crosswalk or vehicle-pedestrian interactions. Various lines of evidence point to a number of sources of ambiguity regarding the salience of uncontrolled crosswalk warnings, resulting in behavioral uncertainty by drivers interacting with such warnings. Support for the null hypothesis by results from this study points to the need for further evaluation of the question of which warning technology will offer the most effective protection of pedestrians using uncontrolled crosswalks.

#### 4.1 Discussion

This study addressed the general question, ‘what is the relative efficacy of passive versus active designs of uncontrolled pedestrian crosswalk warning systems in influencing the behavior of drivers interacting with such crosswalks and with pedestrians using such crosswalks?’

Presumably, the premise behind Mn/DOT’s decision to install active or pedestrian-actuated warnings at some uncontrolled crosswalk sites, as opposed to installation of passive warnings at other crosswalk sites, is the assumption that relative to passive warnings, the former two types of warnings have a greater visibility and salience for the motorist, in terms of calling attention to the crosswalk as well as to its possible use by pedestrians. A further putative premise is that, again relative to passive warnings, more expensive active or pedestrian-actuated warnings are more appropriate for uncontrolled crosswalk sites on roadways with higher vehicular traffic, where there is a greater likelihood of vehicle-pedestrian interactions. This latter premise is born out by findings from this study, which show (Table 4) that compared with frequencies of vehicle-crosswalk and vehicle-pedestrian interactions per site at passive crosswalk warning sites, comparable frequencies per site are about: (1) 1.8 and 4.6 times higher, respectively, for active crosswalk warning sites; and (2) 1.3 and 3.3 times higher, respectively, for pedestrian-actuated crosswalk warning sites.

The human factors/ergonomic (HF/E) perspective on these premises is that different uncontrolled crosswalk warning designs are likely to have distinctive effects on the behavior of both pedestrians and motorists interacting with such warnings. To predict the likely consequences of such effects for behavior of drivers interacting with uncontrolled crosswalks, the conceptual framework adopted here is that of Rogers, Lamson, and Rousseau [27]. Based on their review of the warning literature, these authors conclude that the efficacy of a given warning, in terms of its effects on user behavior during user-warning interaction, is based on four major behavioral stages of the interaction, related to the ability of the user to: (1) notice the warning (i.e., its conspicuity); (2) encode the warning (i.e., generate sensory feedback at the central nervous system level, based on receptors activated during the first stage); (3) comprehend the purpose of the warning (i.e., its salience); and (4) comply with the warning. For purposes of the analysis offered here, it is assumed that these stages rely exclusively on visual feedback provided by an uncontrolled crosswalk warning.

In terms of the conspicuity and encoding stages, two reasonable *a priori* assumptions are that, for a motorist: (1) an active uncontrolled crosswalk warning is more noticeable than a passive uncontrolled crosswalk warning (because visual attention is likely to focus more on

visual feedback from a flashing light, relative to that from a passive sign or roadway marking); and (2) relative to passive crosswalk warning sites, drivers confronting active warnings at uncontrolled crosswalk sites are more likely to display more cautious driving behavior, particularly if a pedestrian is in proximity to the crosswalk. These assumptions support the prediction that the visual reaction time (Stage 4) for a motorist is more rapid during an approach to an active relative to a passive uncontrolled crosswalk warning site. For uncontrolled crosswalks with pedestrian-actuated warnings, the degree to which these predictions obtain may depend upon: (1) whether or not the pedestrian chooses to actuate the warning; and (2) the proximity of the motorist to the crosswalk when the active warning is actuated.

On the other hand, Rogers et al. [27] also assume that the third key behavioral stage of user interaction with a warning relates to the understandability---that is the salience---of the warning. From this perspective, two reasonable predictions are that: (1) because a pedestrian crosswalk warning provides notice of an unpredictable event (i.e., appearance of a pedestrian), it is the event, not the warning, that represents the key salient feature of a uncontrolled crosswalk as far as motorists are concerned; and (2) behavioral responses of motorists to the type of warning design (i.e., passive versus active) therefore should not greatly differ, in that either type of warning gives notice of an unpredictable event that may require adjustment in driving behavior on the part of motorists approaching the crosswalk. The hypothesis that both active and passive uncontrolled crosswalk warnings have a comparable salience (insofar as the motorist is concerned), in calling attention to the crosswalk but only rarely to its user, supports the prediction that visual reaction times for a motorist approaching an uncontrolled crosswalk will be comparable, regardless of the type of warning. Realization of this prediction will support the null hypothesis for the project (Chap. 2) that no main effect of type of warning on any of the dependent measures collected will be observed.

These two contrasting set of predictions provide the basic scientific rationale for the project. That is, given that there appears to be no clear guidance from *a priori* conceptual HF/E analysis as to the relative efficacy of active versus passive warnings in influencing motorist interactions with pedestrians at uncontrolled crosswalks, there is evident need for empirical analysis to address this question.

#### **4.1.1. Findings Regarding the Null Hypotheses**

This section extends the major conclusions listed in Section 4.1 by examining more closely the degree to which findings from the study address the contrasting predictions outlined above. That is, is there a presence or lack of support from these findings for the two key null hypotheses of the study, that no significant effect of either warning condition or interaction condition on average vehicle velocity and decel/accel values will be observed?

The preponderance of findings provide support for the null hypothesis regarding warning condition, as follows.

- As regards average overall velocities and decel/accel values, no significant differences are observed across warning condition, for both types of interaction (Figs. 5 & 7).
- Post-hoc analysis of results from multivariate ANOVA for the main effects of warning type and type of interaction on average vehicle velocities and decel/accel values at different distances from the crosswalk shows that there are no significant differences in average vehicle velocities and decel/accel values across warning condition at any of the five crosswalk distances, for either vehicle-crosswalk (Figs. 8 & 10) or vehicle-pedestrian (Figs. 9 & 11) interactions.

Two findings contradict the null hypothesis for warning condition. Frequency distributions of average counts of observed vehicle velocity levels, across the seven lowest velocity ranges, and of average counts of observed vehicle decel/accel values, across the three lowest accel/decel ranges, show that average counts for active crosswalk warning sites, for both types of interaction, often are higher than those for passive and pedestrian-actuated crosswalk warning sites (Appendix G, Figs. G-1 to G-20). Furthermore, frequency distributions of average counts of observed vehicle decel/accel values, across the three lowest accel/decel ranges, show that average counts for pedestrian-actuated crosswalk warning sites, for both types of interaction, are higher than those for passive crosswalk warning sites (Appendix G, Figs. G-11 to G-20). These patterns indicate that drivers approaching uncontrolled crosswalks with active or pedestrian-actuated warnings tend to adopt somewhat lower vehicle velocities, relative to drivers approaching crosswalks with passive warnings. This finding accords with the prediction outlined above that because an active uncontrolled crosswalk warning is more noticeable than a passive uncontrolled crosswalk warning, drivers interacting with active warnings at uncontrolled crosswalk sites are more likely to display more cautious driving behavior, particularly if a pedestrian is in proximity to the crosswalk.

Results regarding the null hypothesis for interaction condition are mixed. Support for this hypothesis is provided by the following findings.

- As regards average overall velocities, no significant differences are observed across interaction condition for passive and active crosswalk warning sites (Fig. 4).
- As regards average overall decel/accel values, no significant differences are observed across interaction condition, for all three warning conditions (Fig. 6).
- Post-hoc analysis of results from multivariate ANOVA for the main effect of type of interaction on average vehicle velocities at different distances from the crosswalk shows that there are no significant differences in average vehicle velocities across interaction condition at any of the five crosswalk distances, for both passive and active crosswalk warning conditions (Figs. 8 & 9; Table 5).
- Post-hoc analysis of results from multivariate ANOVA for the main effect of type of interaction on average vehicle decel/accel values at different distances from the crosswalk shows that, with one minor exception there are no significant differences in average vehicle decel/accel levels across interaction condition at any of the five crosswalk distances, for all three warning conditions (Figs. 9 & 10; Table 7).

The following results contradict the null hypothesis for interaction condition.

- As regards average overall velocities for pedestrian-actuated warning sites, levels for vehicle-crosswalk interactions are significantly higher than those for vehicle-pedestrian interactions (Fig. 4).
- Post-hoc analysis of results from multivariate ANOVA for the main effect of type of interaction on average vehicle velocities at different distances from the crosswalk shows that, for pedestrian-actuated warning sites, average vehicle velocities for vehicle-crosswalk interactions at the four distances closest to the crosswalk are significantly higher than those for vehicle-pedestrian interactions (Figs. 8 & 9; Table 5). This and the preceding finding indicate that drivers approaching uncontrolled crosswalks with pedestrian-actuated warnings tend to adopt somewhat lower vehicle velocities when a pedestrian is present, relative to drivers approaching such crosswalks when a pedestrian is not present. This finding accords with the prediction outlined above that because the presence of a pedestrian at an uncontrolled crosswalk has greater salience for drivers than

when no pedestrian is present, drivers interacting with a pedestrian at an uncontrolled crosswalk are more likely to display more cautious driving behavior, relative to interactions when a pedestrian is not present.

- Results for frequency distributions in Table 10 show that, with one exception, the only significant main or interactive ANOVA effects on average velocity or decel/accel counts observed are those in which type of interaction is included as one of the independent measures. This finding is unremarkable, given that the average number of observed interactions, and therefore the average number of observed counts, is so much lower for vehicle-pedestrian relative to vehicle-crosswalk interactions.

#### **4.1.2. Conceptual HF/E Analysis of Uncontrolled Pedestrian Crosswalk Warning Systems**

How are we to interpret the findings outlined above regarding the preponderant support for the null hypothesis regarding warning condition, and the mixed findings regarding the null hypothesis for interaction condition, given that these findings appear to contradict basic premises governing Mn/DOT decision-making related to installation of active warnings at selected uncontrolled crosswalks? This section provides a HF/E perspective on this question.

To begin, the rationale for this study rests upon five basic considerations: (1) walking has received increased attention throughout the U.S. and elsewhere as a mode of transportation; (2) in the U.S., pedestrian crashes at uncontrolled crosswalks account for about one-fourth of all such crashes; (3) relative to other types of traffic warning signs, an uncontrolled pedestrian crosswalk warning sign has a more ambiguous salience for both pedestrians and drivers alike; (4) findings from previous research on uncontrolled crosswalks are mixed regarding the relative efficacy of passive versus active warnings in benefiting pedestrian safety; and (5) passive warnings are much less costly than active warnings---it may be argued that investment in the latter is warranted only if the pedestrian safety benefits of active warnings at uncontrolled crosswalks are clearly superior to those of passive warnings. Point 4 was addressed in Chapter 1. The first three of these points are addressed in more detail below.

*Increased interest in pedestrian activity.* In the past two decades, walking has received increased attention throughout the U.S. and elsewhere as a mode of transportation. In 1994 the U.S. Dept. of Transportation proposed to the U.S. Congress that total U.S. trips made by bicycling and walking should double, from 7.9 percent to 15.8 percent of all travel trips [31, pp. 1-2]. The State of Minnesota is a leader in promoting increased facilities and safety for pedestrians [2]. The City of Minneapolis, MN ranks second only to Portland, OR, in the number of people who bike to work [5].

Growing interest in walking and bicycling activity has prompted research attention, both federally and in Minnesota, to the appropriate design of pedestrian and bicycling facilities for both safety and usability [5]. The project described in this report represents an additional contribution to this effort.

*Pedestrian safety statistics.* In the U.S., pedestrian fatalities have dropped gradually over the past 20 years, from about 7,000 to about 5,000 annually [28, p. 8-1]. In 2005, 4,881 pedestrians died and about 64,000 were injured in traffic crashes in the U.S., accounting for ten percent of total traffic fatalities and just over two percent of total injuries [Table 53 in 29]. In Minnesota for the same year, pedestrian fatalities accounted for 7.9 percent of total motor vehicle crash fatalities in the state [4]. A study in the 1990s of crash types for more than 5,000 pedestrian crashes in six U.S. states found that mid-block incidents were the second most prevalent crash type, accounting for 26.5 percent of all such crashes [31, p. 158].

*Ambiguous salience of warnings at uncontrolled crosswalks.* A number of problematic warning system design issues, summarized below, suggest that warnings at uncontrolled crosswalks have an ambiguous salience for both drivers and pedestrians.

Pedestrian right-of-way law. One source of behavioral uncertainty arising out of attempts by either a crosswalk user or a driver to interact with a uncontrolled crosswalk originates with the Minnesota pedestrian right-of-way law. Applicable sections of the law (Minnesota Statute 169.21) read as follows:

## **169.21**

## **PEDESTRIAN**

### **Subdivision 1. Obey traffic-control signals.**

Pedestrians shall be subject to traffic-control signals at intersections as heretofore declared in this chapter, but at all other places pedestrians shall be accorded the privileges and shall be subject to the restrictions stated in this section and Section 169.22 (hitchhiking).

### **Subd. 2. Rights in absence of signal.**

(a) Where traffic-control signals are not in place or in operation, the driver of a vehicle shall stop to yield the right-of-way to a pedestrian crossing the roadway within a marked crosswalk or at an intersection with no marked crosswalk. The driver must remain stopped until the pedestrian has passed the lane in which the vehicle is stopped. No pedestrian shall suddenly leave a curb or other place of safety and walk or run into the path of a vehicle which is so close that it is impossible for the driver to yield. This provision shall not apply under the conditions as otherwise provided in this subdivision.

(b) When any vehicle is stopped at a marked crosswalk or at an intersection with no marked crosswalk to permit a pedestrian to cross the roadway, the driver of any other vehicle approaching from the rear shall not overtake and pass the stopped vehicle.

### **Subd. 3. Crossing between intersections.**

(a) Every pedestrian crossing a roadway at any point other than within a marked crosswalk or at an intersection with no marked crosswalk shall yield the right-of-way to all vehicles upon the roadway.

(b) Any pedestrian crossing a roadway at a point where a pedestrian tunnel or overhead pedestrian crossing has been provided shall yield the right-of-way to all vehicles upon the roadway.

(c) Between adjacent intersections at which traffic-control signals are in operation pedestrians shall not cross at any place except in a marked crosswalk.

(d) Notwithstanding the other provisions of this section every driver of a vehicle shall (1) exercise due care to avoid colliding with any bicycle or pedestrian upon any roadway and (2) give an audible signal when necessary and exercise proper precaution upon observing any child or any obviously confused or incapacitated person upon a roadway.

The human factors perspective offered here is that the operational meanings and therefore the behavioral implications, of the Subdivision 2a specifications, ‘pedestrian crossing the roadway,’ ‘suddenly leaving a curb,’ and ‘walking or running into the path of a vehicle which is so close that it is impossible for the driver to yield’ are inherently uncertain. When does a pedestrian

begin to ‘cross’ a roadway: leaning forward to take the first step onto a crosswalk?; setting one foot, or setting both feet, on the crosswalk?; stepping onto the crosswalk, but then stopping? Arguably, depending upon the individual perspective of a pedestrian or a driver, either none of these behaviors, or all of these behaviors, may be construed as crossing the roadway behavior.

Comparable questions apply to ‘suddenly leaving a curb.’ The exact meaning of ‘sudden behavior’ may vary considerably across individuals, depending upon such factors as gender, age, physical capacity, footwear or clothing worn, and/or objects being carried. Moreover, the temporal characteristics of sudden behavior by a bicyclist may differ considerably from that of a pedestrian. Given these factors, it cannot be assumed that a pedestrian or bicyclist necessarily can make accurate ‘impossibility of yielding’ judgments (i.e., gap judgments) about approaching vehicles. Moreover, a driver approaching a crosswalk may not be able to make accurate judgments of the ‘sudden behavior’ capabilities of a pedestrian or bicyclist at a crosswalk.

It may be argued that potential sources of behavioral uncertainty also reside in Subdivisions 2b and 3a of the above law. When a pedestrian crosswalk crosses a multilane roadway without a raised median (such as the crosswalk at University Ave. and Capitol Street in St. Paul, MN, one of the crosswalks evaluated by this project), a tall vehicle (such as an SUV or truck) stopped in the inside lane for a pedestrian may make it impossible for another vehicle approaching the crosswalk in the outside lane to see a pedestrian crossing from the other side of the roadway. A violation of Subdivision 2b therefore may ensue. Indeed, the findings of Zegeer et al. [12, p. 23] show that, at all average daily traffic (ADT) volumes, pedestrian crash rates at uncontrolled crosswalks crossing multilane roadways with no raised medians are higher than those crossing two-lane roadways.

In light of this analysis, the summation of Fitzpatrick et al. [22, Appendix K, p. 182], based on a survey of pedestrian responses at seven different locales, may be considered broadly if not universally applicable.

‘The unpredictability of drivers remains the number one concern to the pedestrians no matter what type of pedestrian treatment is utilized. Even at highly controlled crossings where all traffic is required to stop, determining whether a vehicle will obey the signal is one of the major concerns of the pedestrians surveyed.’

Lack of understanding of vehicle code. Likely behavioral uncertainty related to stipulations in the pedestrian right-of-way law is exacerbated by confusion about such law on the part of both drivers and pedestrians. In the latest of a series of similar studies, Mitman and Ragland [42] surveyed 192 respondents, and conducted six focus groups of 10-12 participants each comprising both pedestrians and drivers in the San Francisco, CA area, related to respondent knowledge of pedestrian right-of-way law applicable to both marked and unmarked crosswalks (such law has been in force in California for decades). They conclude from their results that, ‘a substantial level of confusion about pedestrian right-of-way law exists.’

In Minnesota, the state legislature in 2008 attempted to address this lack of understanding by including in a transportation funding bill a statute mandating that state driver education programs include content that covers rights of pedestrians and legal responsibilities of drivers when interacting with pedestrians.

Uncertainties in driver and crosswalk user behavior linked to design of warnings installed at uncontrolled crosswalks. A number of potentially ambiguous features pertaining to the design of warning systems installed at uncontrolled crosswalks, addressed below, arguably can be linked to behavioral uncertainty on the part of drivers and pedestrians interacting with such crosswalks.

One such potentially ambiguous warning design feature pertains to different specifications in the Minnesota MUTCD [18] for placement of pedestrian crosswalk warning signs, relative to placement of other traffic warning signs. For the latter, the specification is that traffic warning signs should be placed so that they provide adequate PIEV time [18, Section 2C.5] (the total time needed by a motorist to perceive and complete a reaction to a sign is the sum of the times necessary for Perception, Identification (understanding), Emotion (decision making), and Volition (execution of decision), and is called the PIEV time). The PIEV time can vary from several seconds for general warning signs to six seconds or more for warning signs requiring high road user judgment.

In contrast, as noted above, the Minnesota MUTCD specifies that warning signs at uncontrolled crosswalks be placed immediately adjacent to the crosswalk [18, Section 2C.22]. This specification assumes that the PIEV time for a vehicle approaching such a crosswalk is zero. The putative rationale for this difference, of course, is that pedestrian or bicyclist use of an uncontrolled crosswalk represents an unexpected event, and that application of the PIEV specification for unexpected events (as opposed to traffic conditions which are predictable) is inappropriate. Nevertheless, if the uncontrolled crosswalk warning allows a motorist approaching the crosswalk no time for perception, identification, making a decision, and executing a decision regarding interacting with a pedestrian or bicyclist that may choose to use the crosswalk, then the motorist must rely on other visual cues, such as that of the pedestrian or bicyclist (rather than the warning sign), to carry out effective yielding behavior. In other words, the uncontrolled crosswalk warning sign serves to warn of the existence of the crosswalk, but not of possible use of the crosswalk by a pedestrian or bicyclist. This meaning is fundamentally different from that of other traffic warning signs, a difference that has potential safety implications for users of uncontrolled crosswalks.

Another potentially ambiguous warning design feature relates to the installation of two different types of active warnings at uncontrolled crosswalks, namely continuously flashing or pedestrian-actuated warnings. The Minnesota MUTCD defines an active uncontrolled crosswalk warning as a 'warning beacon' [18, Section 4K.3]. Two applications specified for such beacons are: (1) as supplemental emphasis to warning signs; and (2) as emphasis for mid-block crosswalks. The question raised here is what sort of 'emphasis' is provided to motorists if two alternative modes of active warnings may be encountered?

It can be argued that a continuously flashing active uncontrolled crosswalk warning may be more noticeable by motorists than passive signs and roadway markings. Yet for any given motorist encountering an uncontrolled crosswalk, a flashing warning rarely is accompanied by the putative target of the warning, namely a pedestrian or bicyclist approaching or using the crosswalk. As such 'unrewarded' crosswalk encounters are repeated over time, that motorist is likely to become desensitized to the significance of the warning (a prediction supported by basic principles and findings of behavioral psychology). In other words, as argued above for the passive uncontrolled crosswalk warning sign, a continuously active flashing uncontrolled crosswalk warning primarily serves to warn of the existence of the crosswalk, but not of possible use of the crosswalk by a pedestrian or bicyclist. Given the likelihood that both active and passive uncontrolled crosswalk warnings have a comparable salience (insofar as the motorist is concerned) in calling attention to the crosswalk, but only rarely to its user, it is not clear (at least to the authors of the present study) what additional pedestrian safety benefits are provided by an active warning relative to a passive warning.

In theory, a pedestrian-actuated active flashing uncontrolled crosswalk warning overcomes the shortcomings of a continuously flashing active uncontrolled crosswalk warning, inasmuch as the former only flashes when actuated by a pedestrian at the crosswalk, thereby warning unequivocally of the crosswalk user. The problem here is that pedestrian or bicyclist users of uncontrolled crosswalks equipped with active pedestrian-actuated warnings usually do not actually activate the warning in preparation for crossing. For example, Fitzpatrick et al. [14, p. 58] report that only 28 percent of observed pedestrians actuated pedestrian-actuated yellow flashing warnings at uncontrolled crosswalks. Given these results, the putative emphasis provided by the pedestrian-actuated active crosswalk warning obtains only occasionally, and the pedestrian safety benefits provided by this type of active crosswalk warning therefore are likely to be only intermittently realized.

Yet a third potentially ambiguous warning design feature pertains to inconsistency in the application of Minnesota MUTCD specifications for appropriate crosswalk warning signage for pedestrians versus bicyclists. As noted above, the Minnesota MUTCD specifies use of different uncontrolled crosswalk warning signs for bicycle crosswalks versus pedestrian crosswalks [18, Sections 2C.21 and 2C.22]. Yet this project has noted a number of uncontrolled crosswalks marked by pedestrian warning signs that receive regular use by bicyclists. An example is various uncontrolled roadway crosswalks for the Gateway State Trail, a popular bicycling trail in the northeast Twin Cities metropolitan area. With this type of inconsistent warning signage, an approaching motorist may expect pedestrians rather than bicyclists as typical users of the crosswalk. The possible implications of this inconsistency for the safety of bicyclists using such crosswalks remains to be established.

## 4.2. Conclusions

Methods and results presented in Chapters 2 and 3, coupled with the HF/E analysis of uncontrolled crosswalk warning systems provided above, support the following conclusions.

1. Two methodological innovations were developed for the study. The first is a modular camera boom system that readily can be assembled and disassembled, to enable collection of video data of vehicle behavior at different crosswalk sites in a rapid and flexible manner (Section 2.3.1).
2. The second methodological innovation is a computer vision software platform that can automatically track the position of moving vehicles from frame to frame in video records collected with the camera boom system described in Conclusion 1, and can use this tracking information to automatically compute vehicle velocity and decel/accel values at selected roadway positions and vehicle-crosswalk distances for each vehicle observed (Section 2.3.2).
3. Vehicle-crosswalk interactions were observed at 18 crosswalk sites with passive (N=9), active (N=3), or pedestrian-actuated (N=6) crosswalk warnings, yielding 7,305 vehicle-crosswalk interactions (no pedestrian present at the crosswalk), and 596 vehicle-pedestrian interactions (pedestrian approaching or present at the crosswalk) (Table 4). Vehicle velocities and decel/accel values were averaged for each individual interaction, and aggregate averages for multiple interactions were calculated and categorized by type of interaction, and by type of warning, for five different discrete distances from the crosswalk.
4. Findings from this study regarding the effects of both warning condition (i.e., passive versus active crosswalk warning type) and interaction condition (i.e., pedestrian absent

versus pedestrian present vehicle-crosswalk interactions) are mixed. Specifically: (1) two findings indicate that warning condition has no significant effect on the dependent measures, whereas two other findings indicate that warning condition does have a significant effect on the dependent measures; and (2) four findings indicate that interaction condition has no significant effect on the dependent measures, whereas two other findings indicate that interaction condition does have a significant effect on the dependent measures

5. The interpretation offered for these mixed results is that there is an ambiguity inherent to the salience of warning signs at uncontrolled pedestrian crosswalks, in that the warning refers to an event (i.e., arrival of a pedestrian in proximity to the crosswalk) that may or may not actually occur at the time a given motorist approaches the crosswalk (Section 4.1.2). Because of this ambiguity, we hypothesize that most motorists approaching an uncontrolled crosswalk tend to pay more attention to whether or not a pedestrian is present in proximity to the crosswalk, rather than to the type of crosswalk warning. In other words, the most critical salient feature of an uncontrolled crosswalk for a motorist approaching the crosswalk is the presence or absence of a pedestrian, rather than the crosswalk warning condition. This we believe accounts for the mixed results for both warning condition and interaction condition observed in this study.
6. Conclusion 5 suggests that the efficacy of warnings at uncontrolled crosswalks in protecting the safety of users of such crosswalks may be inherently limited. If the presence of a pedestrian at an uncontrolled crosswalk is the most critical salient feature of the crosswalk, insofar as influencing the driving behavior of motorists approaching the crosswalk is concerned, then a reasonable assumption is that pedestrian-actuated warnings should be more effective than other types of warnings in terms of promoting more cautious driving behavior of motorists interacting with uncontrolled crosswalks. However, other studies have shown that pedestrian or bicyclist users of uncontrolled crosswalks equipped with active pedestrian-actuated warnings usually do not actually activate the warning in preparation for crossing [14, p. 58], a finding recapitulated by informal observations of researchers in this study
7. Conclusion 6 suggests that pedestrian-actuated warnings at uncontrolled crosswalks likely will achieve their full potential as effective warnings (relative to other types of warnings) only if pedestrians approaching in proximity to such crosswalks are no longer required to play an active role in actually actuating the warning. This idea leads to a key recommendation of this study, presented in the next section.

### **4.3. Recommendations**

At the outset of this project, there were two starkly contrasting recommendations growing out of the findings that arguably could be anticipated, based on the experimental design of the research. If the null hypothesis predicting no significant effect of warning condition on the dependent measures was supported by the findings, a conceivable recommendation would be to install only passive warning systems at uncontrolled crosswalks, given that active warning systems are no more effective than passive warning systems in influencing the behavior of drivers interacting with uncontrolled crosswalks (based on findings supporting the null hypothesis).

Implementation of such a recommendation undoubtedly would result in cost savings for transportation departments. It also is conceivable that the impact of such a change on pedestrian

safety at uncontrolled crosswalks might be minimal, given that: (1) findings from the limited number of past studies with a comparable experimental design are mixed (Section 1.2.3), with one study reporting no positive impact on driver behavior of replacing passive with active warnings at uncontrolled crosswalks, but with two other studies reporting that replacing passive with active warnings does have a positive impact on driver behavior; and (2) the conceptual HF/E analysis of uncontrolled crosswalk warnings offered above (Section 4.1.2) argues that it is the salience of the presence or absence of a pedestrian at a crosswalk, not the salience of the warning itself, that represents the critical influence on the behavior of drivers interacting with the crosswalk.

On the other hand, it also is possible that promulgation of such a recommendation would prove unpalatable to the public, to lawmakers, and/or to the professional surface transportation community, given a prevailing perception among members of all of these interest groups that, relative to passive crosswalk warnings, active crosswalk warnings are more beneficial for pedestrian safety at uncontrolled crosswalks. One line of evidence supporting this assumption is that active warnings have continued to be installed at uncontrolled crosswalks without compelling research evidence showing that such warnings benefit pedestrian safety, relative to passive warnings at uncontrolled crosswalks.

If the null hypothesis predicting no significant effect of warning condition on the dependent measures was not supported by the findings, a contrasting recommendation would be to maintain the status quo---that is, retain the current system that features use of both passive and active crosswalk warnings at uncontrolled crosswalks. Promulgation of such a recommendation would continue to burden transportation departments with the higher costs required for installation of active relative to passive crosswalk warnings. It is probable that the impact of maintaining the status quo on pedestrian safety at uncontrolled crosswalks would be minimal, because no change in the current uncontrolled crosswalk warning systems would have occurred. Not changing the current system also would be uncontroversial for different interest groups. In other words, except for the cost factor, maintaining the current system is a relatively safe bet.

On the other hand, maintaining the status quo essentially ignores empirical research pointing to a lack of compelling evidence that active warnings at uncontrolled crosswalks preferentially benefit pedestrian safety, relative to passive crosswalk warnings. That is, maintaining the current system may be politically and technically palatable, but scientific support for this approach is weak at best.

Do actual findings from this project lend support to either of these contrasting recommendations? Because support for the null hypotheses by the results is in fact mixed, the answer to this query is negative. This raises the question as to whether a recommended approach to warning design at uncontrolled crosswalks might be identified that combines the virtues of both cost savings and pedestrian safety benefits.

The following considerations suggest that there may be a positive answer to at least the latter part of this query. First, two of three previous studies with an experimental design comparable to the present study found that, relative to passive warnings, active warnings at uncontrolled crosswalks tend to encourage more cautious driving behavior on the part of drivers interacting with such crosswalks (Section 1.2.3). Similarly, in the present study, two results growing out of analysis of frequency distributions of average vehicle velocity and decel/accel counts point to the same conclusion (Conclusion 4). With average velocity counts, these results apply to active crosswalk warnings; with average decel/accel counts, these results apply to pedestrian-actuated warnings. Furthermore, there two results in the present study showing that, compared to

conditions when a pedestrian is not present, drivers are more cautious approaching pedestrian-actuated crosswalk warning sites when a pedestrian is present.

These findings suggest that, relative to passive crosswalk warnings, active crosswalk warnings generally, and pedestrian-actuated crosswalk warnings particularly, may promote more cautious behavior on the part of drivers interacting with uncontrolled crosswalks. However, there are contrasting results from this study that indicate no significant effect of warning condition as well as interaction condition on the dependent measures, and that therefore argue against this conclusion. Moreover, as noted in Conclusion 6, pedestrians approaching a crosswalk with a pedestrian-actuated warning often do not actuate the warning.

Collectively, these considerations point to a recommended approach for designing active warning systems for uncontrolled crosswalk sites on roadways where traffic volume is so heavy that pedestrians may experience excessive delay in crossing (Section 1.2). As envisioned with this approach, the salience of the design should emphasize the presence of a pedestrian in proximity to the crosswalk, not the presence of the warning itself. As noted previously, continuously active crosswalk warning designs do not meet this criterion, because they are active whether or not a pedestrian is present. Pedestrian-actuated crosswalk warnings, as currently configured, do not meet this criterion, because they require intentional behavior on the part of the pedestrian to be actuated properly, behavior that cannot always be counted on. As noted in Conclusion 7, pedestrian-actuated warnings at uncontrolled crosswalks likely will achieve their full potential as effective warnings (relative to other types of warnings) only if pedestrians approaching in proximity to such crosswalks are no longer required to play an active role in actually actuating the warning.

The computer vision software platform used with the present project suggests that adaptation of this technology for automated pedestrian detection may represent both a feasible and a practical approach for automatically actuating an active warning only when a pedestrian approaches in proximity to the crosswalk. Such a design would combine the virtues of an active warning with a salience that reliably emphasizes the presence of a pedestrian. Indeed, a current Mn/DOT-funded project at the UM Artificial Intelligence Robotics and Vision Laboratory, directed by Prof. Nikolaos Papanikolopoulos, is aimed at using computer vision software to automatically detect bicyclists---extension of this technology to automated detection of pedestrians would appear to be conceptually feasible.

These ideas provide a rationale for the following three project recommendations.

### **Recommendation 1**

Eliminate the requirement that pedestrians preparing to cross an uncontrolled crosswalk equipped with a pedestrian-actuated warning must engage in intentional behavior (i.e., depressing a control button) in order to activate the warning.

### **Recommendation 2**

To implement the goal advocated in Recommendation 1, explore the feasibility and practicality of adapting computer vision technology to enable automated detection of pedestrians approaching uncontrolled crosswalks, and of using intelligent decision-making software linked to such technology to automatically actuate an active warning system situated at the crosswalk when pedestrians are detected approaching the crosswalk.

### **Recommendation 3**

Depending upon the outcome of the feasibility analysis advocated under Recommendation 1, consider: (1) replacing current continuously active and pedestrian-actuated warnings at uncontrolled crosswalks with active warnings that are automatically actuated only when a pedestrian is detected; and (2) evaluating the impact of this change on driver behavior at uncontrolled crosswalks. Depending upon cost and traffic engineering considerations, replacing passive warnings at selected uncontrolled crosswalks with automatically actuated active warnings also should be considered.

A fourth recommendation is prompted by one of the limitations of the study cited in Section 2.6. Namely, among the uncontrolled crosswalks observed during this study, the observations did not document the degree to which use of the crosswalks may have been accessible by pedestrians with disabilities. In this regard, at least two accessibility issues on the part of disabled pedestrians may be identified: (1) detection of the existence of a crosswalk; (2) detection of the degree to which the crosswalk warning may be influencing the driving behavior of motorists approaching the crosswalk; and (3) accessibility and usability of the warning control button at crosswalks equipped with pedestrian-actuated warnings. Recently, the U.S. Federal Highway Administration has called for state highway departments (including Mn/DOT) to ensure that pedestrian crosswalks are accessible for use by disabled users (Mary Jackson, personal communication), under provisions of the Americans with Disabilities Act (ADA). That is, because pedestrian crosswalks are designed to be used by the general public, the ADA stipulates that the design of these crosswalks meets accessibility provisions of the act. This stipulation supports the following recommendation.

### **Recommendation 4**

Ensure that uncontrolled pedestrian crosswalks (including their warning systems) will be detectable by and usable by pedestrians with disabilities, under provisions of the ADA.

It should be noted that the application of computer vision technology for detection of approaching pedestrians, advocated under Recommendations 2 and 3, should substantially address the objective of Recommendation 4.

## References

1. J.J. Fruin, 'Pedestrian Accident Characteristics in a One-Way Grid,' *Highway Research Record*, Issue 436 (1973), pp. 1-7.
2. K. Krizek, G. Poindexter, A. El-Geneidy, and E. Sanderson, *The Safety of Pedestrian and Bicycle Travel in Minnesota: Inventory, Analysis, and Prospectus*, Minnesota Department of Transportation Report MN/RC 2007-04 (St. Paul, MN: Minnesota Department of Transportation, 2007).
3. National Highway Traffic Safety Administration, National Center for Statistics & Analysis, *Motor Vehicle Traffic Crash Fatalities and Injuries – 2005 Projections*, Report DOT HS 810 583 (Washington, D.C.: National Highway Traffic Safety Administration, 2006).
4. National Highway Traffic Safety Administration, National Center for Statistics & Analysis, *Traffic Safety Facts, Minnesota, 2005* (Washington, D.C.: National Highway Traffic Safety Administration, 2006).
5. T. Harlow, 'Biking to Work? So are 4,700 in Minneapolis,' *Minneapolis Star Tribune*, 29 June 2007, p. B5.
6. L. Blake, 'Movement Grows to Get Us Out of Our Cars,' *Minneapolis Star Tribune*, 7 March 2007, p. B5.
7. S. Brandt, 'Fewer Cars, More Bikes in Minneapolis' Future,' *Minneapolis Star Tribune*, 30 June 2007, p. B3.
8. F. Melo, 'Program Aims to Motivate Walkers,' *St. Paul Pioneer Press*, 12 July 2007, p. 2B.
9. Mary Jane Smetanka, 'Suburbs Shift Gears, Make Room for Bikes,' *Minneapolis Star Tribune*, 23 July 2007, pp. B1,B5.
10. L. Blake, 'Lessons in Leg Power,' *Minneapolis Star Tribune*, 21 February 2007, p. A1.
11. U.S. Department of Transportation, Bureau of Transportation Statistics, *Bicycle and Pedestrian Data: Sources Needs, & Gaps*, Report BTS00-02 (Washington, D.C.: U.S. Department of Transportation, 2000).
12. C.V. Zegeer, J.R. Stewart, H.H. Huang, P.A. Lagerwey, J. Feaganes, and B.J. Campbell, *Safety Effects of Marked versus Unmarked Crosswalks at Uncontrolled Locations: Final Report and Recommended Guidelines*, FHWA Publication Number HRT-04-100 (McLean, VA: U.S. Department of Transportation, Federal Highway Administration, Turner-Fairbank Highway Research Center, 2005).
13. Transportation Research Board Pedestrians Committee, *Pedestrians – Research Problem Statements*, Transportation Research Circular E-C084 (Washington, D.C.: Transportation Research Board, 2005).
14. K. Fitzpatrick, S. Turner, M. Brewer, P. Carlson, B. Ullman, N. Trout, E.S. Park, J. Whitacre, N. Lalani, and D. Lord, *Improving Pedestrian Safety at Unsignalized Crossings*, Transit Cooperative Research Program Report 112, National Cooperative Highway Research Program Report 562 (Washington, D.C.: Transportation Research Board, 2006).
15. F. Harvey, and K. Krizek, *Commuter Bicyclist Behavior and Facility Disruption*, Minnesota Department of Transportation Report MN/RC 2007-15 (St. Paul, MN: Minnesota Department of Transportation, 2007).
16. National Committee on Uniform Traffic Laws and Ordinances, *Uniform Vehicle Code and Model Traffic Ordinance 2000* (Arlington, VA: National Committee on Uniform Traffic Laws and Ordinances, 2000).

17. T.J. Smith, C. Hammond, and M. Wade, *Investigating the Effect on Driver Performance of Advanced Warning Flashers at Signalized Intersections, Final Report*, Report MN/RC - 2002-05 (St. Paul, MN: State of Minnesota Department of Transportation, 2001).
18. Minnesota Department of Transportation, *Minnesota Manual on Uniform Traffic Control Devices, Revision 1* (St. Paul, MN: Minnesota Department of Transportation, 2007).
19. State of Minnesota Department of Public Safety, *Minnesota Driver's Manual* (St. Paul, MN: State of Minnesota Department of Public Safety, 2007).
20. Emily Gurnon, 'Cyclist Gets Split Verdict in Police Run-In,' *St. Paul Pioneer Press*, 21 July 2007, pp. 1B,4B.
21. A.J. Chapman, F.M. Wade, and H.C. Foot, *Pedestrian Accidents* (New York: Wiley, 1982).
22. K. Fitzpatrick, S. Turner, M. Brewer, P. Carlson, B. Ullman, N. Trout, E.S. Park, J. Whitacre, N. Lalani, and D. Lord, *Improving Pedestrian Safety at Unsignalized Crossings, Appendices B to O*, Transit Cooperative Research Program Report 112, National Cooperative Highway Research Program Report 562 (Washington, D.C.: Transportation Research Board, 2006).
23. G.A. Davis, K. Sanderson, and S. Davuluri, *Development and Testing of a Vehicle/Pedestrian Collision Model for Neighborhood Traffic Control*, Minnesota Department of Transportation Report MN/RC 2002-23 (St. Paul, MN: Minnesota Department of Transportation, 2002).
24. L. Sandt and C.V. Zegeer, 'Characteristics Related to Midblock Pedestrian-Vehicle Crashes and Potential Treatments,' *Transportation Research Record*, vol. 1982 (2006), pp. 113-121.
25. X. Chu, M. Guttenplan, and M.R. Baltes, 'Why People Cross Where They Do. The Role of Street Environment,' *Transportation Research Record*, vol. 1878 (2004), pp. 3-10.
26. Z. Cui and S.S. Nambisan, 'Methodology for Evaluating the Safety of Midblock Pedestrian Crossings,' *Transportation Research Record*, vol. 1828 (2003), pp. 75-82.
27. W.A. Rogers, N. Lamson, and G.K. Rousseau, 'Warning Research: An Integrative Perspective.' *Human Factors*, vol. 42, no. 1 (2000), pp. 102-139.
28. J.H. Hedlund and W.A. Leaf, *Countermeasures That Work: A Highway Safety Countermeasure Guide for State Highway Safety Offices* (Washington, D.C.: National Highway Traffic Safety Administration, 2007).
29. National Highway Traffic Safety Administration, National Center for Statistics & Analysis, *Traffic Safety Facts*, Report DOT HS 810 631 (Washington, D.C.: National Highway Traffic Safety Administration, 2006).
30. Transportation Research Board Geometric Design Committee and Operational Effects of Geometrics Committee, *Transportation Research Circular Number E-C110. Geometric Design Strategic Research* (Washington, D.C.: Transportation Research Board, 2007).
31. C.V. Zegeer, J. Stutts, H. Huang, M.J. Cynecki, R. Van Houten, B. Alberson, R. Pfefer, T.R. Neuman, K.L. Slack, and K.K. Hardy, *Guidance for Implementation of the AASHTO Strategic Highway Safety Plan. Volume 10: A Guide for Reducing Collisions Involving Pedestrians*, NCHRP Report 500 (Washington, D.C.: National Cooperative Highway Research Program, Transportation Research Board, 2004).
32. International Walk to School official website (Internet) (accessed January, 2009), <http://www.iwalktoschool.org/>.
33. B.F. Herms, 'Pedestrian Crosswalk Study: Accidents in Painted and Unpainted Crosswalks,' *Highway Research Record*, Issue 406 (1972), pp. 1-13.

34. A.R. Gibby, J.L. Stites, G.S. Thurgood, and T.C. Ferrara, *Evaluation of Marked and Unmarked Crosswalks at Intersections in California. Final Report*. Report Number FHWA/CA/TO-94/1 (Sacramento, CA: California Department of Transportation, 1994).
35. T. Koepsell, L. McCloskey, M. Wolf, A.V. Moudon, D. Buchner, J. Kraus, and M. Patterson, 'Crosswalk Markings and the Risk of Pedestrian-Motor Vehicle Collisions in Older Pedestrians,' *Journal of the American Medical Association*, vol. 288, no. 17 (2002), pp. 2136-2143.
36. T.L. Jones and P. Tomcheck, 'Pedestrian Accidents in Marked and Unmarked Crosswalks: A Quantitative Study,' *ITE Journal*, vol. 70, no. 9 (2000), pp. 42-46.
37. J.W. Sparks and M.J. Cynecki, 'Pedestrian Warning Flashers in an Urban Environment: Do They Help?' *ITE Journal*, vol. 60, no. 1 (1990), pp. 32-36.
38. Center for Urban Transportation Research, *Making Crosswalks Safer for Pedestrians. Application of a Multidisciplinary Approach to Improve Pedestrian Safety at Crosswalks in St. Petersburg, Florida* (Tampa, FL: University of South Florida College of Engineering, 2000).
39. G. Somasundaram, C. Hammond, T.J. Smith, and N. Papanikolopoulos, 'A Vision-Based System for Studying the Efficacy of Pedestrian Crosswalk Warnings.' Poster Presentation, University of Minnesota Center for Transportation Studies Nineteenth Annual Transportation Research Conference (Saint Paul, MN, May 20, 2008).
40. O. Masoud and N. Papanikolopoulos, 'Using geometric primitives to calibrate traffic scenes.' In Proceedings of the 2004 IEEE/RJS International Conference on Intelligent Robots and Systems, vol. 2 (2004), pp. 1878– 1883.
41. SPSS Inc., *SPSS Advanced Statistics 7.5* (Chicago, IL: SPSS Inc., 1997).
42. M.F. Mitman and D.R. Ragland, D.R., 'Crosswalk confusion. More evidence why pedestrian and driver knowledge of the vehicle code should not be assumed,' *Transportation Research Record*, vol. 2002 (2007), pp. 55-63

## **Appendix A**

### **Location of Uncontrolled Crosswalk Sites in the Twin Cities Metropolitan Area from Which Data Were Collected**



Figure A-1. Map of Twin Cities metropolitan area showing location of acceptable data crosswalk sites from which data were collected (★ - passive crosswalk warning sites; (☆ active crosswalk warning sites). (Google Maps)

## **Appendix B**

### **Photographs of the 18 Acceptable Data Crosswalk Sites**

This appendix contains photographs of each of the 18 acceptable data sites. The sequential order of site photographs presented is identical to the sequential order of sites listed in the table below.

<b>Site</b>	<b>Observation Date</b>	<b>Crosswalk Warning Type</b>	<b>Crosswalk Location (see Chap. 2, Table 2)</b>
1	7/16/2007	Passive	Roseville - County Road C and Galtier St.
2	7/20/2007	Passive	St. Paul - Arlington Ave. near Trout Brook Circle
3	7/25/2007	Passive	St. Paul - Gateway State Trail across Arlington Ave.
4	8/3/2007	Passive	UM East Bank Campus - Pillsbury Dr.
5	8/6/2007	Passive	Inver Grove Heights - Blaine Ave.
6	8/15/2007	Passive	Roseville - County Road B
7	10/24/2007	Passive	St. Paul - John Ireland Blvd.
8	10/29/2007	Passive	Minneapolis - Godfrey Parkway
9	11/12/2007	Passive	Woodbury - Lake Road
10	7/5/2007	Continuously Active	Minneapolis - 28 <sup>th</sup> Avenue South
11	7/13/2007	Continuously Active	St. Paul - University Ave. at Capitol Blvd.
12	10/22/2007	Continuously Active	Coon Rapids - Northdale Blvd.
13	7/6/2007	Pedestrian-Actuated	Minneapolis - East Minnehaha Parkway
14	7/9/2007	Pedestrian-Actuated	St. Paul - Rice St.
15	8/8/2007	Pedestrian-Actuated	Woodbury - Interlachen Parkway
16	8/10/2007	Pedestrian-Actuated	Minneapolis - West River Parkway
17	8/13/2007	Pedestrian-Actuated	Roseville - Lexington Ave.
18	8/17/2007	Pedestrian-Actuated	Roseville - Dale St.



Figure B-1. Site 1 (see table above). Passive warning crosswalk in Roseville across County Road C at Galtier St., looking west.



Figure B-2. Site 2 (see table above). Passive warning crosswalk in St. Paul across Arlington Ave., looking east.



Figure B-3. Site 3 (see table above). Passive warning Gateway State Trail crosswalk in St. Paul across Arlington Ave., looking west.



Figure B-4. Site 4 (see table above). Passive warning crosswalk in Minneapolis, UM East Bank Campus, across Pillsbury Dr., looking east.



Figure B-5. Site 5 (see table above). Passive warning crosswalk in Inver Grove Heights across Blaine Ave., looking south.



Figure B-6. Site 6 (see table above). Passive warning crosswalk in Roseville across County Road B, looking east.



Figure B-7. Site 7 (see table above). Passive warning crosswalk in St. Paul across eastbound lanes of John Ireland Blvd., looking east.



Figure B-8. Site 8 (see table above). Passive warning crosswalk in Minneapolis across Godfrey Parkway in Minnehaha Park, looking east.



Figure B-9. Site 9 (see table above). Passive warning crosswalk in Woodbury across Lake Rd., looking east.



Figure B-10. Site 10 (see table above). Continuously active warning crosswalk in Minneapolis across 28<sup>th</sup> Ave. South, looking south.



Figure B-11. Site 11 (see table above). Continuously active warning crosswalk in St. Paul across University Ave., looking west.



Figure B-12. Site 12 (see table above). Continuously active warning crosswalk in Coon Rapids across Northdale Blvd., looking east.



Figure B-13. Site 13 (see table above). Pedestrian-actuated warning crosswalk in Minneapolis across East Minnehaha Parkway, looking east.



Figure B-14. Site 14 (see table above). Pedestrian-actuated warning crosswalk in St. Paul across Rice St., looking south.



Figure B-15. Site 15 (see table above). Pedestrian-actuated warning crosswalk in Woodbury across Interlachen Parkway, looking south.



Figure B-16. Site 16 (see table above). Pedestrian-actuated warning crosswalk in Minneapolis across West River Parkway, looking east.



Figure B-17. Site 17 (see table above). Pedestrian-actuated warning crosswalk in Roseville across Lexington Ave., looking south.



Figure B-18. Site 18 (see table above). Pedestrian-actuated warning crosswalk in Roseville across Dale St., looking south.

## **Appendix C**

### **Component List for Camera Boom Traffic Monitoring System**

## **Component Parts List for Camera Boom Traffic Monitoring System**

Laptop computer - Toshiba Satellite Model M115 S3094  
RCA extension cable (Model QS60F)

4 channel USB 2.0 DVR (QSEE Model QSU2DVR04)

Xantrex power inverter (400+) (12V to 110V inverter)

Cameras- (2) Elmo tsn401a with wide angle lenses

PTZ-1000; Joystick style variable speed pan-and-tilt camera mount (CSA-4019)

Camera power supply- (2) Radio Shack multi-voltage 1.5-12V DC/300mA regulated AC-to-DC adapter (Model: 273-1662)

12V car battery

### **Various Parts and Wiring**

Ideal Terminal Strip (#89-408)

Spade connectors for block

Shrink-wrap tubing

2" Step Bumper Hitch mount (Buyers PC model #SBH2)

Mounting bolts and hardware

7/16ths" drill bit (for mount holes)

10½" conduit and clamps

Mounting plates and hardware for roof mounts on vehicle.

Tube clamp gate hardware for above and mast.

Nylon zip-ties.

High reflectivity safety tape.

Friction tape

Power strip

½" pipe insulation foam (for cables)

## **Appendix D**

### **Flow Chart and Description of Software Platform**

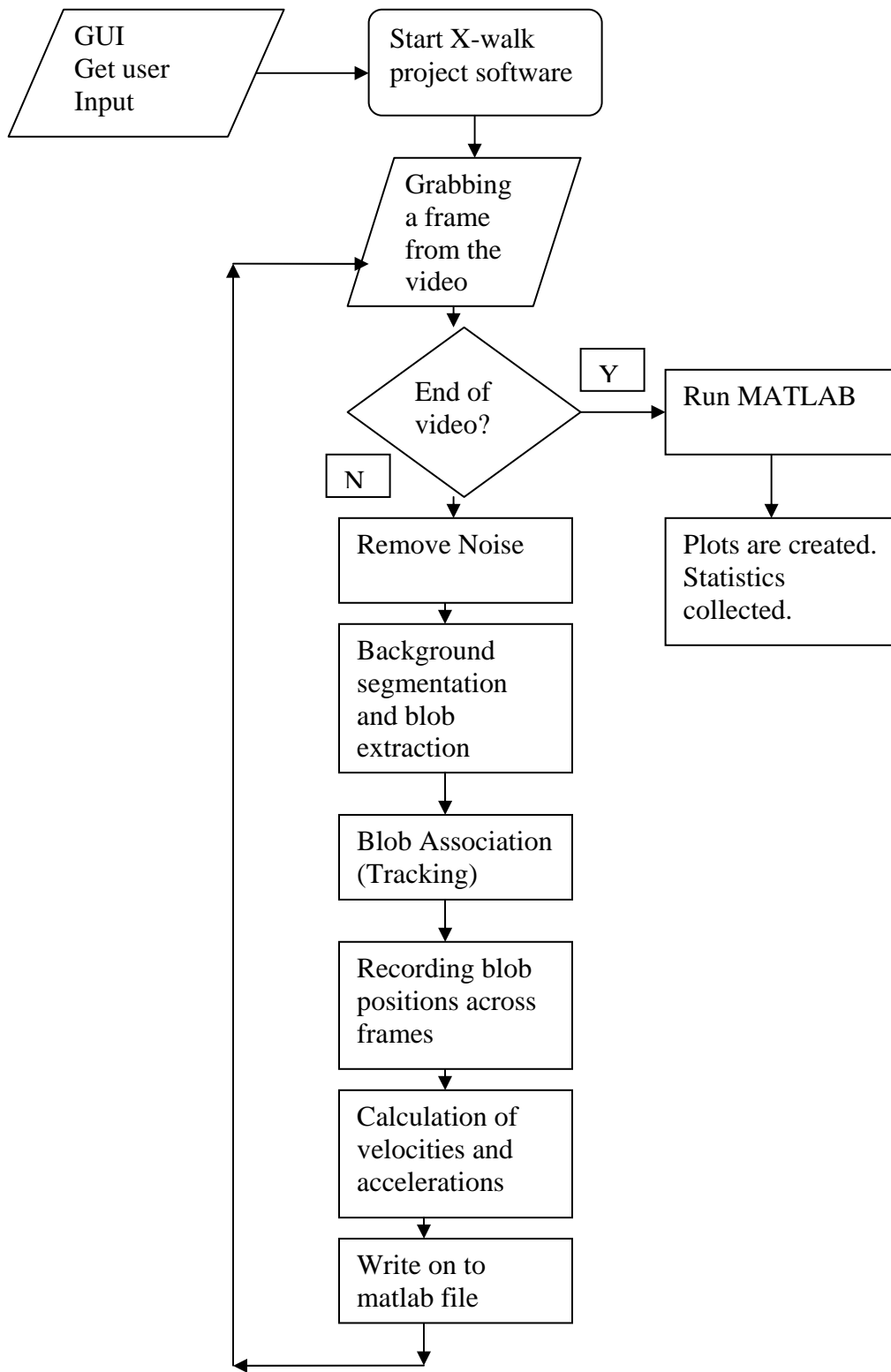

Figure D-1. Flow chart for software platform.

## Description of the Software Platform

### Introduction

The software platform was developed and run in Linux for purposes of convenience. However, all the tools used are cross-platform and can be ported to be executable in Windows systems as well. The libraries this software requires for operation are VXL version 1.5, and OpenCV version 1.0, which are free and available online for download. These libraries are also cross-platform and porting code to Windows systems is straightforward. This software generates some Matlab code for analysis of the collected statistics; hence, Matlab is required to view the output of the code, which is a set of plots. The reason for choosing Matlab is that the plots can be customized and the data-set can be treated for spurious data.

### The GUI

The GUI (graphical user interface) was built using Qt 4.0, an open source GUI editing tool. This development kit is cross-platform and uses standard C++. A binary file is created which is the only important file for this software. The binary code has to be rebuilt any time changes are needed in the GUI. Changes to the GUI can be made at any time if needed. Fig. D-2 is a snapshot of the GUI window.

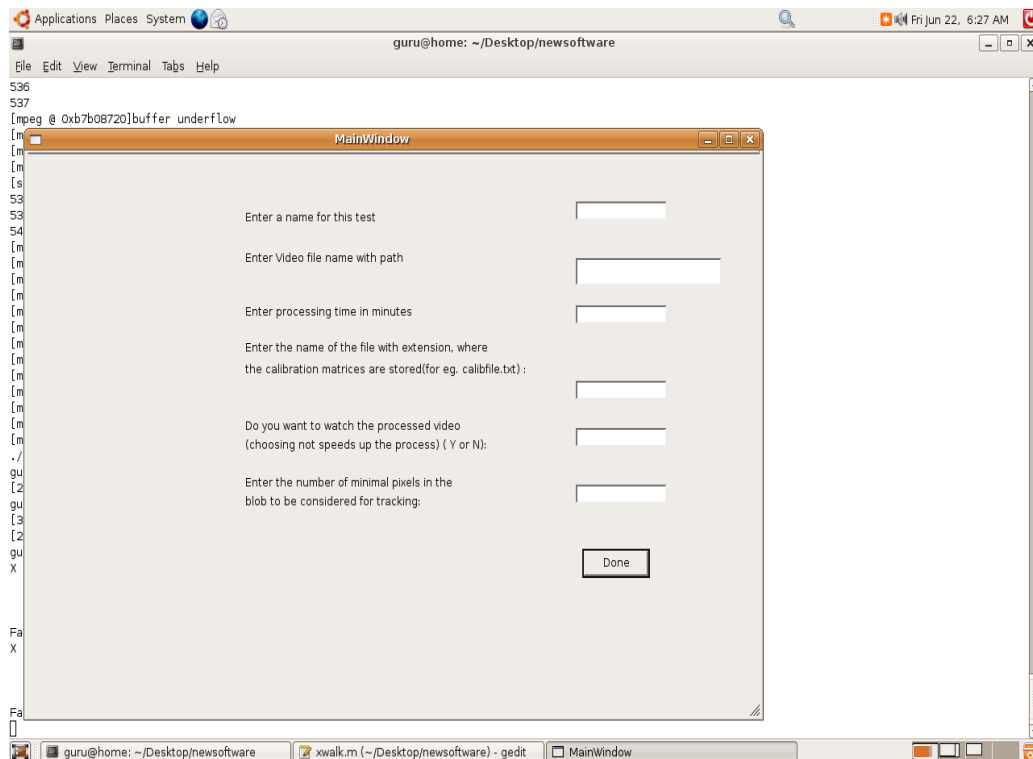

Figure D-2. Snapshot of the GUI.

The GUI collects all user input pertaining to the video being subjected to analysis. Then the actual software is invoked, which uses output from the GUI. The GUI collects the following information from the user:

- A name for the test (Can include crosswalk location and analysis number since multiple analyses can be done)
- Location of the video file in the system
- Time in minutes for which the processing needs to be done
- Location of the file where calibration information for the scene is located
- Whether the user wants to view the processed video
- Finally, a rough idea of the size of a pedestrian in pixels to aid in tracking

### Frame Grabber

The frame grabber is implemented using OpenCV. This code grabs successive frames from the video, prepares them by placing them in a suitable template, and sends it on for processing. This also allows the user to specify where the crosswalk is located in the image, and to specify the region of interest. The file name is frames.cpp.

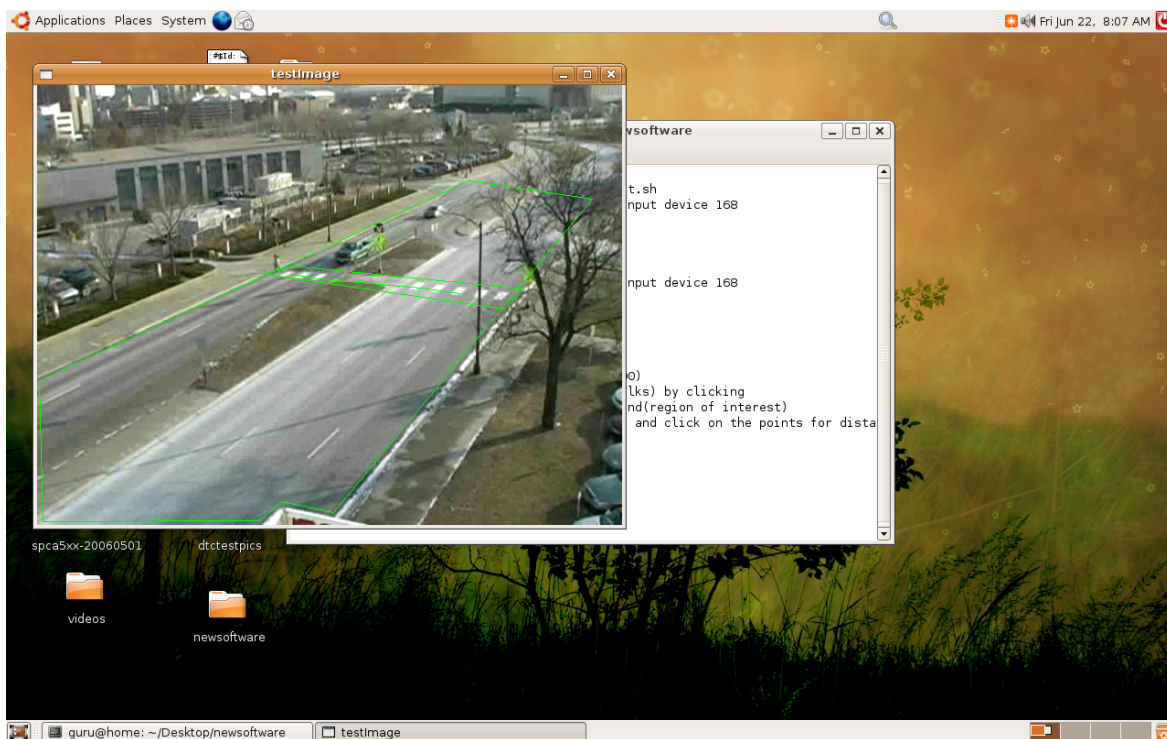

Figure D-3. Specifying the crosswalk location and a region of interest.

### **Core processing control**

This code controls the flow of each frame of the video over various stages of processing. After which it also generates the Matlab file that can be run to create the plots. The filenames are AlgorithmCore.cpp and AlgorithmCore.h.

### **Image De-Noising**

The image can be de-noised using median or wiener filtering for removal of salt and pepper noise and introduction of a Gaussian blur. BGDenoiser.cpp and BGDenoiser.h are filenames associated with this task.

### **Background Segmentation**

The background and foreground pixels are separated using the Mixture of Gaussians technique. Each pixel has a label as to whether it belongs to the foreground or background. Filenames are MixtureBGSegmentation.h and MixtureBGSegmentation.cpp, plus support files.

### **Blob Extraction**

This routine extracts the foreground pixels that are grouped together and are above a size as pedestrians or vehicles, and then sets the rest of the pixels as noise and removes them. This is done using morphological image processing operations. The filenames are RegionExtraction.cpp and RegionExtraction.h.

### **Blob Association**

This code associates the pedestrians and vehicles by maintaining the right identities of the blobs across frames. This uses a bipartite graph bases approach. The filenames associated are BlobTracking.cpp and BlobTracking.h.

### **Point Conversion**

PointConversions.cpp and PointConversions.h help in converting image coordinates to world coordinates using the calibration data.

### **Geometry**

Geometry.cpp and Geometry.h aid in determining if a pedestrian is in the crosswalk and if a vehicle is in the region of interest. This procedure helps in avoiding unnecessary data.

The Matlab file generated at the end is xwalk.m. Two representative plots for data collected at Site 14 (Chap. 2, Table 3, a pedestrian-actuated warning site) are shown below.

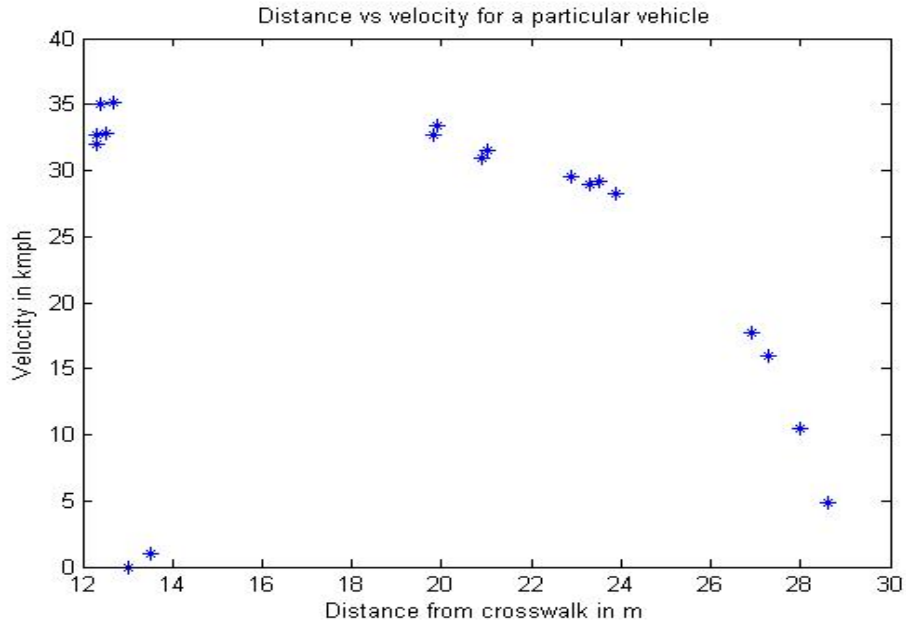

Figure D-4. Distance to crosswalk vs vehicle velocity for one vehicle-crosswalk interaction at Site 14 (Chap. 2, Table 3), with no pedestrian present at the crosswalk.

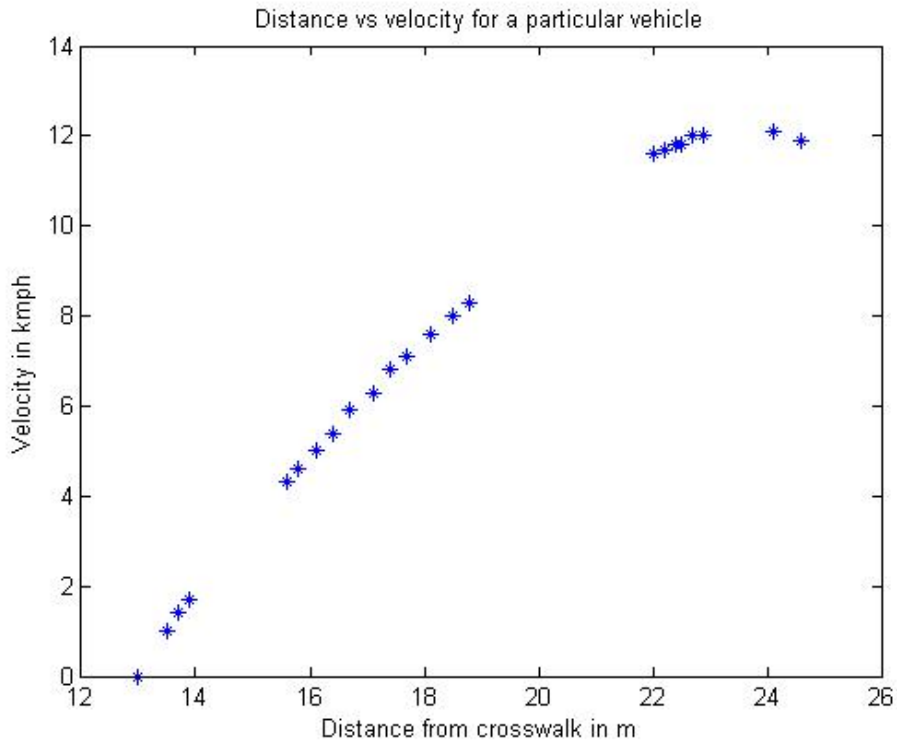

Figure D-5. Distance to crosswalk versus vehicle velocity for one vehicle-crosswalk interaction at Site 14 (Chap. 2, Table 3), with a pedestrian present at the crosswalk.

**Acknowledgements:**

Some sections of the code have been written by two colleagues of Guruprasad Somasundaram at the UM AIRVL, Stefan Atev and Loren Fiore.

## **Appendix E**

### **Photographs of Steps**



Figure E-1. Laying out camera boom components. The black and white banded pole is the calibration stick inserted (temporarily) in the hitch assembly.



Figure E-2. Nesting boom tube elements and judging boom height that will be required for camera viewing of the crosswalk (at this site, the crosswalk is located below the second level of the parking ramp where the observation vehicle is positioned).



Figure E-3. Affixing camera mount platform to apex of camera boom, and preparing cable snake.



Figure E-4. Erecting camera boom after base of boom has been inserted into hitch assembly (photograph taken at different site from the site portrayed in preceding and following photographs).



Figure E-5. Affixing diagonal support rods to camera boom and to luggage rack of observation vehicle.

## **Appendix F**

### **Sample Site Observation Recording Form**

## St. Paul, Rice & Aurora



		<i>Location</i>	<i>Environment</i>	
	Site/City	St. Paul	Weather	Sunny/Wind ~10-14mph
	Address	<b>Rice &amp; Aurora</b>	Terrain	Flat
	Date	<b>07 / 9 /07</b>	Traffic	Mod-Heavy
	Time	3pm -6pm	Controls	Active Ped-Activated      Passive

Cameras: Both Heads @ 24ft/Long  
FL    Some wind shake.

~3 peds. Activate light. (will confirm after film anal.) Changed computers @ 4:10 and 4:20. Peds claim traffic is much worse behaved in around 8-9am. Ped stripes=7'

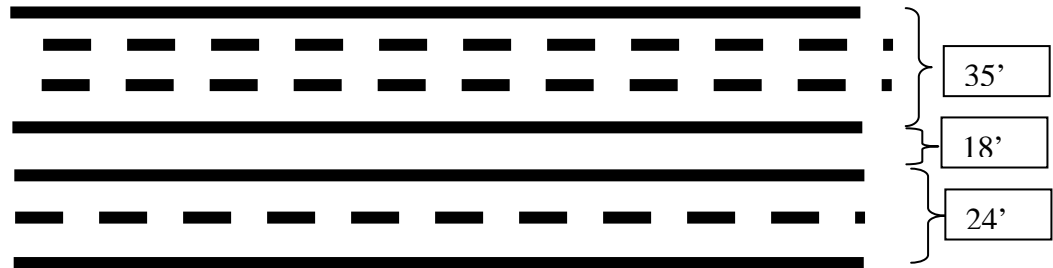

## **Appendix G**

### **Frequency Distributions of Average Vehicle Velocities and Decelerations/Accelerations at Different Distances from the Crosswalk, Relative to Type of Crosswalk Warnin**

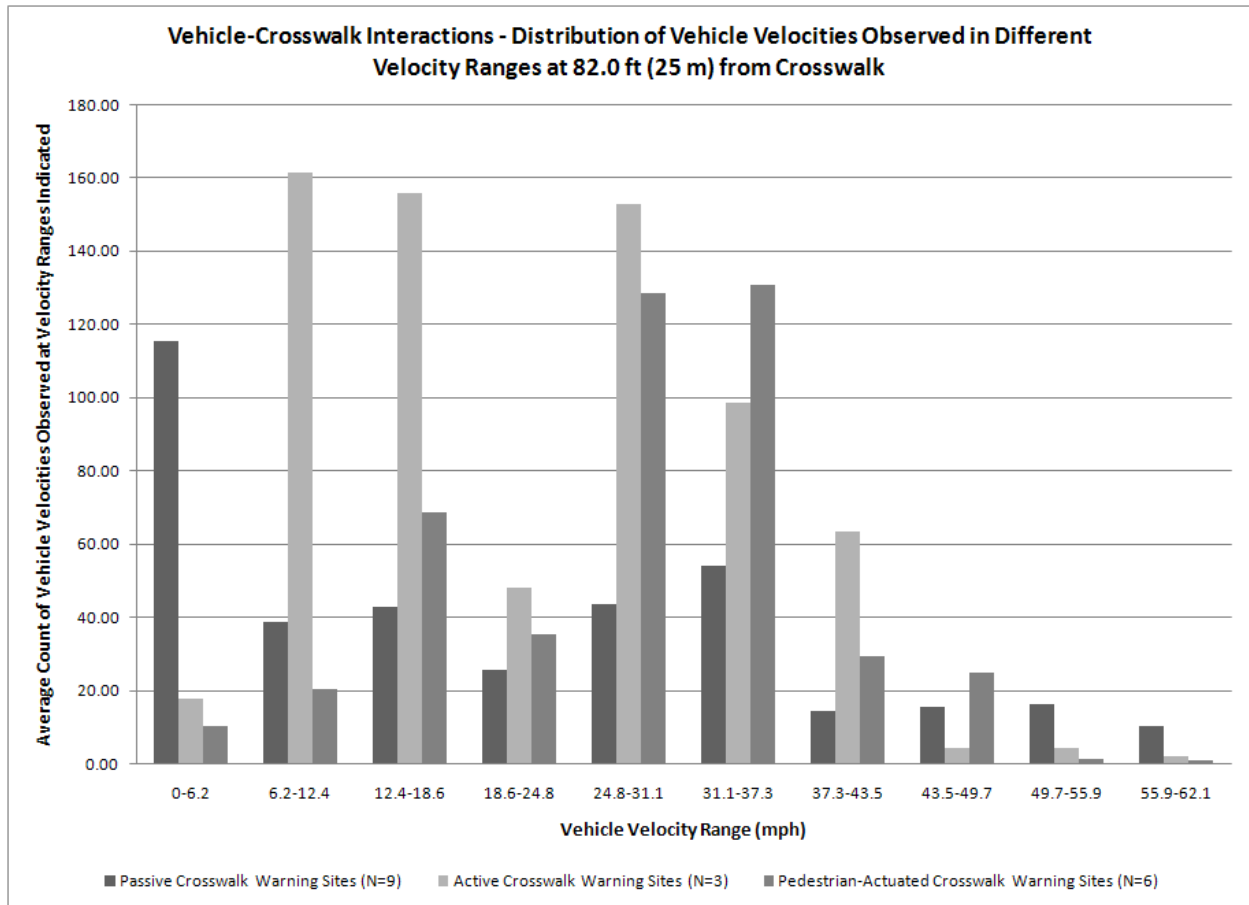

Figure G-1. Distribution of average counts of vehicle velocities observed in different velocity ranges at 82.0 ft (25 m) from crosswalk, for vehicle-crosswalk interactions at passive, active and pedestrian-actuated crosswalk warning sites.

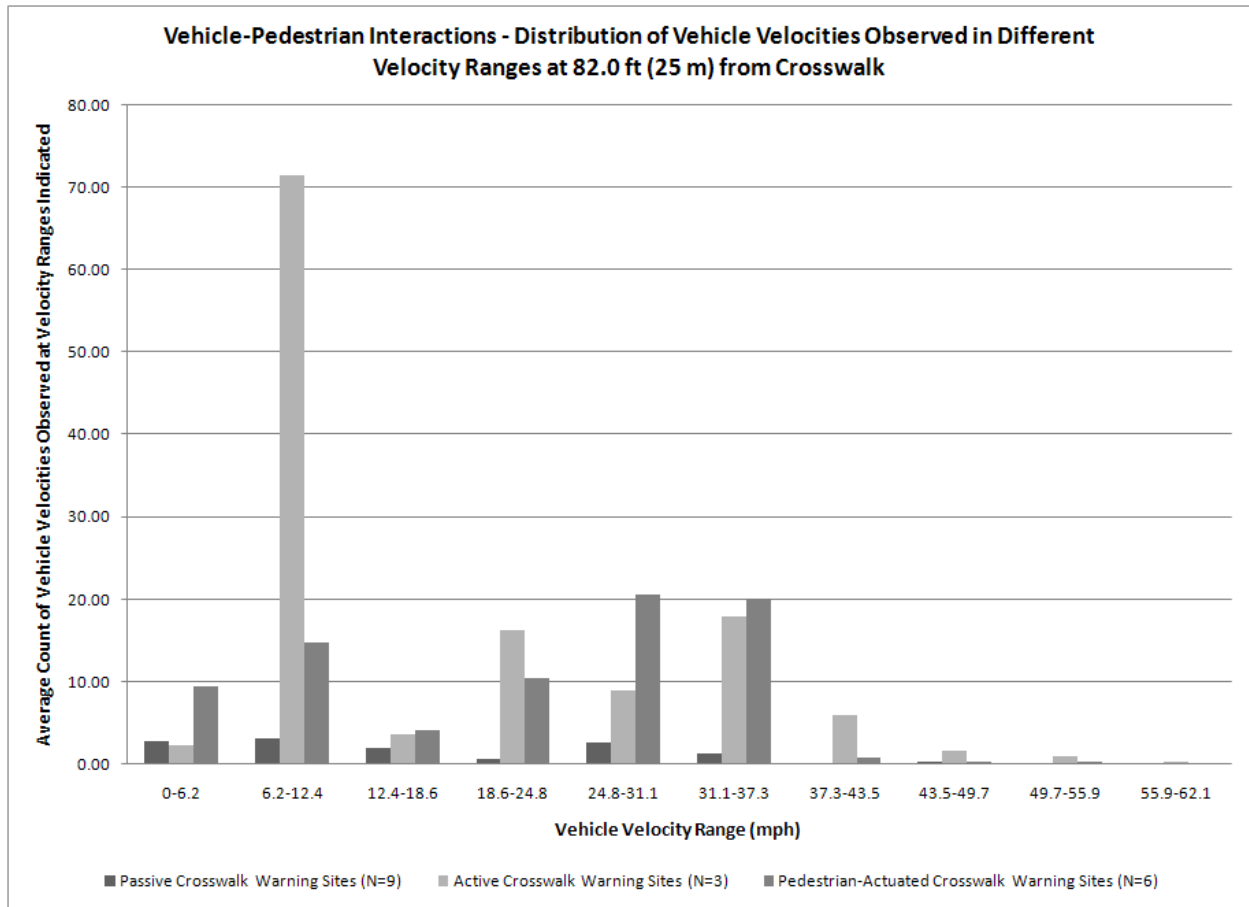

Figure G-2. Distribution of average counts of vehicle velocities observed in different velocity ranges at 82.0 ft (25 m) from crosswalk, for vehicle-pedestrian interactions at passive, active and pedestrian-actuated crosswalk warning sites.

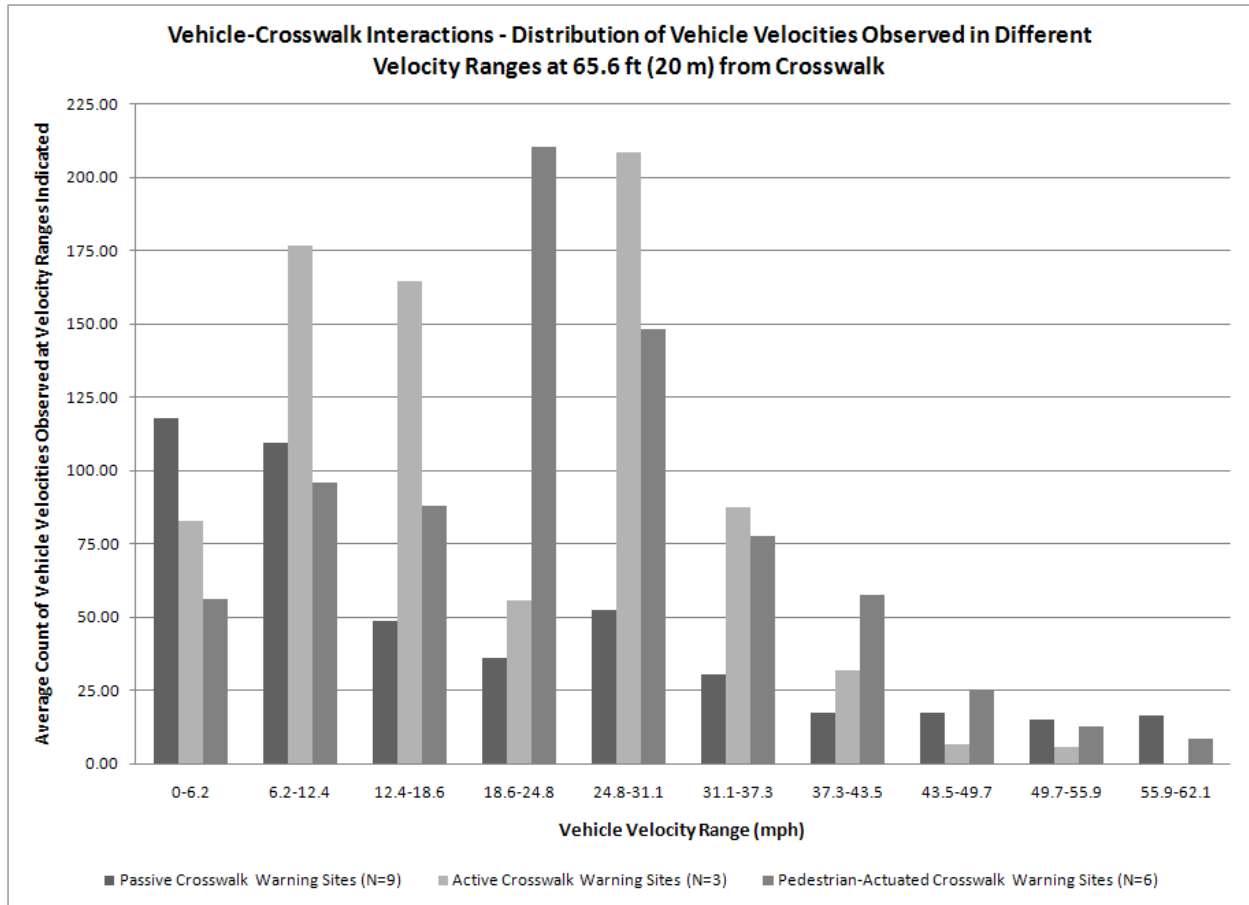

Figure G-3. Distribution of average counts of vehicle velocities observed in different velocity ranges at 65.6 ft (20 m) from crosswalk, for vehicle-crosswalk interactions at passive, active and pedestrian-actuated crosswalk warning sites.

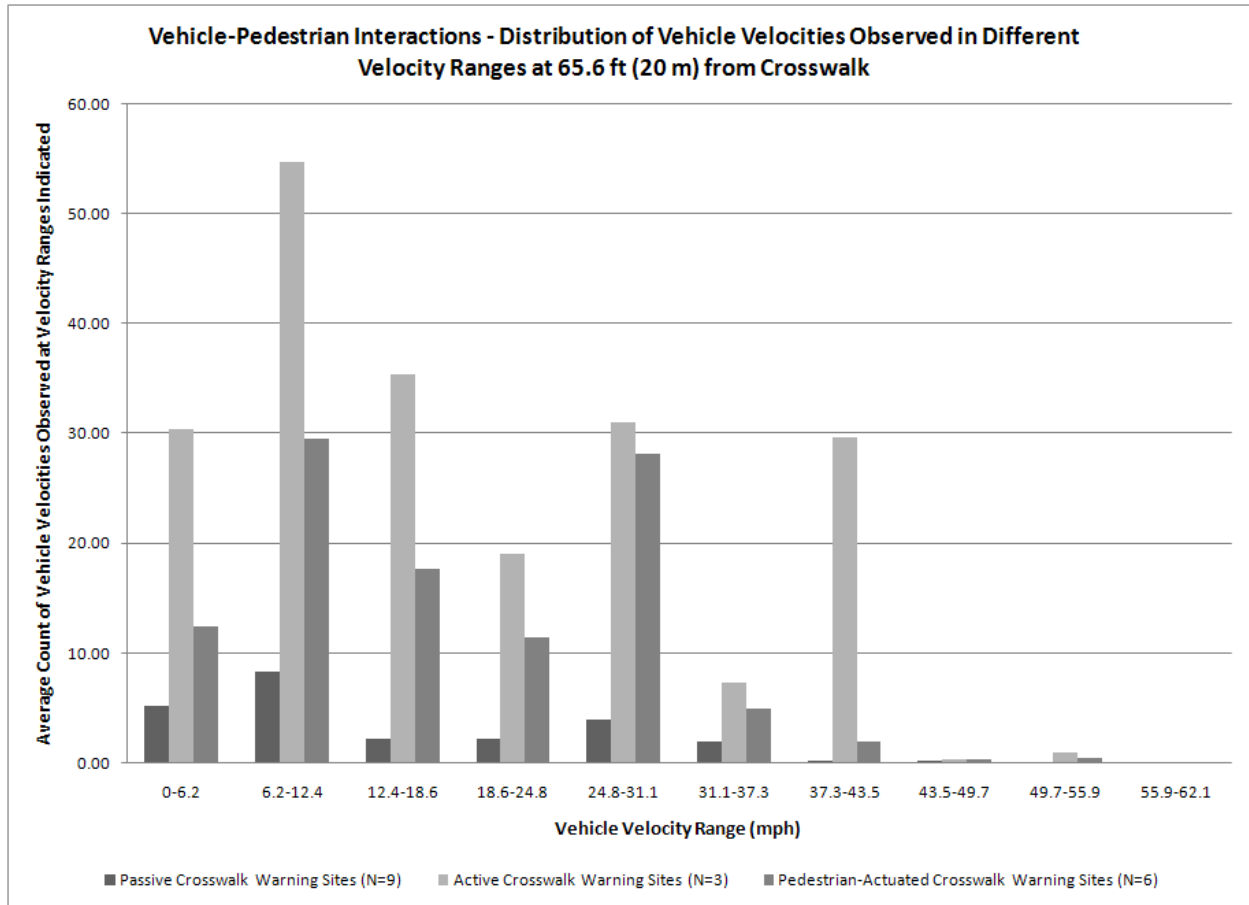

Figure G-4. Distribution of average counts of vehicle velocities observed in different velocity ranges at 65.6 ft (20 m) from crosswalk, for vehicle-pedestrian interactions at passive, active and pedestrian-actuated crosswalk warning sites.

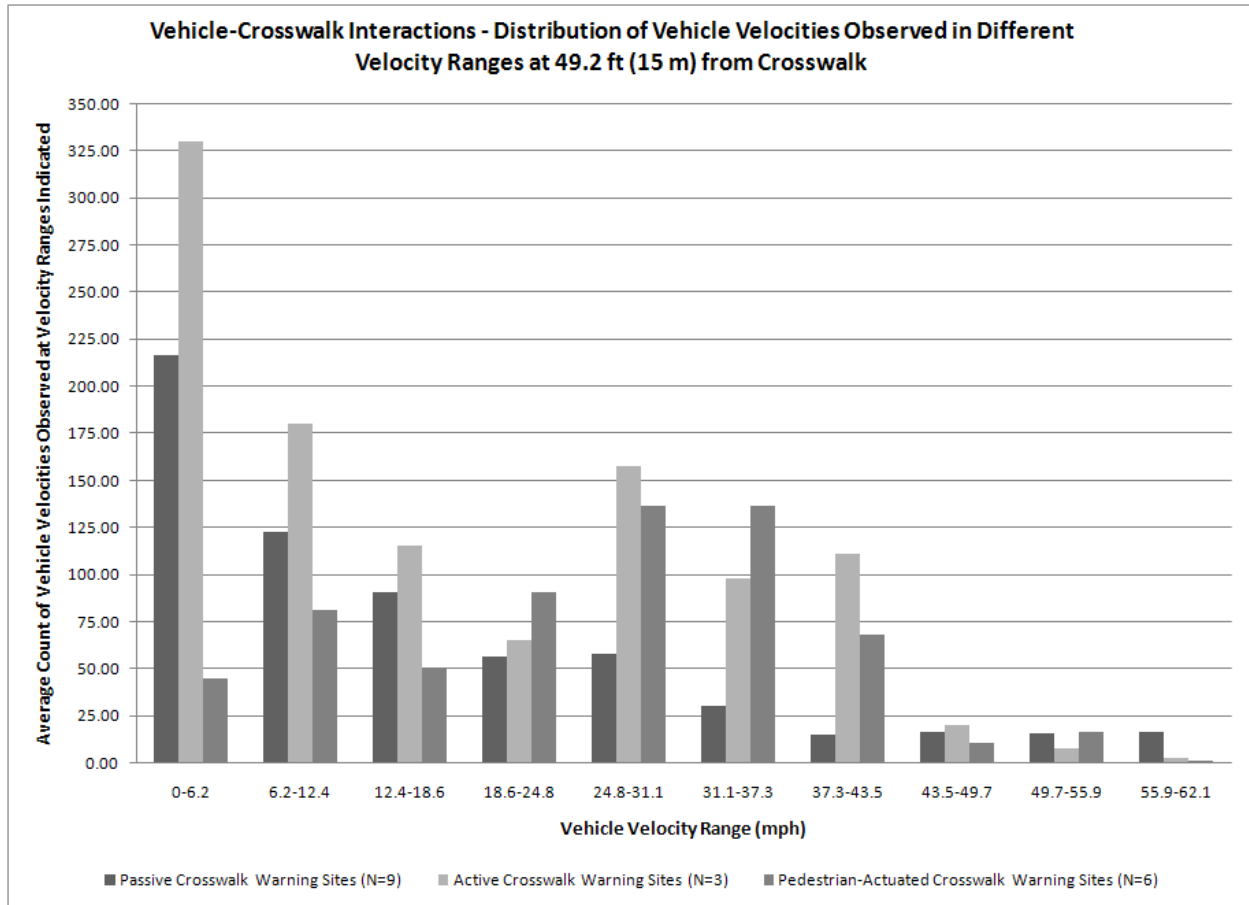

Figure G-5. Distribution of average counts of vehicle velocities observed in different velocity ranges at 49.2 ft (15 m) from crosswalk, for vehicle-crosswalk interactions at passive, active and pedestrian-actuated crosswalk warning sites.

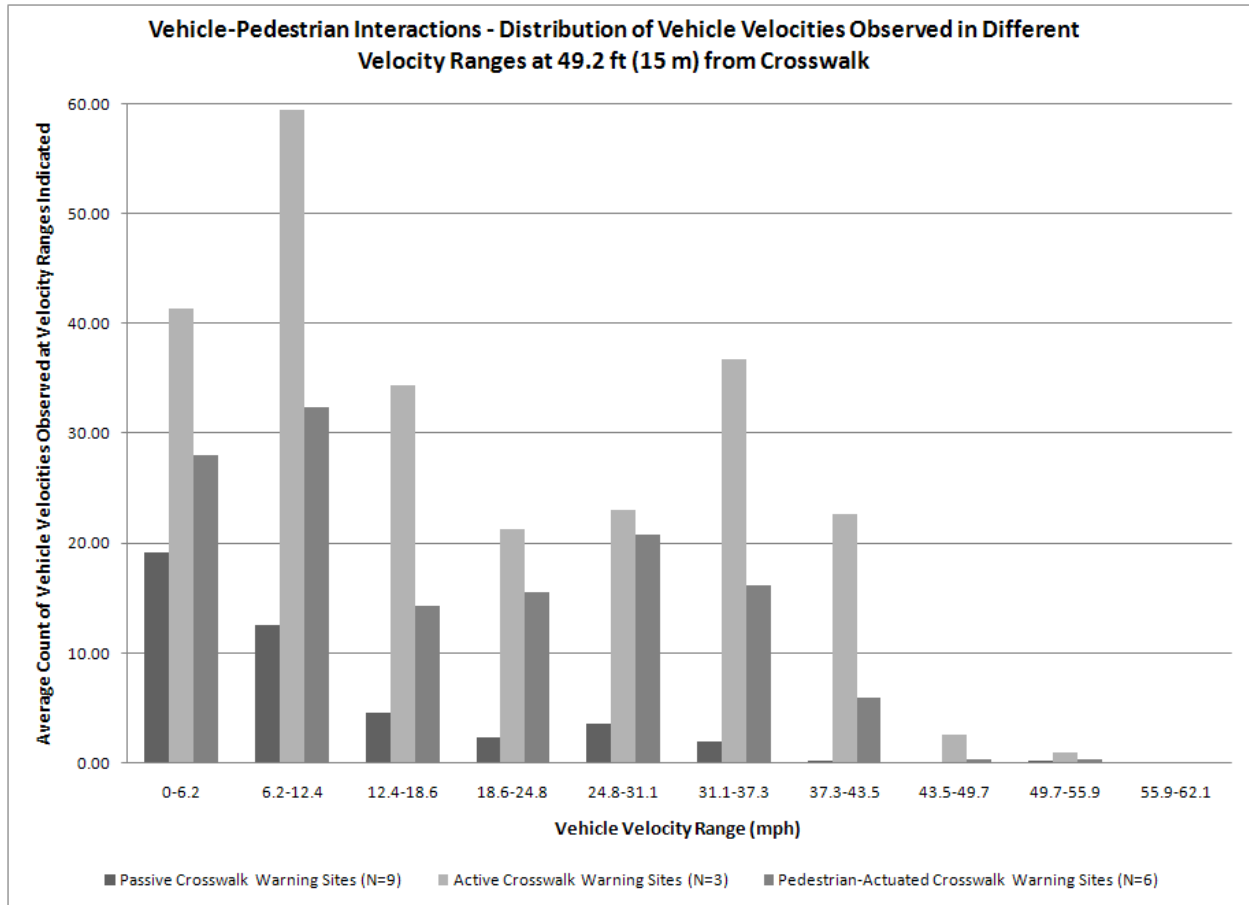

Figure G-6. Distribution of average counts of vehicle velocities observed in different velocity ranges at 49.2 ft (15 m) from crosswalk, for vehicle-pedestrian interactions at passive, active and pedestrian-actuated crosswalk warning sites.

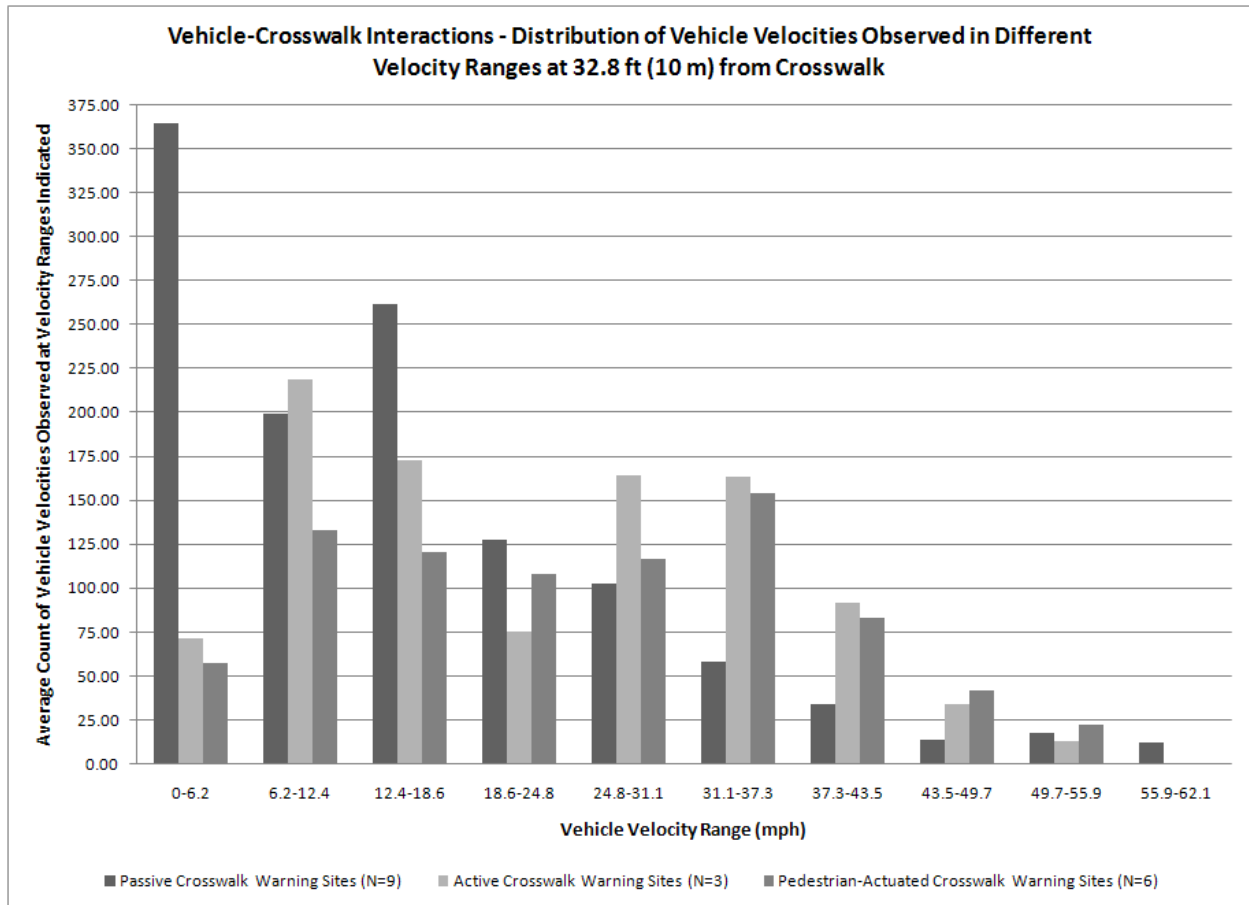

Figure G-7. Distribution of average counts of vehicle velocities observed in different velocity ranges at 32.8 ft (10 m) from crosswalk, for vehicle-crosswalk interactions at passive, active and pedestrian-actuated crosswalk warning sites.

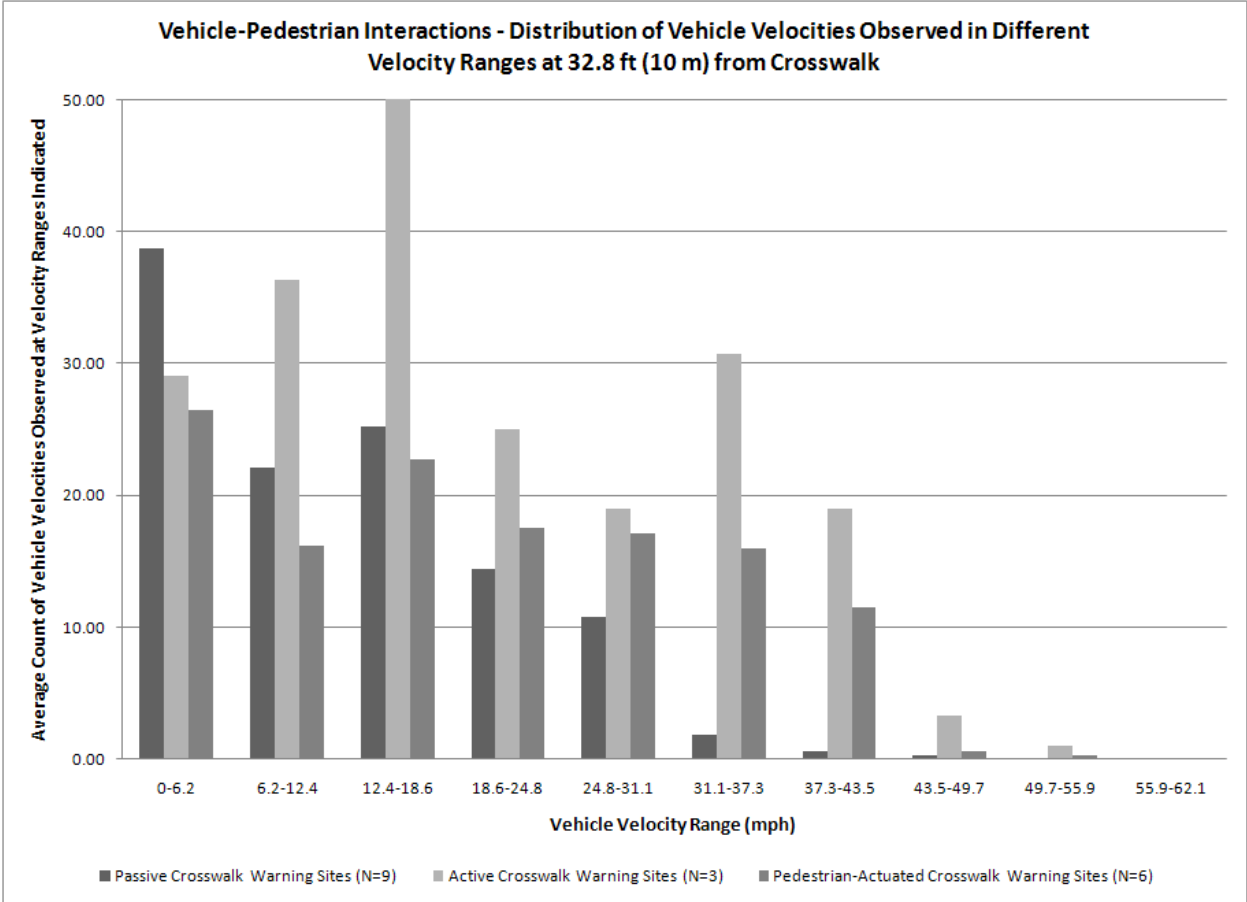

Figure G-8. Distribution of average counts of vehicle velocities observed in different velocity ranges at 32.8 ft (10 m) from crosswalk, for vehicle-pedestrian interactions at passive, active and pedestrian-actuated crosswalk warning sites.

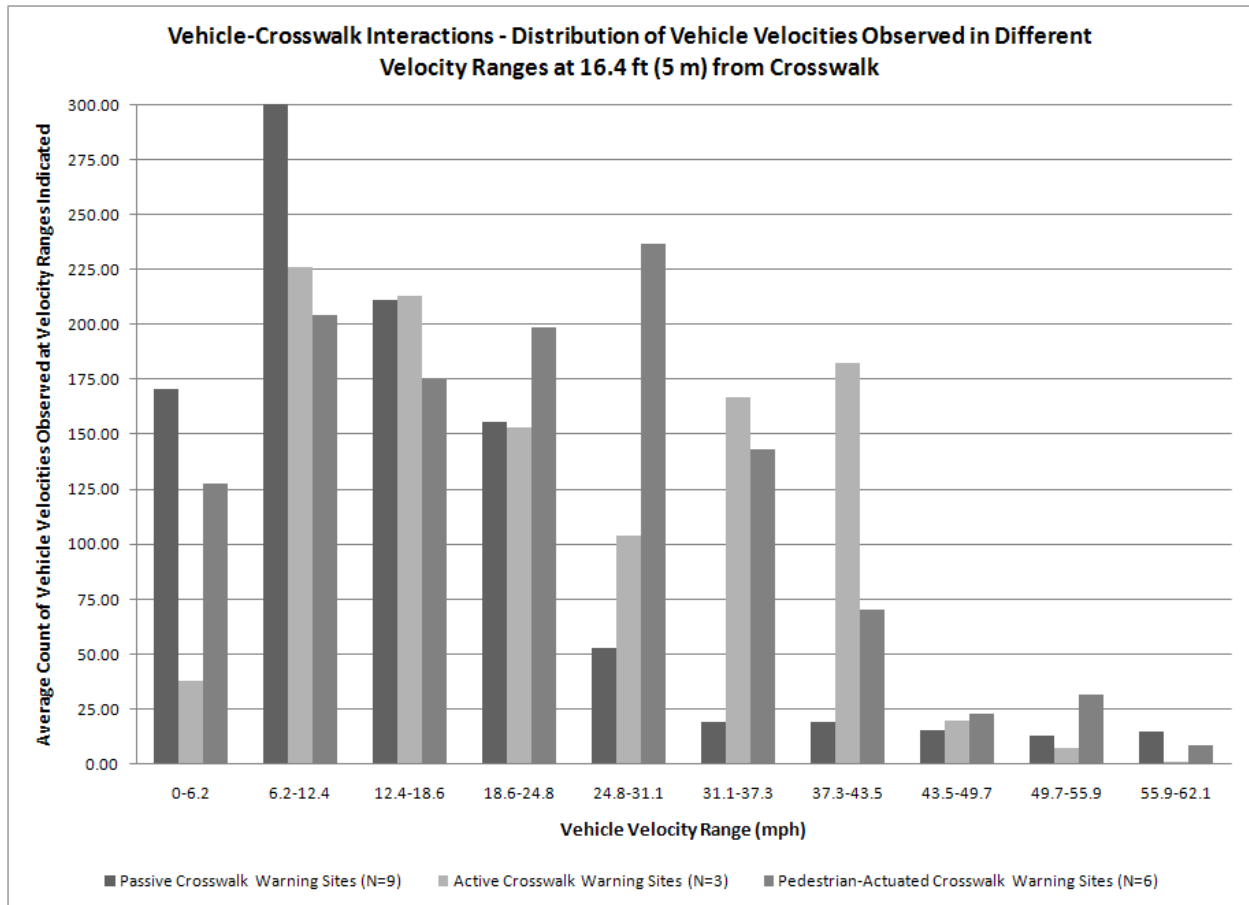

Figure G-9. Distribution of average counts of vehicle velocities observed in different velocity ranges at 16.4 ft (5 m) from crosswalk, for vehicle-crosswalk interactions at passive, active and pedestrian-actuated crosswalk warning sites.

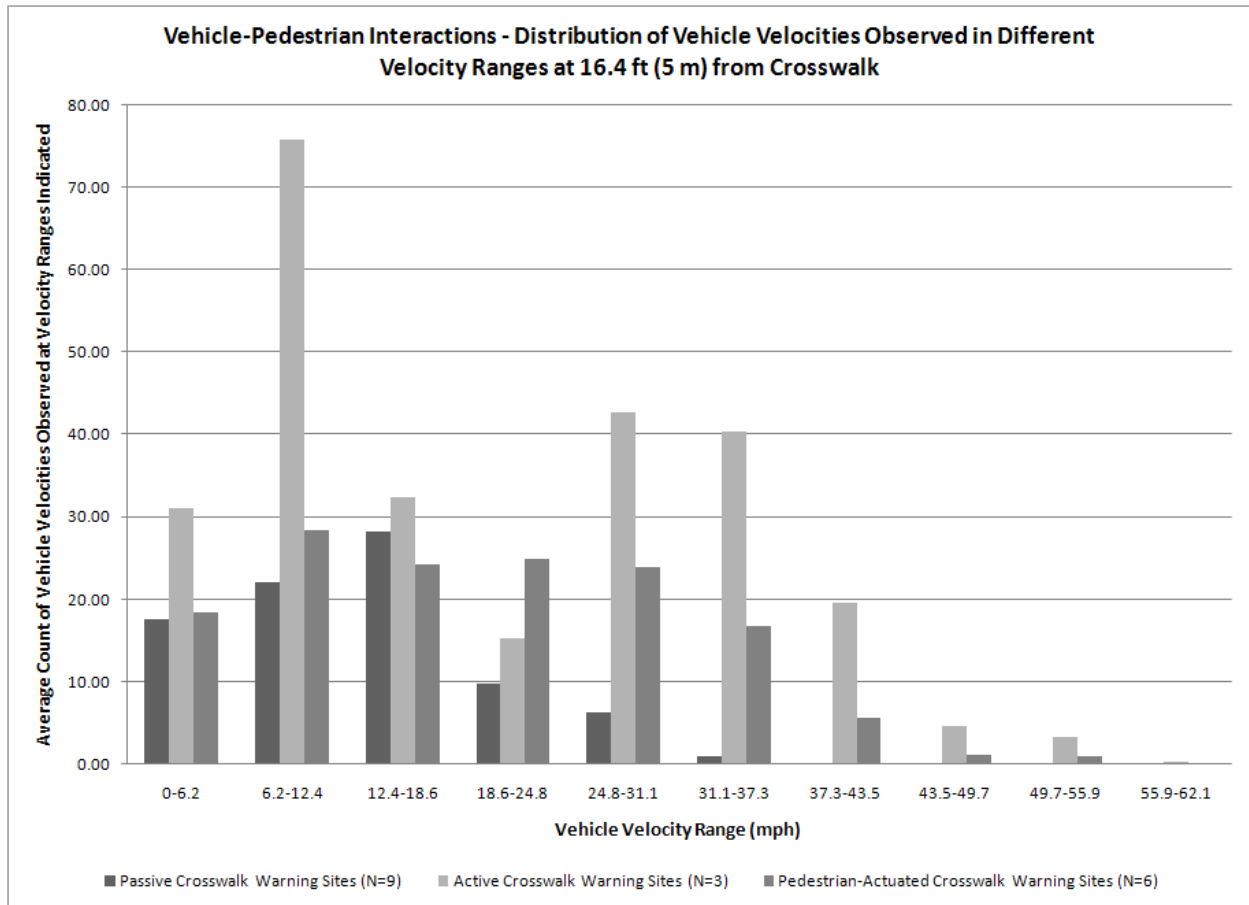

Figure G-10. Distribution of average counts of vehicle velocities observed in different velocity ranges at 16.4 ft (5 m) from crosswalk, for vehicle-pedestrian interactions at passive, active and pedestrian-actuated crosswalk warning sites.

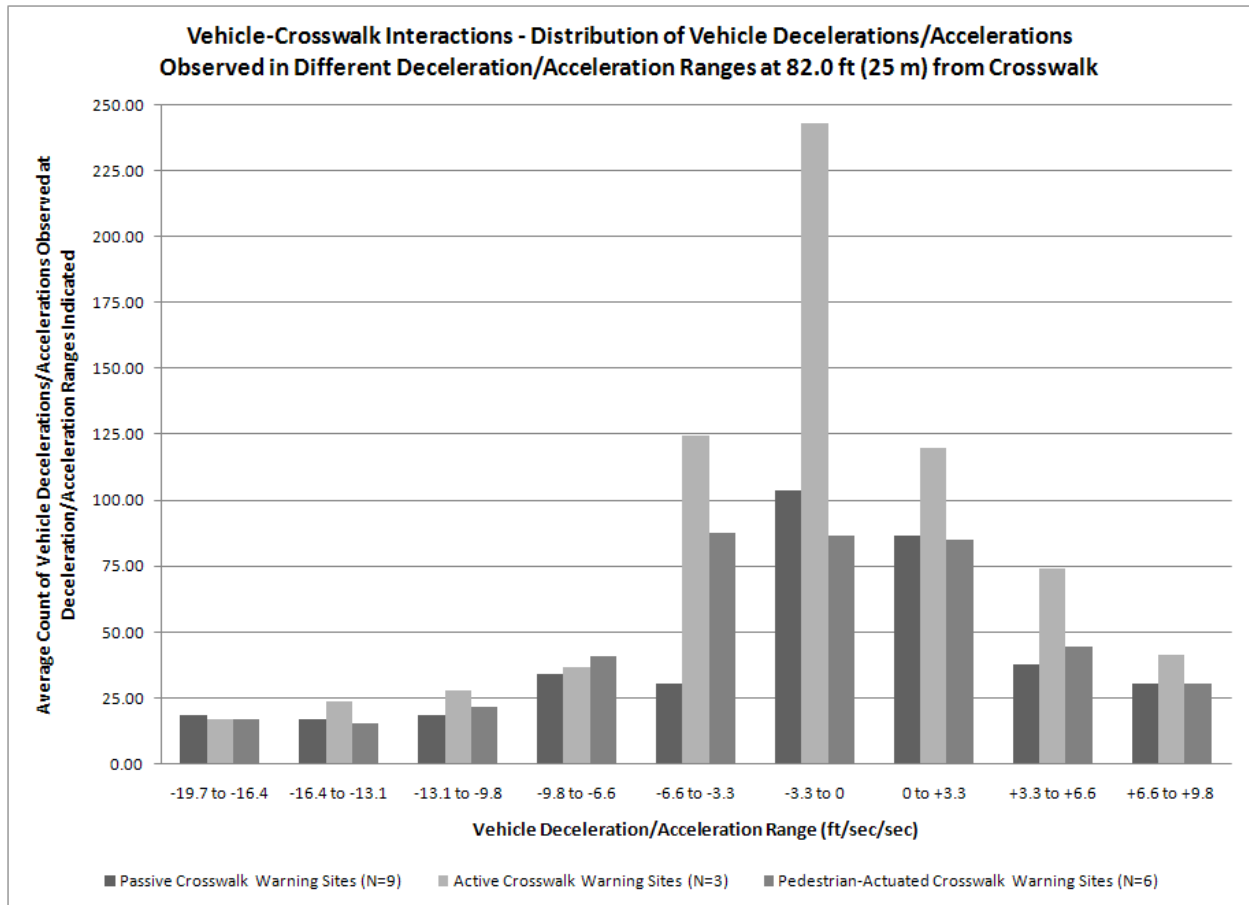

Figure G-11. Distribution of average counts of vehicle decel/accel values observed in different decel/accel ranges at 82.0 ft (25 m) from crosswalk, for vehicle-crosswalk interactions at passive, active and pedestrian-actuated crosswalk warning sites.

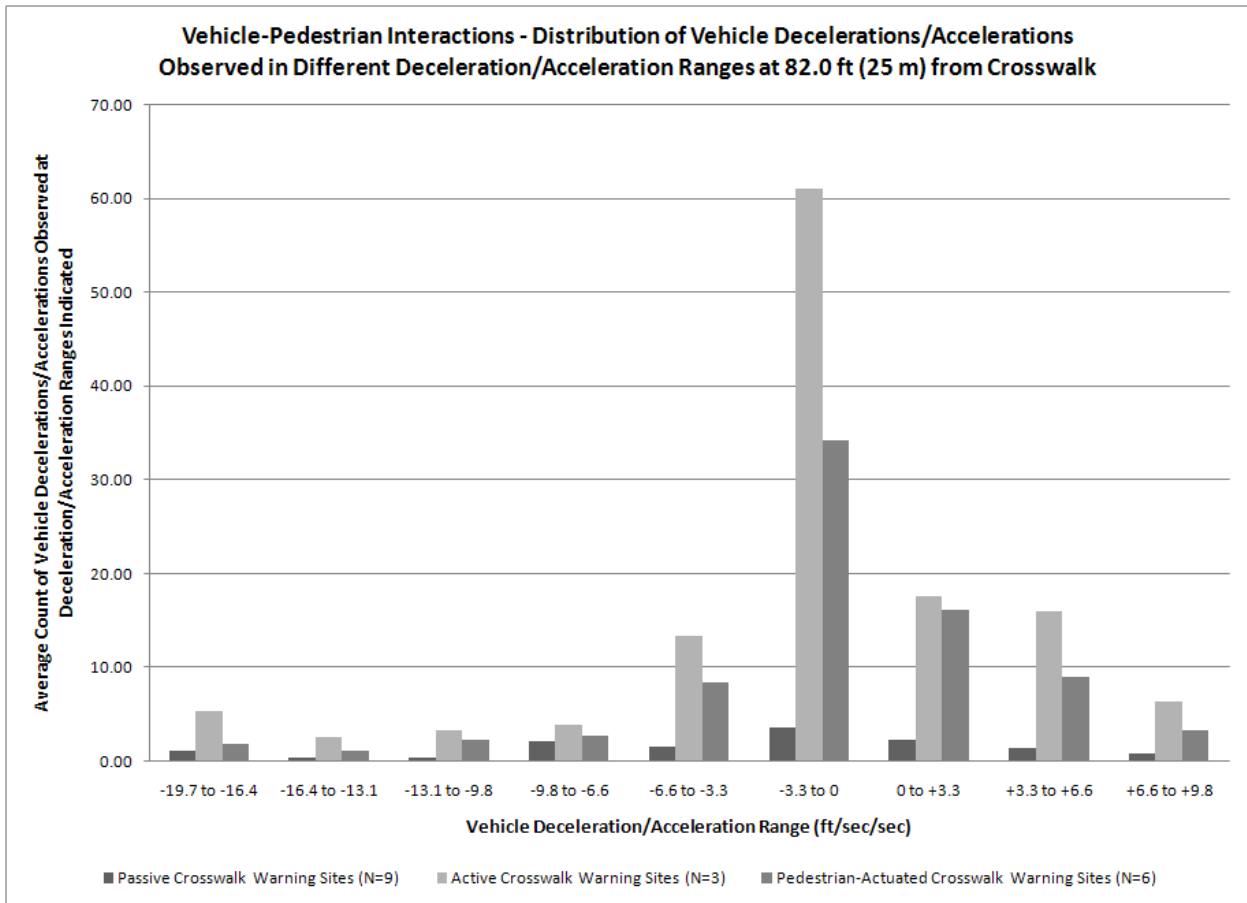

Figure G-12. Distribution of average counts of vehicle decel/accel values observed in different decel/accel ranges at 82.0 ft (25 m) from crosswalk, for vehicle-pedestrian interactions at passive, active and pedestrian-actuated crosswalk warning sites.

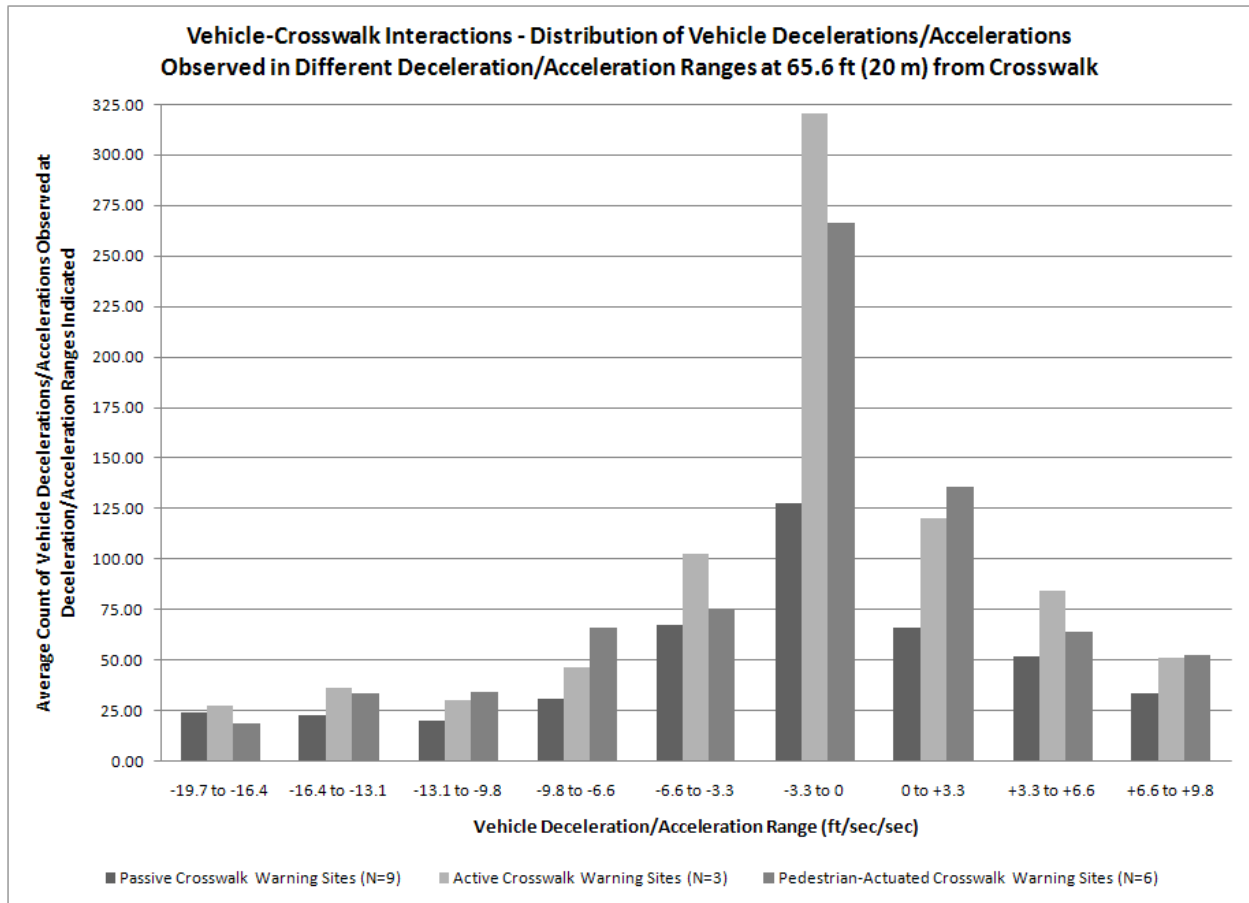

Figure G-13. Distribution of average counts of vehicle decel/accel values observed in different decel/accel ranges at 65.6 ft (20 m) from crosswalk, for vehicle-crosswalk interactions at passive, active and pedestrian-actuated crosswalk warning sites.

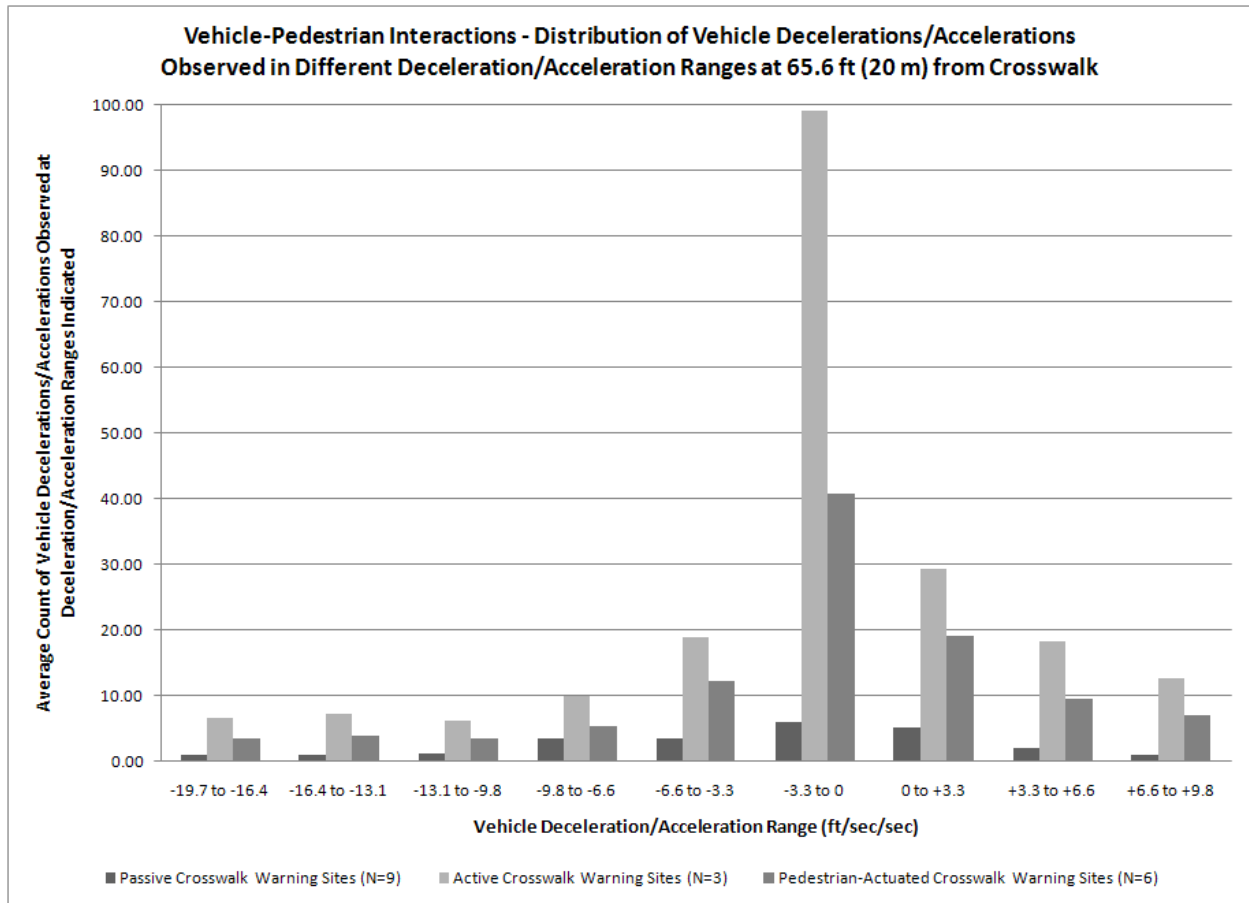

Figure G-14. Distribution of average counts of vehicle decel/accel values observed in different decel/accel ranges at 65.6 ft (20 m) from crosswalk, for vehicle-pedestrian interactions at passive, active and pedestrian-actuated crosswalk warning sites.

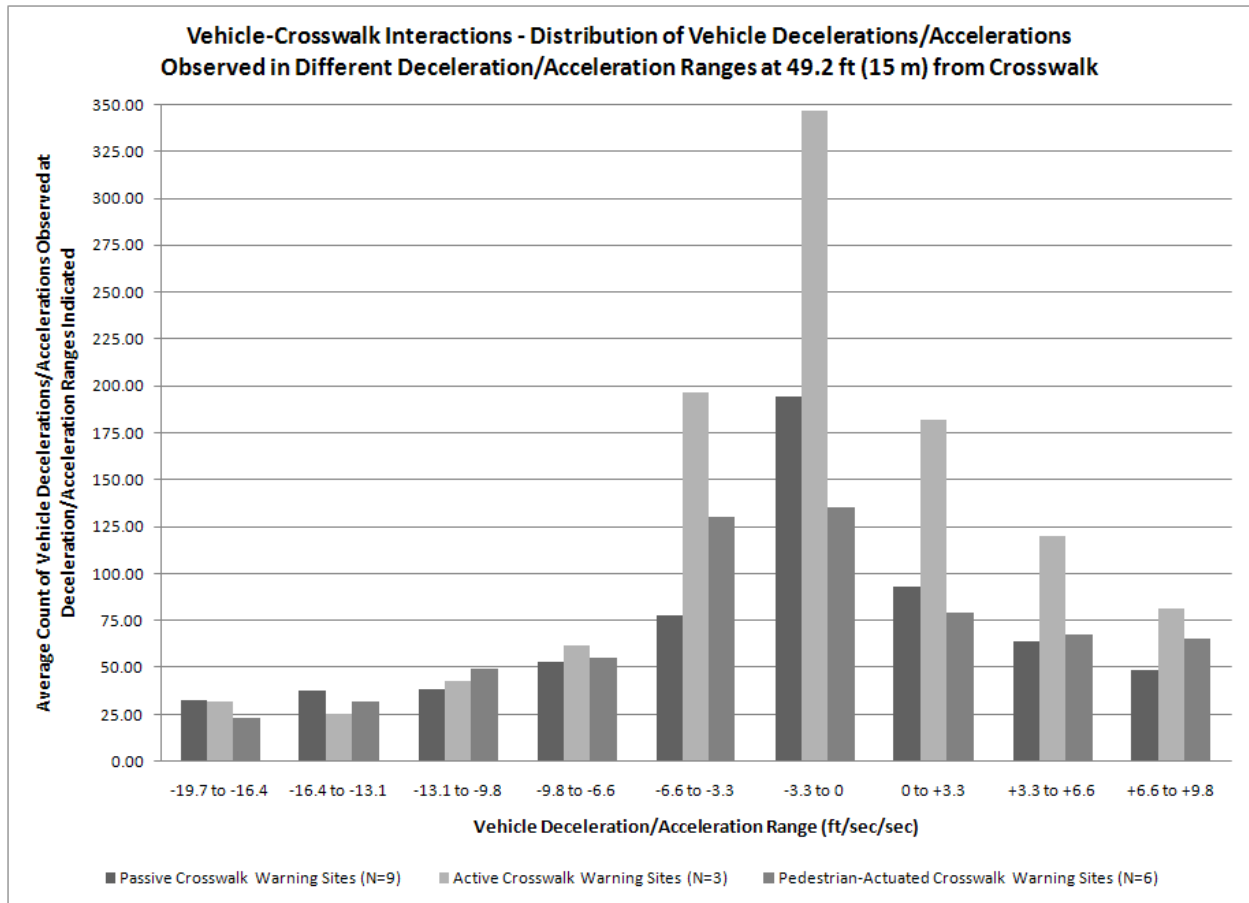

Figure G-15. Distribution of average counts of vehicle decel/accel values observed in different decel/accel ranges at 49.2 ft (15 m) from crosswalk, for vehicle-crosswalk interactions at passive, active and pedestrian-actuated crosswalk warning sites.

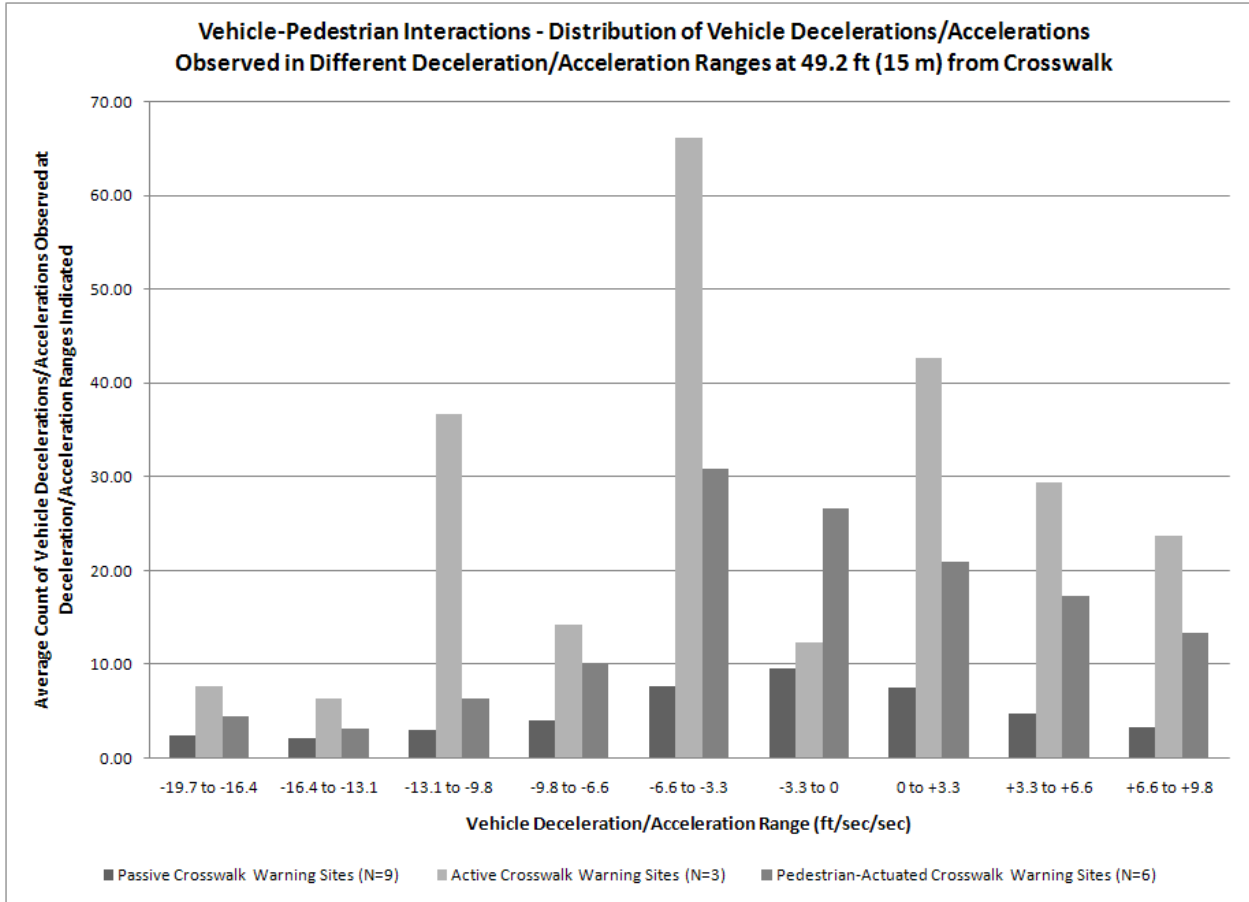

Figure G-16. Distribution of average counts of vehicle decel/accel values observed in different decel/accel ranges at 49.2 ft (15 m) from crosswalk, for vehicle-pedestrian interactions at passive, active and pedestrian-actuated crosswalk warning sites.

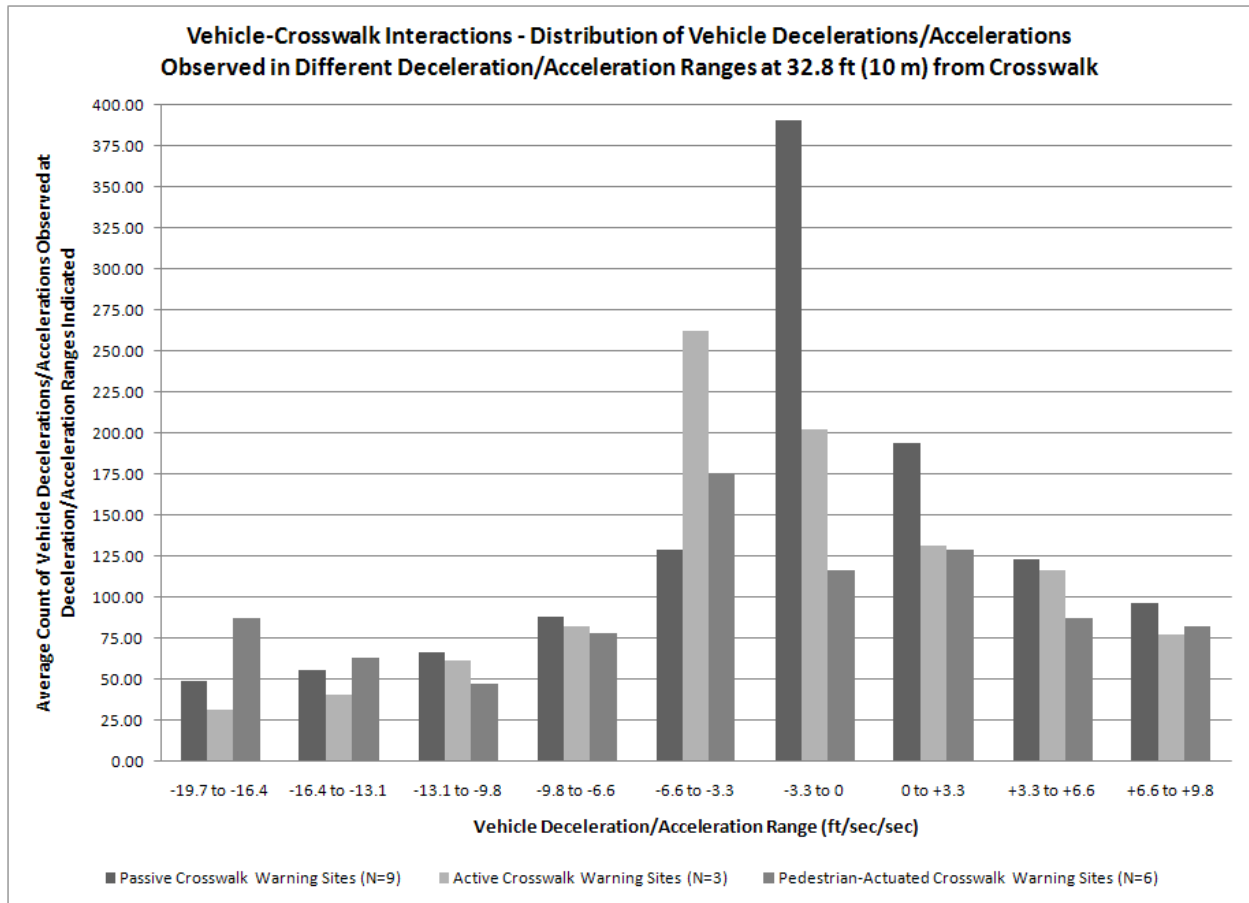

Figure G-17. Distribution of average counts of vehicle decel/accel values observed in different decel/accel ranges at 32.8 ft (10 m) from crosswalk, for vehicle-crosswalk interactions at passive, active and pedestrian-actuated crosswalk warning sites.

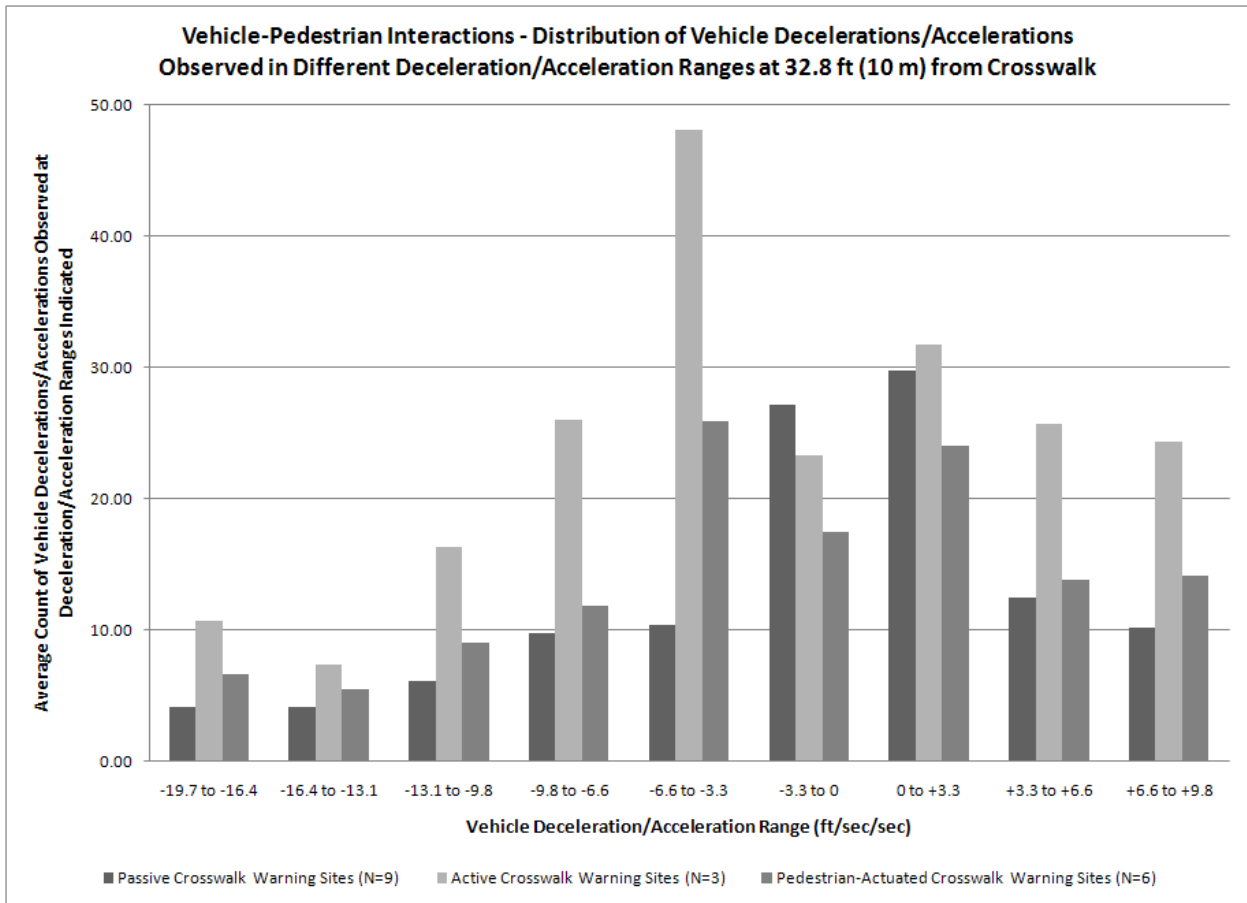

Figure G-18. Distribution of average counts of vehicle decel/accel values observed in different decel/accel ranges at 32.8 ft (10 m) from crosswalk, for vehicle-pedestrian interactions at passive, active and pedestrian-actuated crosswalk warning sites.

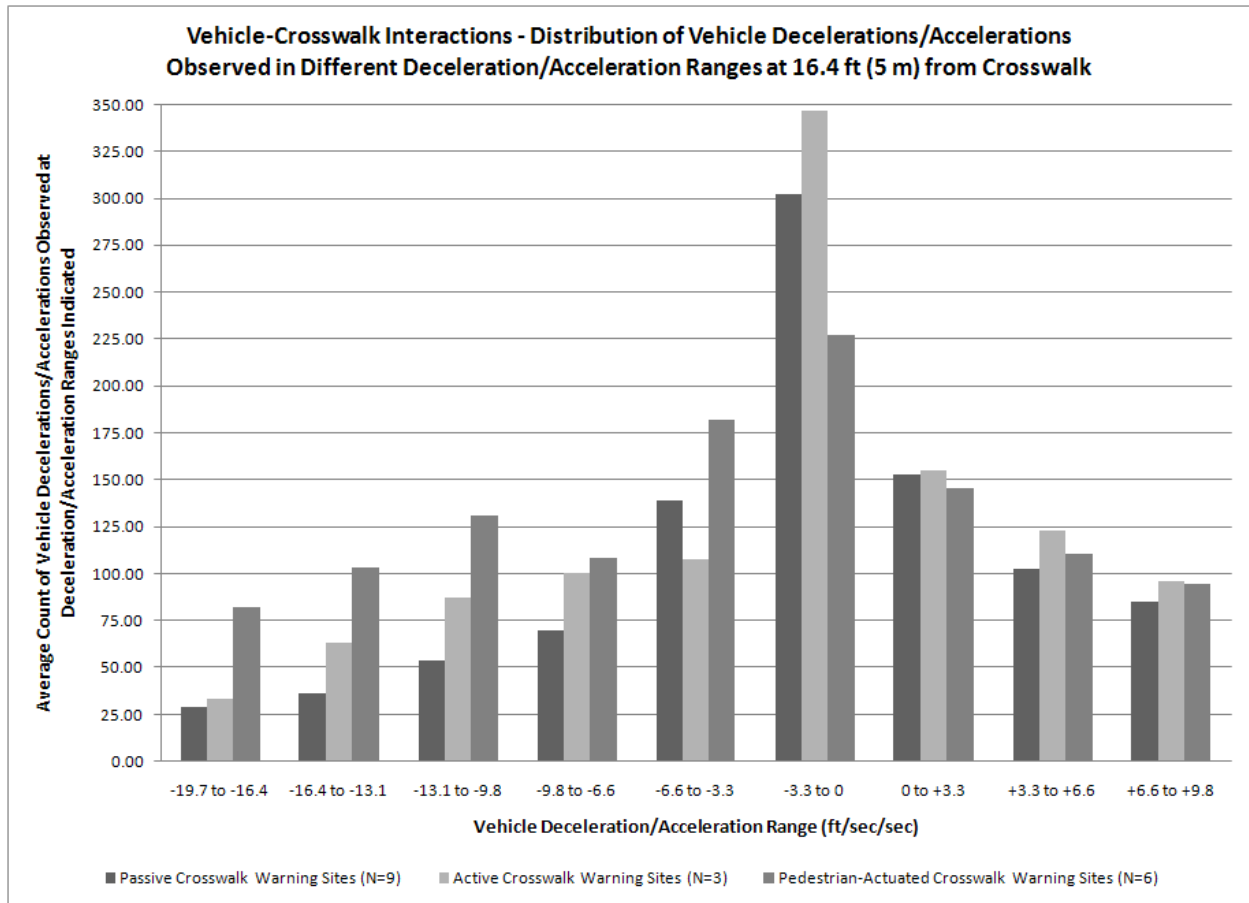

Figure G-19. Distribution of average counts of vehicle decel/accel values observed in different decel/accel ranges at 16.4 ft (5 m) from crosswalk, for vehicle-crosswalk interactions at passive, active and pedestrian-actuated crosswalk warning sites.

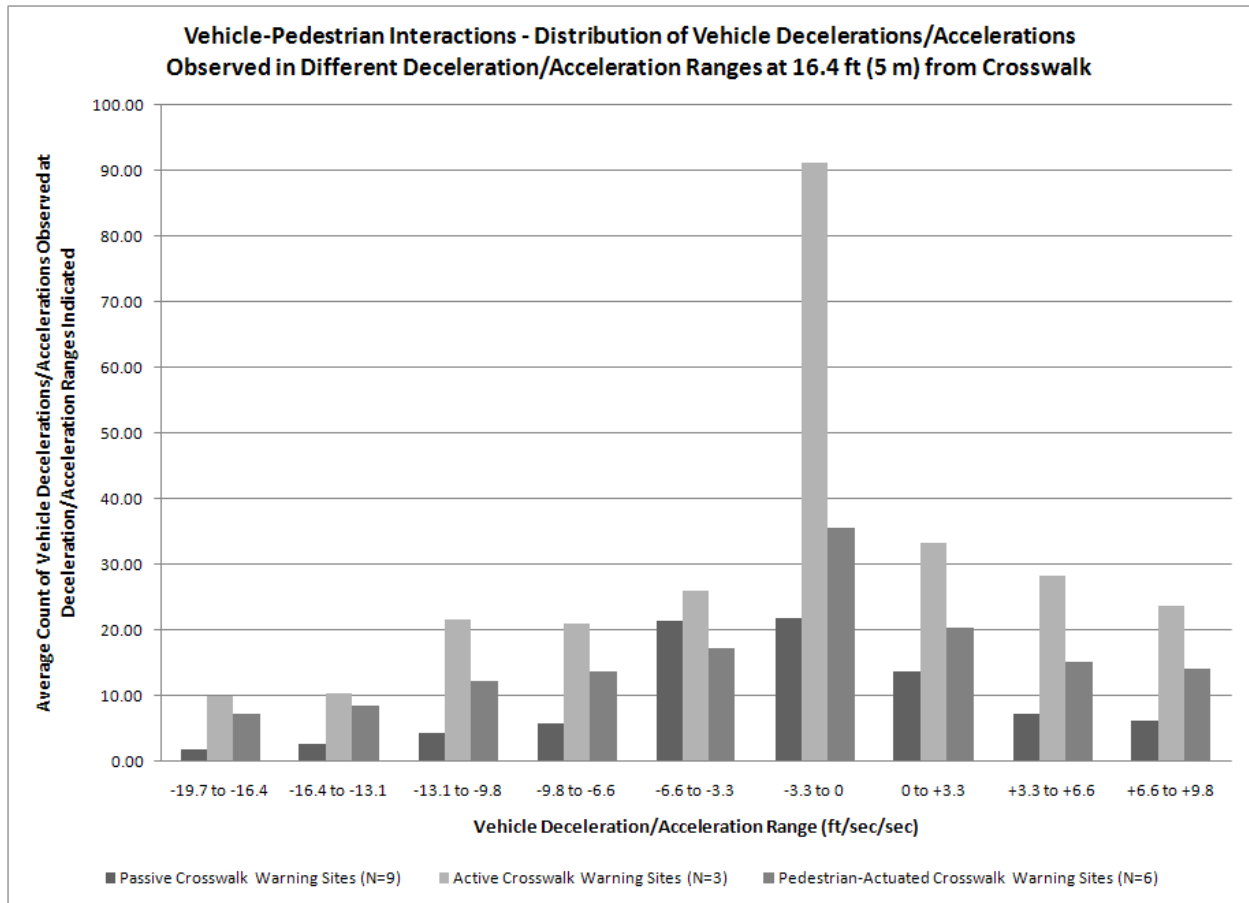

Figure G-20. Distribution of average counts of vehicle decel/accel values observed in different decel/accel ranges at 16.4 ft (5 m) from crosswalk, for vehicle-pedestrian interactions at passive, active and pedestrian-actuated crosswalk warning sites.