

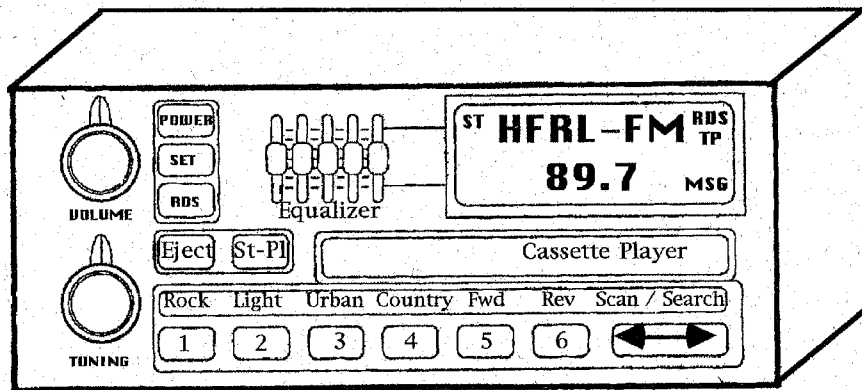

Research Report



Human Factors Evaluation of the Delco RDS Radio Receiver and the RDS Architecture

CTS
TE
228.3
.H86
1994

Technical Report Documentation Page

1. Report No. MN/RC - 95/01	2.	3. Recipient's Accession No.	
4. Title and Subtitle HUMAN FACTORS EVALUATION OF THE DELCO RDS RADIO RECEIVER AND THE RDS ARCHITECTURE		5. Report Date August 1994	
		6.	
7. Author(s) Max E. Burrus, Sara Johnson, Gayna Williams, and Stirling Stackhouse		8. Performing Organization Report No.	
9. Performing Organization Name and Address Human Factors Research Laboratory University of Minnesota 141 Mariucci Arena Operations 1901 Fourth Street SE Minneapolis, MN 55455		10. Project/Task/Work Unit No.	
		11. Contract(C) or Grant(G) No. (C) 70416 TOC #102	
12. Sponsoring Organization Name and Address Minnesota Department of Transportation Office of Research Administration 200 Ford Building - Mail Stop 330 117 University Avenue St. Paul, MN 55155		13. Type of Report and Period Covered Final Report 1993-1994	
		14. Sponsoring Agency Code	
15. Supplementary Notes			
16. Abstract (Limit: 200 words) <p>This report presents the results of a one year comprehensive human factors analysis on the prototype Delco RDS device supplied by the Minnesota Department of Transportation. RDS devices provide a means of transmitting traffic information to motorist using the existing Traffic Management Center's resources. This study examined the devices and the means of transmitting information using ergonomic and human factors principles. This study expanded upon the functions of these devices and their ability to transmit information, as well as their integration within the automobile. The study was completed by examining the data entry tasks required to transmit messages and the TMC's operations as pertaining to messages and delivery to the end-users.</p> <p>Five tasks were completed with the following findings: Ergonomically, the prototype device requires further refinement to provide a user friendly interface. Linkage analysis and flow charting extracted areas where operations of the device was impeded by design. Simulation and on-road study elicited difficulty in operating the device while maintaining driving proficiency. Highly significant deviations were found between normal driving behavior and driving performance when simultaneously operating the device. This suggests an increase in attentional demand which is placed on the driver operating the device when they should be focused on the task of driving. Finally, assessment of data entry personnel and the TMC operations found several areas for improvement in the Crusader™ message assembly program interface and message content.</p> <p>Recommendations are provided following each task.</p>			
17. Document Analysis/Descriptors In-Vehicle Devices RDS (Radio Data Systems) Human Factors/Ergonomics		18. Availability Statement No restrictions. This document is available through the National Technical Information Services, Springfield, Va. 22161	
19. Security Class (this report) Unclassified	20. Security Class (this page) Unclassified	21. No. of Pages 107	22. Price

**Human Factors Evaluation of the
Delco RDS Radio Receiver
and the RDS Architecture**

Final Report

August 1994

Prepared By

Max E. Burrus
Sara Johnson
Gayna Williams
Stirling Stackhouse

Human Factors Research Laboratory
University of Minnesota
141 Mariucci Arena Operations
1901 Fourth Street S.E.
Minneapolis, MN. 55455

Submitted To
Minnesota Department of Transportation
Office of Research Administration
117 University Avenue, 2nd Floor
St. Paul, MN. 55155

This report represents the results of research conducted by the authors and does not necessarily reflect the views or policy of the Minnesota Department of Transportation.

This report does not constitute a standard, specification, or regulation.

The authors and the Minnesota Department of Transportation do not endorse products or manufacturers. Trade or manufacturer's names appear herein solely because they are considered essential to this report.

Table of Contents

	Page #
Executive Summary	
Chapter 1 - Introduction	1
Objectives	1
Scope	1
Chapter 2 - Task One : Evaluation of static measures.....	3
Introduction	3
Methods of Evaluation	4
Results and Recommendations	8
Functional Requirements	8
Linkage Analysis	8
Recommendations	9
Flow Charting	10
Recommendations	11
Design Ergonomics	11
Text Display	11
Recommendations	11
RDS Mode (RDS Button)	12
Recommendations	13
Traffic Program / Traffic Announcements	13
Recommendations	14
Traffic Announcement Interrupt	14
Recommendations	14
Seek By Preset Format	15
Recommendations	15
Design Recommendations Based On Analysis.....	16
Recommendations From Ergonomic Analysis	18
Luminance Study	20
Results and Recommendations	21
Training	22
Results and Recommendations	22

Chapter 3 - Task Two : Simulation Study.....	25
Introduction	25
Methods of Evaluation	25
Experimental Design	29
Experimental Description	31
Participants	32
Findings / Results	33
Interpretation of Results	35
Simulation Test Results	36
Recommendations	40
Post - Simulation Questionnaires	40
Findings	41
Recommendations	42
 Chapter 4 - Task Three : On-Road Validation.....	 43
Introduction	43
Methods of Evaluation	43
Findings	45
Recommendations	46
 Chapter 5 - Task Four : Pilot Study of Crusader and Operators.....	 47
Introduction	47
Methods of Evaluation	47
Crusader Operator Questionnaires	48
Software Ratings	48
Recommendations	49
Information Collection	49
Recommendations	50
Position of Operator	50
Recommendations	51
Conclusions	51
Information Officer Questionnaire	51
Information Officer Time	51
Questions by Crusader Operators	52
Recommendations	52
Conclusions	53

Chapter 6 - Task Five : Shift Work at the TMC Control Room.....	55
Introduction	55
Information Flow	57
Recommendations	57
Human Factors Evaluation of Messages	58
Recommendations	58
Crusader Software System	58
Recommendations	59
Information Systems	59
Recommendations	60
Workstation Design	60
Recommendations	60
References	61
Appendixes	63
Appendix A : Linkage Diagrams	63
Appendix B : Flow Charts	71
Appendix C : Redesigns of the Delco Receiver	79
Appendix D : Static Tests	87
Appendix E : Instructions for Participants	91
Appendix F : Post - Simulation Questionnaire	95
Appendix G : Trilogy Operators and Information Officers Questionnaires.....	101

List of Tables

Table	Title	Page #
1	Illuminance Levels in Work Areas	7
2	Summary Data by Subject	37
3	Observations Made During Periods of No Data Collection	38
4	Comparison of Each Segment Verses Each Other	39
5	Individual Observations	46

List of Figures

Figure	Title	Page #
1	Linkage Diagrams	5
2	Flow Charts	5
3	Label Positioning of the RDS Button	17
4	HFRL Dynamic Driving Simulator	26
5	Simulated Driving World	27
6	XTAR Graphic Creation Scheme	28
7	Left-hand Turn and Passing Maneuvers	32
8	Example of Means and Variations	33
9	Representative Data Graph Example	34
10	Route Driven By On-road Participants	44
11	HFRL On-road Vehicle and RDS Set-up	45

Table Of Abbreviations

C.O.	Crusader Operator (Crusader Software Data Entry Person)
HFRL	Human Factors Research Laboratory (University of Minnesota)
I.O.	Information Officer
MSG	Message Annunciator (Letters That Appear On Text Screen During Message Broadcast)
RBDS	Radio Broadcast Data System
RDS	Radio Data System or Second Function Button on Delco Receiver
RMS	Root Mean Square Error (Measure of Lane Deviation Collected by Simulator.)
ST/PL	Stop / Play Button For Stopping and Starting Cassette Player
TA	Traffic Announcement Interrupt (Toggle Switch)
TMC	Traffic Management Center
TP	Traffic Program Annunciator (Letters TP Appear on Text Screen When Radio Station Regularly Broadcast Traffic Reports)
TRA	Traffic Radio Announcer

EXECUTIVE SUMMARY

Introduction

This report is part of the Minnesota Department of Transportation (Mn/DOT) Trilogy project for evaluation of radio based traveler information systems for the Twin Cities (Minneapolis-St. Paul) Metropolitan area. The present study's focus was on the practicality and safety issues in delivering traffic information for personal route planning. This real-time information was provided for drivers in cars equipped with a radio receiver that incorporates special features. The receiver in this investigation was known as the Delco prototype receiver.

The Radio Broadcast Data System (RBDS) is a technology that allows the transfer of digital information along with a normal F.M. transmission. A digital channel was added to the regular F.M. signal as a digital sideband which carried the current traffic information received by the Delco receiver. The Delco device resembles in appearance a typical car radio system but with an eight character by two lines scrolling text display on its front plate. To provide a useful human factors and ergonomic evaluation of the Delco receiver requires an evaluation of safety, performance, and public perception of the device.

Testing and Results

The Human Factors Research Laboratory at the University of Minnesota conducted an evaluation of this Delco receiver. This evaluation consisted of the following five tasks; (1). A static ergonomic analysis of all features of the device. (2). An evaluation of a few features of the receiver in dynamic driving simulation. The features evaluated were selected because of their direct relevance to deliver of real-time information. (3). An on-road experiment to validate and extend the simulation findings. (4). A subjective evaluation of the receiver by the participants in the studies. (5). An evaluation of the Crusader message assembly software and the Traffic Management Center's control room architecture.

Human factors evaluation of the Delco receiver, the Crusader Software program, and relevant parts of the control room of the Mn/DOT Traffic Management Center were completed on April 1st, 1994. Findings and recommendations from each task were related to the functionality and practical impact of a system that delivers text messages to a driver's radio.

Task One was a static evaluation of the device including task analysis, task design, luminance considerations and ease of use, and training. While we found that the device was difficult to understand and to operate correctly, the functions of the Delco receiver studied in this task proved that information could be transmitted accurately across a large metropolitan

area and its messages could be interpreted as current traffic information. The delivery of information required only a low cost input computer, message assembly software, an encoder, a signal generator or F.M. carrier, and the in-vehicle receiver.

We suggest that further prototypes of this Delco receiver use an ergonomic approach to redesign where the goal is to reduce and simplify the steps required of the operator to enable the device's functions. To this end we make several suggestions and recommendations including:

- Eliminating the dual functions of all controls and sequential steps needed to complete tasks.
- Using proper labeling and re-positioning commonly used controls to the near side of the user.
- Providing filtering or selectivity on the part of the user to increase context specific information transfer.
- Simplify the manual and instructions. Participants had a difficult time understanding the functions of the radio, and a learning test administered to the participants provided poor results even after an extensive time of studying the instructions manual.

This list points to some of the human factors problems inherent with rapidly developing prototype technology and the need for proactive and interactive human factors engineering.

Task Two was a simulation study of the Delco device in the dynamic driving simulator at the Human Factors Research Laboratory (HFRL) at the University of Minnesota. Thirty-eight people (thirty under forty years of age and eight greater than forty) of both genders who were licensed Minnesota drivers, participated in this testing. Participants drove the simulator at the HFRL on a course designed to emulate two-way, single lane, and freeway traffic conditions. To increase complexity, participants were required to make a left-hand turn and to perform a typical passing maneuver.

Experiments showed that operating the Delco receiver degraded driving performance compared to driving without using the receiver. All subjects had statistically significant deviations in the variables measured including lane drift, acceleration / deceleration changes and speed maintenance, braking and in performing other typical driving tasks.

A post-simulation questionnaire was administered to assess ease of use and practicality of the receiver, with generally positive responses to the delivery of traffic information to the drivers. However, participants were not convinced that these systems provided better information than what is available by listening to traffic announcements on their conventional car radios.

Task Three was an on-road validation of the simulator findings. The HFRL car was outfitted with the Delco radio. The equipment for transmitting to the radio was installed into the car enabling messages to be sent directly to the radio. A ten minute test drive was

conducted on streets near the campus for each of four subjects. An observer in the front seat noted head down time, lane deviations, changes in speed, and atypical driving behaviour. As in the simulator, differences were noted between normal driving and driving during operation of the Delco receiver. These tasks both support the conclusion that driving performance under typical (neither best- nor worst-case) conditions could be degraded by the use of this device. Informed route planning and its desired effect of reducing congestion from presentation of traffic information to drivers using the Delco receiver, must be judged in light of the penalties of degraded driving performance. The nature of this trade-off is clear although its resolution is not.

Task Four was a pilot study of the Crusader Software package that is used in the TMC's control room for the assembly of traffic messages.. Crusader manages the storage, formatting, and passage of traffic messages to the encoder and signal generator. This task focused on the Crusader Operator (C.O.) who enters data at the control room into Crusader and on the Information Officer (I.O.) who tracks all incidents and facilitates information transfer. The I.O.s are a main resource for answering questions on accident location and severity. We found problems with the design of the software including the failure to prioritize data so that the most frequently entered data was on the top of the list. We also noted physical layout difficulties at the control room and workload problems for both C.O.s and I.O.s, which was further examined in Task Five.

For Task Five a member of the HFRL staff becoming trained as a ramp meter operator at the control room. This person also completed reports on ergonomic and human factors issues in the control room. Several points are raised to suggest redesign of the current layout. The main points raised in this task are:

- Evaluation should be completed on the types of messages sent to increase consistency of the messages.
- The architecture of the control room should use workload analysis and adopt a user centered approach to increase efficiency.
- Evaluation methods for message content and prototype review should be revised and strengthened to increase the ability to collect valid data during an operational test.
- Finally, the workstations of the operators should be examined to improve sight angles of all personnel in the control room.

Conclusion

The goal of the Delco receiver was to demonstrate the technology for the delivery of traffic information to drivers. The Delco achieved this goal but not without introducing the potential for degrading driving performance and thus, driving safety. In addition, there is a need for human factors improvements to the information delivery system at the TMC's control room.

CHAPTER 1

INTRODUCTION

This report is divided into five sections to coincide with the five tasks undertaken by the HFRL. All tasks have an introduction or summary, the methods used (where applicable), the findings and results, and finally the recommendations.

OBJECTIVE

The objective of this human factors evaluation is to examine the Delco receiver in a static state and in dynamic simulation to determine functionality as a medium to deliver traffic information to an automobile driver. This required testing its functions as a way of receiving the real time information from the TMC control room. We examined the receiver's luminance qualities, where if the text screen is not bright enough during night time driving it will not be of use to the driver. Likewise, if the button labels on the receiver are washed out or glared over by bright sunshine drivers can not operate it. We looked at training and learning required to become proficient in operation of this prototype device as a measure of user satisfaction. We evaluated the attention required to operate the device in simulation as a function of changes in normal driving behaviour. Finally, we studied the architecture of the information transfer system to develop recommendations for improving delivery of useful information to the driver.

SCOPE

The scope of this study is to evaluate the Delco device in three areas; safety, performance, and public acceptance. In this limited study, we can provide only results on the tasks conducted. We attempt to extrapolate the results to define the safety, performance and public acceptance of the Delco receiver, but the breadth of a comprehensive study of this receiver would require more extensive examination. We have set out to determine statically and dynamically measures of the scope as defined below.

The first area of interest is safety. Safety is a prime concern when adding features of any kind to a vehicle which travels on the roads. The aim of a human factors evaluation is to assess whether using these new features distracts the user from the primary task of safely driving the car. Consideration must be given to the ease and efficiency of operation of the device, as well as the distraction caused by the device. Our evaluation of the Delco device required looking at the way the receiver is operated, and the way in which the driver acquired and used the information supplied by the device and the consequences of acquiring that information.

Performance is the issue when we consider the population of prospective users and their ability to successfully operate the Delco receiver. The user performance results are closely associated with safety. In this report we considered the usual human factors issues subsumed under the generic phrase, 'user friendliness', but of more fundamental significance, we assessed the effect of the Delco receiver usage on driving performance. Performance in this context has required us to use several different measures including task analysis, simulation study, and architecture / hardware review.

Finally, one of the major concerns regarding the implementation of new technologies is public acceptance. Public acceptance, in turn is predicated largely on our ability to introduce technologies to make their advantages to the driving public completely obvious. That is, the new technologies must be part of a system which is easy to understand, easy to use, and of obvious benefit to the user. An assessment of drivers acceptance required considering the match between the 'wants' of the user with the functions provided by the Delco prototype.

CHAPTER 2
TASK ONE:
EVALUATION OF STATIC MEASURES.

INTRODUCTION

Task One of our evaluation consisted of a static evaluation of the Delco receiver. First, we conducted a study of the functions which could be performed by the device. This included descriptions of the ways in which users could avail themselves of these functions. We have analyzed these functions using human factors methods such as link analysis, flow charting, and redesign. This allowed us to apply ergonomic principles to define a “best case” design and highlight possible revision that could be useful as either a guideline for design or as a foundation for evaluation of subsequent devices.

The second purpose of Task One was to evaluate the receiver through static tests. For this subtask, we installed the Delco receiver in a vehicle and conducted static evaluations without using simulated driving. These static test consisted of; (i). luminance measurements to assess the effects of varying environmental conditions, and (ii). training / learning issues to see in detail how well users could access the available functions and learn to use the device from the manual.

To facilitate analysis the main task was divided into sub tasks. The first subtask was an ergonomic and human factors breakdown and evaluation of the physical properties of the receiver; that is, how well did it perform, how was its design conducive to safe, easy operation, and what revisions could be implemented in redesign or future generations of prototypes. Although this level of detail was often not necessary in the context of a pilot project it helped to define the tasks that followed, specifically the simulation tasks.

The second subtask was to measure luminance qualities of the text screen, as this was the main information transfer interface. If the text screen was difficult to read under varying lighting conditions it added to the complexity of the device. This led to either poor performance when using the device or to driver dissatisfaction and subsequent reduction in using or trusting the device.

The final subtask dealt with training operators to use the device and establishing whether the device’s functions could be operated properly by novice users. Novice users will, after a time, demonstrate a learning curve and move on to become more experienced or expert users (Schneiderman, 1986). We wanted to establish whether novices can use the functions and recall sequences after a short interval of time. If a device is difficult to learn it will not be trusted and will not gain the confidence of the user. (Konz, 1992).

The data we collected and analyzed in Task One enabled the design of efficient simulated driving experiments in Task Two. This data and its analysis also allowed us to suggest certain design changes which might improve the operation of the device while driving.

METHODS OF EVALUATION

Subtask One : Functional analysis and redesign.

The main goal was to use ergonomic and human factors principles to evaluate the functions, the steps required to illicit these functions, and the physical layout of the Delco receiver.

We first became expert users of the system. We then separated the functions available on the receiver and concentrated on those having direct relevance to the pilot test. We then assessed the design of the receiver to evaluate its usefulness and practical design. The method we used to accomplish this was task analysis. In task analysis we established the actions or behaviors individuals must perform to fulfill the requirements of device operation. To study these actions we selected three methods of task analysis based upon Wilson and Corlett's ergonomic methodology. We used linkage analysis, flow charting, and design ergonomics (Wilson & Corlett, 1991).

Linkage analysis is a process of discovering the steps or sequences of movement involved in a single operative procedure. Lines or links were drawn between each step in a sequence. A starting point was established and then all buttons pressed and their related response actions were connected by links. This allowed us to visualize if related controls and displays were close to each other, if they required redundant steps, or if the progressions of steps was in an unnatural order. For example, we studied the effect of hand and eye coordination and control button presses to initiate several functions. An example was seeing the message indicator light, initiating RDS functions, and scrolling through an eight line message. We used a two dimensional drawing of the face plate of the Delco receiver and established the "links" in moving one's eyes from a static position down to the radio to see a message indicator, to pushing the RDS button, and pushing the volume knob (it scrolls messages in RDS mode) four times. At the same time the user must read and comprehend each message which required looking at the message screen between each button press of the volume knob. In the end we trace this progression of steps on the two dimensional drawing resulting in a diagram resembling Figure 1. This diagram does not show the complex movements of a driver as they use the device and glance quickly at the radio and back to the road. It is only a drawing of the progression and linkages. These links may only require split second diversion or low levels of attention but a drawing of this helps us to understand the progression of movements and attention to tasks.

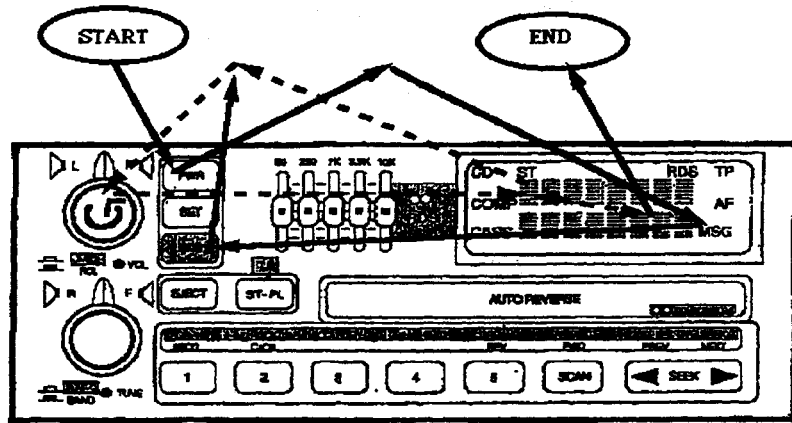

TASK: NOTICE MSG. ANNUCIATOR, VIEW MESSAGE.

Figure 1. Linkage diagram showing arrows representing eye, head, and hand movement to initiate and complete text reading.

We use linkage analysis to define the complexity of each task and to design simulation studies to bring out the difficulties in operating a device that required this many steps. Finally, it allowed us to develop an overall relationship between the physical elements of the receiver and the task to be performed (Chapanis, 1959). (See Appendix A. Linkage diagrams).

Flow charting allowed us to analyze the decision making process necessary in operating the device. (Figure 2). If a user was given several choices or sequential choices to reach a single goal, it might be diverting the drivers attention away from the primary task of driving (Hancock, et al, 1990). In flow charting we selected the starting point of one of the functions to be performed on the receiver.

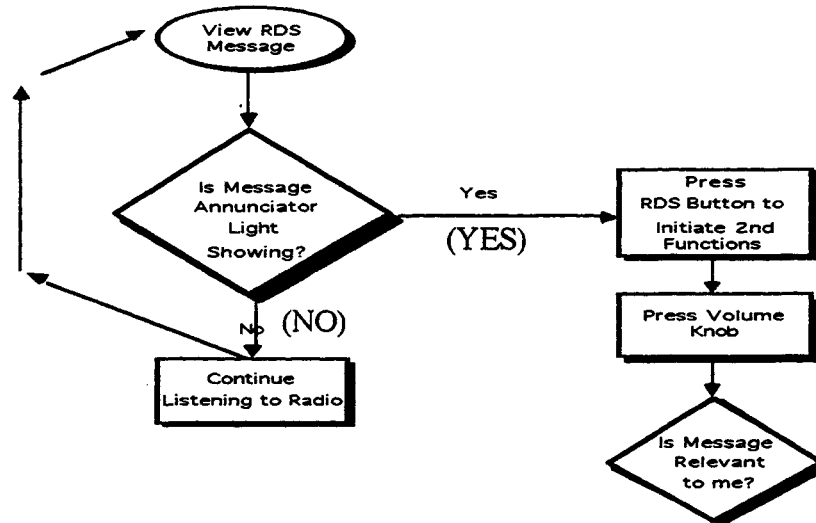

Figure 2. Flow diagram showing main task as an ellipse, decisions as a triangle, and physical steps as squares. Arrows connect the boxes in the direction of the steps taken to complete the task.

The chart was then formed by using a method designed by logistic and computer programming specialists, where decisions were answered "Yes or No" with the resultant actions connected by arrows to other decisions until a solution or completion of the task was reached. This allowed the development of a scheme of decision making which was used in simulation study design to determine the levels of complexity of the tasks. (See Appendix B. Flow diagrams., for complete examples).

Finally we use design ergonomics to determine whether: the buttons were conveniently spaced, the steps followed a logical order, and the most frequently used buttons were in the easiest place to see and reach. These principles have been well established through military research (U.S. Dept. of Defense, 1981 & 1989). We also used the guidelines collected by Woodson, Tillman, and Tillman in the Human Factors Design Handbook (Woodson et al, 1992) and those used in design of the Automated Highway System by the Honeywell Technology Center. (Burrus, Dewing, & Levitan, 1994). We discussed the design changes necessary for ease of operation and where appropriate we cited the reference that established the design guideline used. We limited the discussion to design changes which were relevant to text screen operation or RDS function. Three redesign possibilities are listed in the appendixes to this document. (See Appendix C. Redesigns).

Luminance is a measure of the light emitted or reflected from a surface. Illuminance is the measure of the amount of light on a surface from a direct or indirect source of light (sunshine, car dome light, or streetlight).

Note: Luminance levels are measured in " cd/m^2 " or candela/meter squared. While, Illuminance is measured in foot candles and can be converted into the international measure "lux" where $1 \text{ lux} = 0.093 \text{ foot candles}$ (or 1 lumen/m^2 .)

To measure luminance and illuminance we used a standard photometric light meter which was standardized to cd/m^2 and foot candles. The luminance contrast was very low for the device, therefore, luminance could not be measured directly from the labels nor could we measure reflectant light from the text screen. Thus we could not measure the luminance contrast of the legend on the backgrounds of the buttons.

Instead we took an approach where we measured the darkest and brightest illuminance where the legends on the buttons could be read clearly. We in essence measured the two extremes of the ambient illuminance threshold for reading the legends on the button. This meant that we determined the illuminance level at which the labels could no longer be read.

Performing this task meant that the data was only relevant to the low illuminance levels associated with tunnels, dusk, dawn, and night or to high illuminance associated with bright light situations. Both darkness and bright light, especially light which was directed at the display, posed differing problems. At low ambient illuminance, reading the buttons was the

problem, and reading the back-lighted LCD display was not. At high ambient illumination levels the buttons were legible but the display was washed out. We determined the threshold illuminance level for reading the display when the light was shining directly on the display. This condition could pertain when the sun was at a low angle in the sky and shining through side or rear windows. We also determined the threshold level for reading the display when the ambient illumination was high but diffuse and not directly shining on the display. We decided to use six mixed age and gender participants to describe under what lighting conditions they would decide that they could not read the display. We then measured the calibrated amount of light we were projecting on the radio to estimate the amount of direct or indirect light necessary to wash out or glare out the display. This value is compared to the illuminance standards in Table 1.

The readings we took should fall outside the Minimum and Maximum levels if the system is well designed for illuminance considerations. In other words, if our measured values (which told us the minimums and maximums of readability) fell within this standard range, we infer that ambient lighting conditions prevalent within our environment could seriously affect the ability to see or read the buttons, labels, and text.

TABLE 1. Illuminance Levels in Work Areas

Work Area or Type of Task	Task Illuminance, footcandles		
	Minimum	Recommended	Maximum
Panels, primary operating area	20	30	50
Seated operator stations	50	75	100
Reading : printed or typed	20	30	50

*Illuminance required in working area and to perform task taken from
Illuminating Engineering Society, (1981) pp. 142-143.*

Finally, we estimated the ease of learning the functions of the receiver by testing subjects after they had studied the owners manual. We employed a memory test, a quiz, and a task performance test. Subjects who had never seen the Delco receiver or its manual were asked to read the manual and then take a brief test. The test consisted of three parts. The first was identifying features on the radio interface. Subjects were provided with a diagram of the interface with no labels on it and asked to label a selection of the buttons and features. The second part required subjects to answer ten short questions on functions and features of the radio, for example, "How do you know a traffic message is being broadcast?" or "You would use the Tuning Knob to scroll through different messages (true/false)". The final section had

the subjects perform a complex task that was described in the manual. (see Appendix D for a copy of the learning test).

Subjects were given thirty minutes to read the manual. The first group was given an unlimited amount of time to complete the test with access to the manual. They were asked to complete the test and were allowed to use the manual as a guide. The test was then repeated with different subjects, but this time access to the manual was not allowed. Subjects were required to struggle through any problems and could not reference the manual.

RESULTS AND RECOMMENDATIONS

Results of each type of static test were listed and followed by recommendations on the issues raised in analysis of each. We discussed each sub task separately and then integrated the relevant points in design recommendations.

To obtain these results we:

- Evaluated the static measurements we made as part of Task One;
- Reviewed the findings from link analysis and flow diagrams;
- Specified the principles of design that needed to be reviewed;
- Suggested different configurations;
- Integrated the task findings into Task Two for the driving simulation experiments.

FUNCTIONAL REQUIREMENTS

A summary of the functional requirements for the Delco Prototype system is presented here. We consider both the capabilities of the receiver and the human factors critique of the functionality.

Linkage Analysis

The use of linkage analysis proved that the Delco receiver required complex actions to initiate tasks. The radio controls are similar to a calculator with a second function button. In other words, all controls on the receiver are dual function controls. In normal operating mode a knob may control volume settings, while in the RDS or second function mode it becomes a press / release button controlling message scrolling. The linkage diagrams show that all relevant functions dealing with text transfer require at least two steps; (i) pushing the RDS button, and (ii) initiating the task. This is an unnecessary sequence of steps. The only time that the RDS function can be operated is if the radio station is broadcasting with RBDS. A simple rule says that if something external can activate an internal function, it should, instead of the user initiating the action since it eliminates the need for diverting one's attention.

It is reasonable to assume that the receiver could detect when a station is broadcasting RBDS and therefore, could automatically activate the RDS functions. In this way the RDS (second function) button could be eliminated. At the same time the number of steps in a sequence would be reduced, decreasing the amount of time the drivers devoted to the receiver to perform RDS tasks.

The Military Handbook 759A which lists human factors guidelines in design states:

If two or more controls are operated in the exact same sequence each time they are used and they only perform one task in this sequence, then combine the controls into one control that performs all of the steps. Make the sequence of steps invisible to the operator. Controls should be combined to eliminate the need for multiple control actions to perform a single function. (U.S. DoD., 1981, p. 3).

It is very clear from examining the linkage diagrams that the physical controls that the operators press to initiate a task are not located next to the task or to other related buttons. Several of the sequences we studied from a functional operation standpoint required pressing a button at the far left bottom, looking at a screen at the far right top, pressing a button on the far left top, and then looking back to the far right. An example on the current radio is the position of the set button. You must press the button at the top far left of the receiver and then move to the bottom right to seek for a station to set. The buttons that make up a sequence should be in close proximity to each other. In several sources this is listed as one of the most important principles of design:

All controls that function in sequential operation or operate together to perform a task, should be grouped together. The controls that are operated sequentially; "first this, then this, then this", should be placed in order next to each other either in a top to bottom or left to right arrangement. (U.S. DoD., 1981, McCormick & Sanders, 1982).

The other major consideration from linkage analysis is the number of control presses needed to read an entire message. Because of the layout of the text screen (eight characters by two lines by four groups), the driver is forced to scroll through four screens. In one sense the receiver is forcing drivers to look down at the screen, up at the control, and back to the screen, four times. This means that at four times every message the driver must look at the text screen to read and understand an eight character by two line chunk of a message.

Recommendations based on linkage analysis

- Eliminate the RDS (second function) button and internalize within the radio the ability to detect RBDS broadcast and initiate RDS functions.

- Reduce the number of steps required to initiate and complete functional tasks.
- Combine steps into one control action that requires one button press or glance at the radio
- Eliminate the scrolling function of the screens by using one of these methods:
 - (i) Use a constant scroll, similar to an advertising board where a message rolls across the screen from left to right.
 - (ii) The driver could initiate the reading of a message and the screen could show all lines of the text in order. First it would display line one and two, wait five seconds, show line three and four, wait five seconds, etc. It could then recycle through the message until stopped by the driver.
 - (iii) Increase the size of the screen to accommodate larger messages (sixteen or twenty-four characters per line of text).

Flow Charting

Flow charting made us aware of the difficulty in performing even simple RDS functions. We reasoned that if these task require such complex actions in a static environment, they would be compounded in complexity while concurrently doing dynamic driving tasks. These diagrams showed that not only was the operator of the receiver making several choices for one task, but to progress from one choice to another required several actions or button presses. In the same way, operators did not have a clear default state. For example, if a choice was negative, the progression of steps did not always lead back to a single previous step. Operators might answer “no” to a choice or condition and be led along another path, with other choices or button presses, to return to the original choice. A well designed system should have a defined set of defaults where if an action was not initiated it should return to the previous question. The Delco receiver’s default was that if a decision was not made in five seconds then the RDS functions were turned off and the controls returned to normal operating mode. This had the potential for frustration if the user was moving through a complex task, they paused for a brief five seconds, and lost all of the steps that they had previously entered.

In designing the possible tasks to be completed in simulation it became clear to us through these flow charts, that a simple task would be sufficient to elicit changes in driving performance and attention. We preferred to have the participants in simulation study use the Delco receiver for its primary purpose of delivering traffic information. It was shown by these flow charts and the linkage diagrams that the “simple” task of reading traffic messages was actually quite complex requiring several button presses and decisions by the drivers.

Recommendations from flow charts

- Reduce the number of steps and button presses necessary to complete tasks.
- Internalize or group button presses into one action / one response tasks.
- Establish defaults that return users to the previous point in sequence, not back to the beginning. Never leave the user in a confused state following a user's error.
- Decrease the amount of decisions and control actions necessary to complete tasks.
- There is no need for a five second window before initiating the next action. As discussed in previous recommendations allow the radio to continuously be in RDS mode if the station is broadcasting RBDS.

DESIGN ERGONOMICS

Here we used two types of design analysis. First, the functions of interest to the pilot test were defined and problems were examined as to their performance. Secondly, the physical layout was examined and design possibilities were suggested to reduce ergonomic problem areas.

Text Display

Text is shown on the face plate of the Delco receiver. This text could be music titles and artists, news or sports flashes, advertisements, weather, traffic, and so on. Anything that can be condensed into sixty-four characters could be broadcast and appear on the display. The main function for the pilot test was the transmission of real time traffic information. When a traffic message had been transmitted via an FM carrier, a message annunciator (MSG) light appeared on the display, signaling the presence of a message. The actual letters "MSG" appeared in the lower left hand corner of the text screen. After users noticed that the MSG was lit, they could view the message by pressing the RDS button and then pressing the Volume Knob for each screen of text. Each screen consists of up to sixteen characters on two lines of eight, therefore, allowing up to four screens of information to be displayed. If the Volume knob was not pressed within five seconds of pressing the RDS button, the display would return to its normal operating state. The last message broadcast was stored until the radio was switched off or a new message was sent.

Recommendations

- Provide a way for the MSG annunciator to differentiate between old, stored, or new messages. Perhaps after a message is read the MSG annunciator can turn off. The message will still be stored until a new message is broadcast in case the user wishes to re-read the message. When a new message is broadcast the MSG will reappear.

- Sending traffic information to the public to involve them in traffic management is a worthwhile goal. However, radio stations will want to transmit their prioritized information via the message screen (advertisements, contest information). This may clutter the digital signal airwaves. It may be necessary to devise a standard for the type of information sent, where traffic information should be the highest priority.
- Five seconds is not enough time to read the text screen or press all of the control buttons. Extend or eliminate this time limit.
- The text screen is very small and eight characters does not allow complete words to be transmitted. This is especially important when considering how to get the necessary information to the driver in sixty-four characters including spaces. Careful consideration must be continued in developing messages to relay the maximum amount of information using the least amount of letters.
- Use a longer screen that can handle more characters.
- Different automobiles have different areas where radios are positioned. In a Delta 88 the radio is quite high, in a Camero it is very low. This will cause variation in the ability of users to read the text because of distance from them and angular direction of the screen (parallax problems). The text screen must take into account all of the possible positions of the radio and adjust the size of the text accordingly.
- Consider alternatives to having the screen on the face plate of the radio. Use a detachable screen that can be positioned closer to the driver. Use head-up displays as a way to keep the driver looking forward.
- It is extremely difficult to read the annunciators (MSG, RDS, TP, CASS, etc.), that appear in the corners of the display. Use other means of signaling the driver. A diode light that flashes when messages are being broadcast is one example. Audible tones or using the traffic announcement interrupt are others.

RDS Mode (RDS button)

If the "RDS" annunciator was displayed on the text screen, then that station was broadcasting digital information and the RDS functions could be used. To have access to the RDS functions the radio must be in RDS mode. This mode was entered by pressing the RDS button. Simultaneously "RDS Mode" will appear in the upper part of the text display. If no other control was operated within five seconds of pressing the RDS button, the system returned to normal radio mode. That is, the buttons operated in normal, non-RDS, fashion. We emphasize that the RDS button only facilitated the secondary functions of the controls. It did not allow or change the radio to RBDS reception.

When the RDS button is pressed and the selected station was not broadcasting RDS, the display still showed "RDS Mode" with no text. However, several of the alternative functions of the radio could be accessed, the traffic announcement interrupt could be canceled or activated, or the radio could search for a specific radio format.

Recommendations

- The purpose of the RDS button was to change the operating mode of the system. It may be possible to organize the interface to reduce the use of the RDS button thus reducing the time drivers are distracted from observing traffic and the road. If the default case is that when the radio is tuned to an RBDS broadcast frequency, it automatically enters RDS mode, then the user automatically has the RDS mode functions available. When the radio is subsequently tuned to a non-RBDS station, the RDS mode functions are canceled. If the RDS button must remain, an evaluation of the timing of the mode needs assessment. It may be necessary to increase the length of the default ON time to more than five seconds. If RDS mode comes on automatically following tuning to an active RBDS station, then the RDS controls could remain available while the receiver is tuned to that station. RDS mode is canceled when the radio is tuned to a new frequency.

Traffic Program/Traffic Announcement

The Delco receiver provided a method by which the user could be aware if a radio station was providing traffic information. This could happen in two ways: (i). users may wish to know if the station they were receiving broadcasts traffic information periodically, (ii). users might wish to tune to a station that was in the process of broadcasting traffic information.

The Traffic Program annunciator (TP) indicated that a station regularly broadcast traffic information and 'TP' appeared in the display when relevant. The Traffic Announcement code (TrafficA) is a flag which indicated that a traffic announcement was in progress. This appeared on the lower line of the text display when the traffic announcement was made. If the receiver was set with the traffic announcement interrupt function on, it could interrupt cassette tapes when a message was being broadcast with the TrafficA flag. If a playback device was in use, the receiver automatically stopped the playback device and switched to the radio so that the traffic announcement could be heard. Only the previously tuned station would interrupt the playback device for traffic announcements. A listener could choose, at the push of a button, not to have the playback device interrupted. It was possible for the receiver to search for stations with periodic traffic announcements (ones that would display TP) , or to search for traffic announcements or text messages in progress. This was achieved through using the

format function and selecting TrafficP or TrafficA as the format. This meant that while searching in the TrafficP format the radio stopped at any radio station regardless of content or format type, that declared it had periodic traffic announcements at some time during the day. Likewise, if several station were broadcasting live traffic announcements (TrafficA) or text messages the radio could search for them if the stations indicated they had announcements in progress.

Recommendations

- Eliminate the TP annunciator. Even if a station displays TP it may not broadcast any traffic information except for morning rush hour. This will not help the commuter or user looking for occasional traffic information in the afternoon. They will tune into a TP station and never hear any traffic information. Instead, users will probably use the TrafficA function to seek traffic announcements in progress.
- A single traffic announcement button could initiate scans for live traffic information or text messages and would provide the user with this access only when desired.
- If the user scans for traffic announcements and the radio finds a station, the radio does not return to the user's original station after the message ends. This means the driver has to look down at the radio and establish where they are on the dial or tune back to their original station. A return button or internal function needs to be provided to return the user to their previously tuned station when the TrafficA broadcast is completed.

Traffic Announcement Interrupt

A facility was provided that allowed the user to have a playback device interrupted when the previously tuned station broadcast traffic information (using the TrafficA format). When a traffic announcement or text message was in progress the playback device was interrupted and the volume was preset at a nominal level to provide the traffic details. The user could return to the playback device by pressing the ST-PL (stop / play) button at any time. Otherwise, the device would return to the playback mode after the announcement was concluded. The user had the ability to choose not to be interrupted by traffic announcements. This was possible by pressing the RDS button and then ST-PL button. The display then showed the current status of the function, "TA-On" or "TA-Off". This feature could be toggled when in playback mode.

Recommendations

- The TA only operates when a playback device is in operation. Therefore, a user tuned to a radio station cannot use the traffic announcement interrupt. It only works while

using a playback device. This needs to be a universal mode change when using any function or radio control. The traffic announcement interrupt should work while listening to any other radio station or the playback device.

- Having a tape interrupted is an uneasy situation. If the nominal radio volume is radically different from the cassette playing it can startle the driver. To increase the ability of the driver to notice when traffic announcements are broadcast and reduce surprises, visual or auditory cues may be required before the traffic announcements are made. This may reduce startle when the volume is altered and the broadcast is transmitted. Automatic gain control for the volume would achieve this same goal.
- Toggling the playback interrupt consists of several steps. This should be a programmable preference. If drivers want interruptions they can set playback interrupt as the default. If they never want their tapes interrupted, they should be able to set the TA toggle permanently off. Users will not prefer a system where every time they turn on their radio they are forced to change a default that requires an override operation to cancel. This is a general idea that should extend to all default settings. The goal of human factors engineering is to reduce the time drivers spend changing settings or eliminating defaults and not paying attention to their driving. To make this receiver into an expert system that users can preset before driving will reduce the potential for decreases in driving performance.

Seek by Preset Format

Users could search the radio stations present in a metro area by selecting a type of music. We mention this here because this function points out the excessive amount of choices available to the driver while operating a vehicle. The user can change the current format to one of thirty-two different formats, five of which are preset. To change the formats requires the user to press the RDS button followed by pressing the preset button, followed by the Seek Up/Down button to select a station.

To change the format to one that is not preset, requires the use of the tune knob. The user pushes the RDS button, then searches through the thirty-two formats by using the tune knob. The formats are displayed in the lower part of the display. When the user has found the relevant format, the user then presses the seek up/down button.

Recommendations

- Searching through a list is a very demanding task especially when driving. Assessment of the number of choices offered to the users could help to narrow the format categories available, and therefore, reduce the search demand.

- Users already have a choice of up to six favorite stations by using the normal set buttons for the radio. It would be preferable for the users to be able to program six favorite format buttons in the same way. This would provide each user with a personal selection of only their favorite formats reducing the number of times needed to search through the list of thirty-two formats. This is an example of the breadth versus depth issue in menu hierarchies. For frequent and familiar users, breadth options which allow fewer mode selections are preferred. The frequent users will only use a few choices in a menu and not need a deep list of selections.

DESIGN RECOMMENDATIONS BASED ON ANALYSIS

Ergonomic principles from texts by Woodson, Tillman & Tillman, (1992), Woodson & Conover (1964), McCormick & Sanders (1982), the Department of Defense (1989 & 1981) and work completed by the Honeywell Technology Center (1994) which established guidelines for automated vehicle control, were used to evaluate the design of the Delco receiver and to suggest redesign layout possibilities (See Appendix C. Redesigns)

The first area examined was the controls and their associated labels. The Delco radio was not overburdened with controls because of the use of dual actions on several buttons. As we previously discussed this could be a disadvantage, but here it helps reduce clutter. Previously we discussed positioning of controls to keep related controls next to each other and to keep sequences of buttons near to one another. We offered three redesigns that moved related controls next to each other. We also suggested possibilities where redundant functions or unnecessary functions (RDS button) could be eliminated and replaced by other controls.

Controls should be designed so that operators could operate them without having to glance at them. An example was having a round knob next to a square one. The operator knew the round knob was tuning and the square knob was volume by tactile sense. They felt for whichever control was round when they wanted to tune the radio.

The labeling of the controls was a major problem. The use of grays to label secondary functions actually facilitates washout and decreases dark lighting effectiveness. All secondary functions labels should have a high luminance and color contrast such as red on light gray to counter the dark color of primary functions. The U.S. Department of Defense specifies:

Controls with similar functions or purposes are to use similar coding. If several controls operate the same type of functions they should all be the same shape, and/or color. Use shape and color to provide quick visual reference to where all the controls that perform similar functions are. This facilitates scanning large control areas. If color coding is to be used select high contrast colors, Blue/red, Black/white, Gray/white, Dark/light. (U.S. DoD., 1992, p. 29)

There were also positional problems in the labeling structure. Workspace design and normal conventions of labeling are that labels appear above or below their respective controls. The Delco receiver places a label on each control. At night when the buttons are not distinguishable, operators who were accustomed to correct labeling pressed above or below the buttons. This was the prevalent response in our static learning test as well as in simulation. For example, drivers pushed the eject button of the tape accidentally when trying to activate the RDS button. The driver's perspective was that the label must be above the RDS button (not on the button) and they press the area between the two buttons (Figure #3).

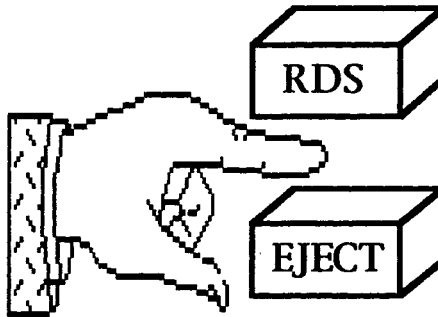

Figure 3. *An operator trying to press the RDS button in the dark can only see the labels and assumes that the button is below the label. The operator then presses between the two buttons hitting both the RDS button and the Eject button.*

After drivers became familiar with the Delco receiver this became less of an issue. However, drivers might have initial frustration, increasing attentional demand and decreasing satisfaction.

Woodson, Tillman, and Tillman described the following guidelines for labeling on controls:

Control labeling on knobs should follow these guidelines: (a) Locate labels where they can be read from left to right. (b) Avoid locating labels where they will be blocked by equipment, the control, or the operator. (c) Do not put labels on controls. (d) Put labels below controls when above eye level. (e) Put labels above controls when below eye level. (f) However, be consistent in label positioning throughout a control panel so operators know where to look. (Woodson, Tillman, and Tillman, 1992, p. 440.)

The final area of interest was the lack of filtering. The Delco system received and displayed all messages regardless of content. This meant that a driver only interested in driving in North Minneapolis had to read all of the messages including the entire Metro Area. This was very inefficient for drivers who want information that was specific to their routes.

Future generations of this device should include some form of filtering would enable users to select messages that are context specific.

RECOMMENDATIONS FROM ERGONOMIC ANALYSIS

The following are general recommendations that could be implemented for the design of future devices.

- A possible redesign may require a new configuration of buttons. We suggest that the traffic announcement feature be provided with a unique button that allows instant scanning and return to original broadcasts.
- It may be worth considering removing the ST-PL (stop/play) button of the cassette tape, because with many playback devices if the disc/tape is inserted it is played and to stop the tape it is ejected. This implies that the ST-PL button is a redundant feature.
- A design possibility may include the removal of the RDS button that only serves the purpose of accessing secondary functions of buttons. A new configuration of buttons could reduce the need for so many secondary functions.
- At present the tuning knob and volume knob are multifunctional and cumbersome. They are very close in distance (1 inch), and are hard to manipulate. This is a major consideration if the drivers are wearing gloves in the winter time. They will not be able to reach between these knobs. Separating these knobs or reducing the number of functions each knob can control will improve ease of use.
- Switching the equalizer and the message display screen would allow the screen to be closer to the driver and centers it between the driver and the passenger.
- We suggest that all five program buttons be available to the user for setting formats. The procedure by which they are set is similar to that discussed previously, again emphasizing this is to be done when the car is stationary.
- To select a format the number of steps can be reduced to two. Pressing the tuning button puts the system into format mode then the selection of the format can be made by pressing a preset format button.
- The interface design should be obvious at a glance and should be easily operated by touch. To achieve this we suggest that tactile cues be given to users. A raised bump on the middle program button can provide orientation. Users can then tell by touch which button their finger has located without needing to be distracted from the driving field of vision to look at the radio. In other words, to increase the driver's ability to operate functions while driving and to minimize the time looking away from the driving field, a raised bump might be added to the middle preset button to allow finger touch sensitivity. Drivers will be able to tell by touch where buttons #1 and #2

- are (to the left of the middle button with the bump) and likewise, buttons #4 and #5 are to the right.
- Replace the power button by moving it to the volume knob, the driver can turn the radio on by turning the volume knob up and turn it off by moving volume completely down until it clicks off. This allows us to move T.A. on/off toggle switch to the power button's position.
 - To make more efficient usage and placement of buttons, we can replace the R.D.S. button with the Set button and move the A.F. on/off toggle switch to the Set button's place. This allows controls to be next to each other that are functionally related.
 - Clarify the functions provided by the tuning knob: When in normal position it should select between stations (as a normal radio would). When pushed in it would click into place and switch between formats. The driver will then know by touch how to tune both stations and formats.
 - We believe listeners would like a choice of preset formats rather than only Rock, Country, Top 40, Urban, & Light, with only one pre programmable favorite button. We would replace buttons #1 - #5 preset formats and allow the driver to program a favorite format on each one.
 - Addition of a separate rewind and fast forward button to the tape player eliminates confusion of what button does what in which mode. Having all tape controls next to the tape player simplifies usage.
 - Add a T.A. annunciator light that would flash to alert the driver of a current broadcast of traffic information. In static testing fifty-one percent of subjects did not notice the MSG annunciator for at least two minutes, even when instructed to watch specifically for it. This is unacceptable for real time information transfer. The addition of a light cue allows the driver to know that a message is playing even when T.A. is off or when listening to another station that is not broadcasting traffic information. This could be a default to the KBEM signal, much like the billboards that flash on the highways to tell you to tune into 88.5 F.M. for traffic information.
 - The viewing screen is at the far right corner of the radio, farthest from the user. Design recommendations (p. 16-17) discussed luminance and contrast problems and the amount of distraction from the driving field of vision to read the display. Reconfiguration and repositioning of the control functions would allow the screen to be moved to a center location. Other possible modifications beyond the scope of this study include: a screen that may rotate and tilt towards the driver, or perhaps a detached display that may be moved to a convenient location that distracts less time from the driving field of vision.

- It is essential that default settings are considered in detail. If users become disorientated in the system by ambiguous defaults it will lead to greater distraction from the task of driving. Basically, the programmable features should remain constant unless deliberately changed by the user. Functions that are provided by the Delco receiver should be in an inactive state when the radio is switched on, this then allows the user to request functions as they require them (e.g.. traffic announcements interrupting the playback device.).
- Control knob size should be examined giving primary controls the largest or most easily distinguished size. The knobs for adjusting the output of the speakers left/right and front/back are probably seldom used but are relatively large and easy to find. In contrast the button for initiating RDS is small and surrounded by similarly sized buttons.

These suggestions need to be carefully studied to see what trade-offs are beneficial to the users. We would be remiss if we did not list some of the design problems that could be associated with these suggestions.

- These designs adds more buttons which could be and were assigned as dual function buttons before. We made a strong argument against dual function buttons, yet they reduce the number of buttons and controls present on the Delco receiver.
- Our designs require the driver to pre-program several buttons before driving. Hopefully, users should not try to program their favorite formats and favorite stations while driving.
- By eliminating the ST/PL function the user has to eject the tape or turn the system off to stop a tape. The previous design allowed the tape to be in place but toggled on/off. This is a very convenient function because when the tape was in the "Stop" mode the radio would operate normally. We eliminated it to reduce buttons and controls.
- The addition of a flashing T.A. annunciator light might annoy some users.

These are only possible solutions. Careful redesign would include consideration of driver preferences, pilot studies, tradeoff analysis, and use of independent evaluators.

LUMINANCE STUDY

Luminance is a good example to show how, even under static conditions, it may be difficult to operate the Delco receiver. At one extreme of ambient illuminance we think of night driving with perhaps only the light of whatever overhead lamps may be in the vicinity of the car plus the integral dashboard lighting including the light from the Delco device itself.

At the other extreme we must consider the ambient illuminance from direct sunlight. If we consider the luminance contrasts on the Delco receiver, including its display, we must think of the contrast for the button legends and the display characters on the display background. This latter condition must also be considered with bright light illuminating the display with its possible washouts, glare, and reflections. One further point to note in this introduction is the additional problems experienced by older drivers. Without considering any special pathology, such as cataracts, older drivers have marked losses in both dynamic visual acuity and contrast sensitivity. This means that older drivers need more light to detect and recognize objects. Objects in this sense can be the characters on the text display and the legends on the buttons. Older drivers decreased dynamic acuity is reflected in their inability to resolve detail in moving objects or alternatively when their gaze saccades across an object such as the panel on the Delco receiver. This is the kind of problems that must be evaluated in the initial design of these systems.

We reasoned that if drivers cannot adequately operate certain features of the Delco receiver under defined ambient environmental conditions, then they would not be able to do so when we imposed the additional task of simulated driving.

RESULTS AND RECOMMENDATIONS

The radio appears to require more and brighter integral lighting. All button labels are difficult to see especially those that are amber in color and when there is little (less than one foot candle) light. Likewise, the backlighted LCD-displayed messages are easily washed out by bright light (about 50 foot candles of direct illumination and 500 foot candles of diffuse light).

Six subjects free of ocular pathology could read the legends on the buttons down to an ambient illuminance of about one foot candle. For this measurement the subjects stared fixedly at the radio trying to read the legends. If the subjects were driving and could only glance at the display for brief intervals, the detection and recognition thresholds would no doubt increase.

With light shining directly on the display, the display became unreadable (washed out) at an illuminance of about 50 foot candles. When the light was diffuse, the display washed out at about 500 foot candles. Again, the threshold values would change if the subject was only glancing at the display while driving.

The Illuminance Engineering Society list minimums and maximums of 20 and 50 foot candles respectively to read text. Subjects were able to read the legends down to one foot candle due to the built in illuminance of the display. However, as we mentioned earlier the buttons cannot be distinguished, only the labels can be seen. Therefore, the display is readable

below the minimum value of the I.E.S., but needs increased contrast and illuminance to enhance operation. The values we measured show that at 50 footcandles the display is washed out and unreadable. This implies that the display will be unreadable before reaching the maximum illumination level. It should also be noted that direct sunlight can reach 500 foot candles. There are no provisions for shading the text screen (except for position in the dashboard and automobile layout), therefore the screen can be easily washed out in direct light. Indirect light which is typical of driving and having sun visors down or the normal layout of the car (the dash is usually shaded by itself), provides the ability to read the display up to this 500 foot candle level of direct sunlight. We infer that the display will not be washed out except at extremes when the sun is at the horizon shining directly on the display or in automobiles with high placement of the screen where there is less shading by the dashboard.

TRAINING

The other factor of concern in static testing is training time. If drivers must spend many hours with the owners manual to gain an understanding of the operation of the Delco receiver they may well forego the use of many of the radio's unique features. Below we describe a simple test to determine the level of understanding gained by subjects after one complete reading of the manual. (See Appendix D. for tests used).

Twenty subjects evenly divided between gender were given a memory location test, a knowledge quiz and asked to complete the task of setting the clock time. Both the memory test and the knowledge questions required ten responses.

RESULTS AND RECOMMENDATIONS

When given full access to the manual and no time limit (an open book test), ten subjects took an average of eighteen minutes to complete the memory and knowledge test. Subjects scored an average of 9.0 correct (out of 10 possible) for the memory portion and 7.5 on the knowledge test. Subjects should score a perfect score of ten when they have access and unlimited time to use the manual. It is clear from these results that the manual needs revisions to make the functions easier to understand and manual easier to read. On the task of resetting the clock the average time to complete this task was 3.75 minutes, with a range of 2.5 to 6.25 minutes.

Ten more subjects were given the three tasks after studying the manual for at least thirty minutes, but they were not allowed to use the manual during the test. Subjects were told to begin the test when they were ready after the initial thirty minutes. This retest produced much lower scores. Subjects completed the test in an average of 30 minutes. They scored an

average of 5.0 on the memory test and 5.5 on the knowledge quiz. The clock task took an average of 10.25 minutes with four subjects being unable to complete the task at all. This reaffirms the difficulty in operating the receiver with its complex tasks and its relatively new technology.

The results of the test have confirmed a number of potential problems. First, subjects had problems in understanding the manual. Time was not a factor for the groups to complete the tests, yet, subjects made errors in identifying controls on the interface. This may be due to poor explanation in the manual or inadequate labeling on the interface. The memory task showed that even though subjects had just spent over thirty minutes studying the manual and actively identifying functions and features on the radio they still had not become familiar with the radio. This suggests that in a driving situation they would be seeking visual information in order to operate the radio which would lead to significant distraction away from the task of driving. Finally, some task are so complex that operators would have to go step by step in the manual to complete them. Most operators are unwilling to spend the time to learn such complex tasks. We also assumed that few people read the instructions thoroughly, and this receiver requires very careful study of the instructions. Simplified manuals or reductions of controls steps will alleviate several of these concerns.

CHAPTER 3

TASK TWO:

SIMULATION STUDY

INTRODUCTION

The purpose of Task Two was to use what was learned in Task One and adapt it to an experimental study using the dynamic simulator at the HFRL. The objective of this task was to evaluate, in quantitative terms, how well the device conformed to its functional requirements with respect to performance. The reason for using the simulator was that if one merely judges, in a static environment, how difficult or easy it is to use the device, we miss the dynamics of the performance task as it occurs in a realistic driving environment. In determining the performance of the Delco system in simulation we will measure two effects:

Driving variables;

- RMS error measures (lane deviations);
- Steering measures;
- Speed control;

Assessment of ease of use and perceptions of simulation participants based on a questionnaire developed for obtaining such information.

In simulation we used the Delco receiver as it would be used on the Metropolitan area roadways without the inherent danger of actual untested on-road operation of this new technology. We employed a simulation of three segments of highway representative of three different roadways. We used a two lane roadway with bi-directional traffic, which represented any two way street. The second segment represented an exit/enter ramp where there was a single lane of traffic. The final segment was a two lane freeway or highway where the participants drove with traffic that was traveling at various speeds. We measured lane drift of the participants vehicle as well as we noted changes in speed, braking, and any non-typical driving behaviour. These results were statistically analyzed against a baseline of normal driving (no Delco receiver operation or message broadcasting.)

METHODS OF EVALUATION

The Dynamic Driving Simulator

In the simulation we measured the driving performance during use of the Delco receiver. To do this we employed the dynamic driving simulator at the HFRL (see Figure 4.) and used a simulated driving world.

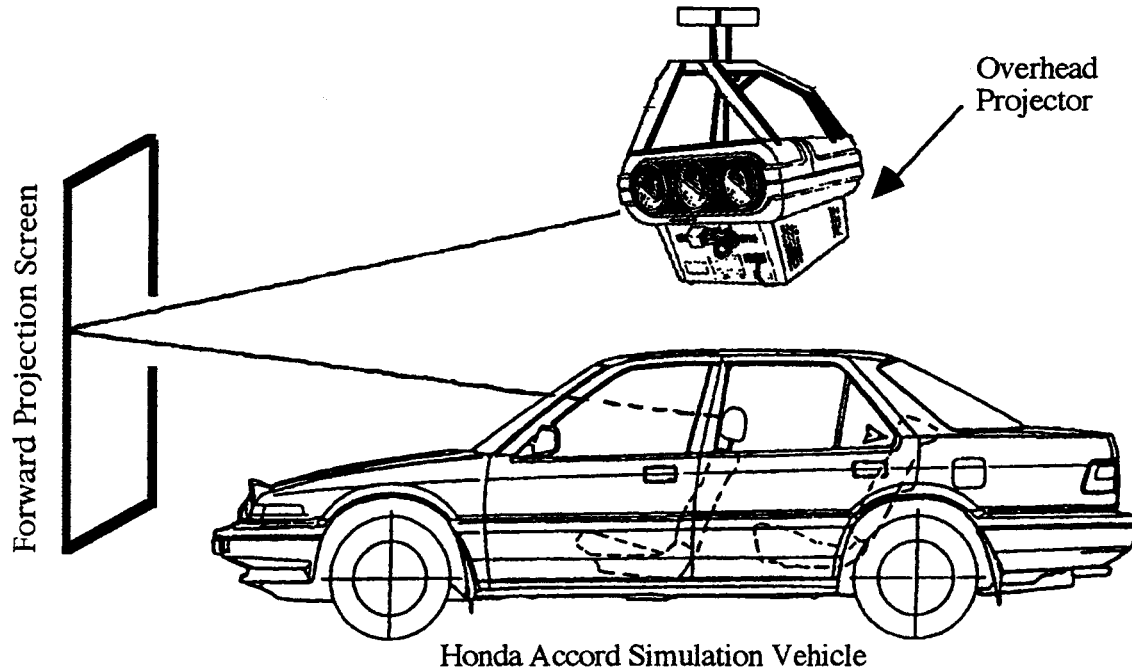

Figure 4. Side projection view of the simulation facility illustrating the 1990 Honda fixed-position vehicle, the overhead projection system, the screen orientation and driver visual viewing angle.

The HFRL's driving simulation facility is based upon a fixed-based Honda 1990 Accord. Inputs from the driver, in terms of accelerator and brake activation and steering are converted from analog to digital inputs. These are used as information which is fed to a computer model which approximates the equations of motion for the actual vehicle. Outputs from this model are then used to adjust the eye point of the driver in the environment in accord with the inputs given. The simulation changes to fit the orientation of the driver based on their driving actions. These changes are then displayed in real-time, constituting the dynamic driving world observed by the driver of the car.

This simulated driving world was programmed to be representative of the Twin Cities Metropolitan roadways, including driving with and against traffic and maneuvers typical of driving: merging into traffic, taking a left turn across traffic, and passing cars in front of the drivers. We called Segment One "Cedar Avenue" due to its representation of two lane bi-directional traffic. Segment Two we called "the Cross town" due to its East/West alignment and single directional traffic. The final segment, Segment Three, we referred to as "35W" due to its Southbound orientation and two lanes of like direction traffic, which is traveling at various speeds. These names are for illustration only and to give the drivers a semblance of the type of traffic they will encounter during simulation driving. (See Figure 5).

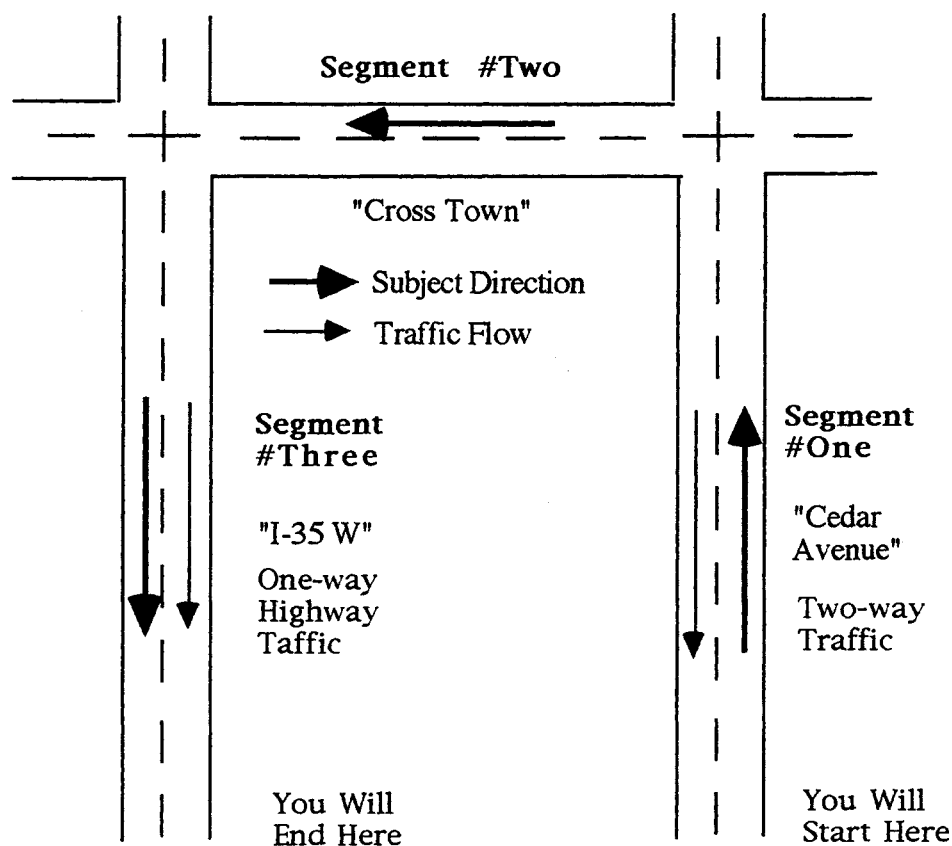

Figure 5. Simulated driving world containing three segments of differing driving conditions. You will note that drivers cross traffic at the end of Segment One and pass other vehicle on Segment Three.

The major variable studied is RMS (Root Mean Square) error, which is a measure of the vehicles position in relation to a center point. RMS error in this experiment was a function of the sampling rate and the frame rate of the simulation. This means that this variable is dependent upon the speed of the vehicle and the ability of the computing system to "redraw" the simulated world as seen by the driver. This is controlled by having participants drive at a constant 55 m.p.h. and designing a simulated world that the computer system can redraw faster than the human eye can perceive. RMS error was measured by determining the area of participants' vehicles deviation from the center line of the simulated roadway and was collected every tenth of a second. The center line perpendicular to the viewing screen that passed through the Honda Accord was calibrated as the zero line. This is compared to the center lane of the simulated world's roadway. We would then collect data based on the simulator vehicles movement from the center of the lane they were driving in compared to the center lane of the entire roadway. Other variables noted were deceleration / acceleration changes, driving performance degradations, and braking changes when stopping.

We used the XTAR hardware platform to generate the driving worlds. This is a medium level graphics generation system based in a 33MHz 386 PC that attaches to an Electrahome ECP-3000 projection system. Also contained in this loop is the actual vehicle itself, the Honda 1990 Accord and the associated analog to digital conversion peripherals that allow interactive driving responses on behalf of the experimental subject. As noted below, the software package used in the present project for the generation of objects for this system is the AUTOCAD design aid system. The XTAR system has been used extensively at HFRL for experiments in which look-ahead driving maneuvers predominate (e.g., left-turns). In terms of computational power, the XTAR system can calculate 2,000 flat-shaded polygons per second, where polygons are the currency of simulation fidelity. This represents a refresh or redraw rate of greater than thirty screens per second. This is equivalent to a motion picture which shows a frame rate of twenty-five frames per second

Object creation in XTAR is performed in a number of steps, as is illustrated in the following diagram: (Figure 6).

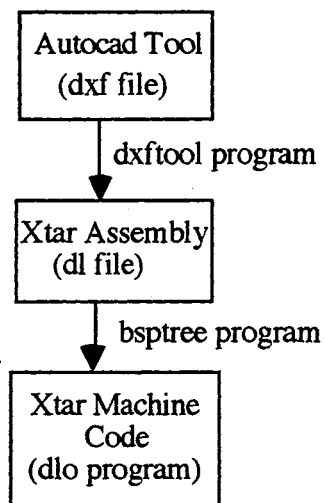

Figure 6. *Object creation procedure in the XTAR graphics simulation system.*

Once the AUTOCAD file for a object is created, the file is saved in the “dxf” format. XTAR has its own series of translation tools that convert this dxf file into a format that allows the object to be loaded at runtime.

To send messages we hardwired our simulation vehicle with the Delco radio antenna being attached directly to our signal generator and RE531 encoder. This meant that messages were sent directly to the car by the experimenter without being broadcast over the airwaves. The Delco receiver was tuned to 89.7 MHz which was our “broadcast frequency” and the Delco only received messages on this frequency. We downloaded ten representative

messages into the encoder and were able to randomly send any of these messages to the simulation vehicle at any time during the simulation trial. In this way we were able to control exactly which messages were sent and when they were sent. We established a random order of three messages to be sent during each trial. We also had three to four times during each segment in which to send messages which gave us ten different times during each trial that a message could be broadcast. This meant that based on a random order, participants would receive three messages with no two trials exactly the same as to when these three messages were sent. All three could be sent during segment one or one message could be sent during each of the three segments. In this way, participants could not anticipate when messages would be sent.

EXPERIMENTAL DESIGN

Our design was developed to study the extent of the features related to use of the Delco receiver, while at the same time studying potential impacts on traffic safety. We asked and answered three questions: (i). Could subjects successfully operate the Delco receiver while driving? (ii). Did use of the receiver interfere with performance of normal driving tasks? and (iii). Was performance jeopardized when both driving tasks and RDS tasks were done simultaneously? Clearly, these three tasks were inter-related. Our experiment needed to be set in an ecologically valid environment; our dynamic driving simulator. The variables had to provide representative measures of the performances relevant to driving and RDS use. The subjects needed to include both young and old drivers of both genders. Thus, our design would contain the elements necessary to draw valid and relevant conclusions from our data.

After establishing the simulation hardware, data collection procedures, and data inputs / outputs, the design of the experiment was determined. We wanted to use three different types of roadways (two way traffic, single lane, and highway) and this was established in our simulated world. This fit our desire to collect data based upon operation of the Delco receiver on these different roadways and conditions which are representative of Metro area driving.

In Task One we determined that: (i). The receiver is extremely difficult to operate even in a static state due to secondary functions and the long sequences of button presses. The main goal of this evaluation was to look at message transfer, so we chose a message reading sequence to be performed during simulated driving. We had determined in linkage and flow chart analysis that the task of reading a message was complex enough to differ from normal radio operation. This task involved detecting a message, pressing the RDS button, pressing the volume knob four times (while reading and comprehending messages), and all within the time constraint of five seconds between presses. We could not find a similar task on a normal receiver that was as complex. The closest was setting the clock or setting a new favorite

station but these tasks only take two button presses. (ii). The MSG annunciator light was difficult to notice. We wanted to measure how the performance of driving differed when using the device. If subjects did not notice that a message was broadcast, it would delay data collection or the driver might pass through an entire segment before noticing it. We elected to use the playback device interrupt as this would be an absolute indication that a message was broadcast. When we sent a message, the participant's cassette tape would stop playing and they would hear traffic radio. This would simulate the condition where drivers were listening to a tape, a message was transmitted by TMC via KBEM radio, the tape would stop and the driver would know there was a message. We felt that this was necessary due to a large amount of Task One subjects (fifty-one percent) not noticing when the MSG annunciator would light. This allowed us to control when participants would know that a message was being sent. This meant, instead of an arbitrary time window of noticing a small annunciator light, all subjects received the same audio clue (tape stopping) and would know exactly that a message was to be read. (iii). We wanted the best conditions for reading the message display. Luminance testing proved that there is adequate illuminance from the display to read the screen at low light levels. The simulator is a projection system operated in a dark room. Hence, keeping the simulator vehicle dark on the inside (no dome light or external lighting) allowed adequate contrast for reading the illuminated screen. (iv). Finally, Task One proved that learning how to use the device was difficult. To reduce any learning effect, all subjects were trained only on operating the text screen and were given ample time to familiarize themselves with the radio and the simulator. Learning effects occur if inadequate training is used and participants actually improve their performance during a trial because they are gaining practical (hands-on) experience during the experiment. All participants were thoroughly trained and given time to ask any questions before starting trials.

To increase the complexity and realism present in the simulation we had the participants perform two driving maneuvers in addition to their normal driving on the roadway segments. Drivers performed their message reading tasks while performing two driving maneuvers; a left-hand turn and a passing task (lane change / pass vehicle). Each of these maneuvers requires the drivers' attention to be directed not only to control of the path of the vehicle but to the movement of surrounding traffic. The maneuvers are more difficult than simply maintaining the car in-lane on a long straight stretch of highway. These maneuvers are, however, typical of everyday driving for most participants. Ordinary driving, as represented by the left-turn and passing maneuvers, require drivers to attend to the path of their own vehicle and at least the path of one other vehicle. Drivers must make predictions about the near-future positions of their own and other vehicles based primarily on estimates of the velocity vectors (how fast is that car approaching me?) . If drivers suspect that another

vehicle is moving fast enough to interfere with these maneuvers, they must adjust their own speed and/or direction to avoid the anticipated collision. This is, of course, a great oversimplification of the magnitude of the problems faced on a moment-to-moment basis by urban drivers. The amount of attention we, as drivers, can devote to solving this continuous problem is finite. Attention does not expand as the need for increasing our attention to different objects grows. In these experiments we will be adding Delco operation to the ever-present guidance and navigation task. Thus, operating the Delco receiver is one more demand on our limited supply of attention.

EXPERIMENT DESCRIPTION

Participants began the simulation by accelerating in a northerly direction on a two-lane street. In the other lane, groups of south-bound cars were approaching. Speeds of these groups of cars varied as did the spacing between the cars within a group of cars. After five miles of driving against traffic the participants reached a cross-street. There was a stop sign on only the participants' side. They had been instructed to make a left turn at this intersection as soon as there was a sufficiently large gap in the approaching southbound traffic. The participants then waited for the necessary gap in south-bound traffic. Drivers were instructed to initiate the left turn at the earliest opportunity. That is, to proceed through the shortest duration gap between cars that would not lead to a collision. (See Figure 7).

Thus the drivers were required to divide their attention between on-coming traffic, and maintaining the car in a coordinated left turn. This division of attention is an important part of driving and the chief reason why so many accidents occur during left turns.

After turning the participants drove on a two mile stretch of simulated double lane road with no traffic. This was similar to driving on an entrance ramp or two lane trunk road where the traffic would be moving with the driver towards a highway. We used no traffic on this segment as a control to establish clear baselines where drivers had to concentrate only on driving on the road and attending to messages. At the end of this segment there was a turn and merge into highway traffic.

This final segment was a five miles, driving southbound with traffic of varying speeds. This was to emulate highway driving. To add complexity to this segment we employed a passing maneuver based on whether cars were directly in front of the participant after the merge or if the participants caught up to slower cars later in the segment. The lane-changing portion (Figure 7.) began with the driver proceeding south in the right-most lane of a multi-lane highway. Ahead were vehicles which were traveling more slowly than the participant. The participants were instructed to overtake the cars. When the subject's car was close behind the slower vehicle, the subjects were instructed to move to the lane to their left and pass the

car after first determining that it was safe to change lanes and pass. As in the left-turn experiment, messages were received on the Delco receiver during this task.

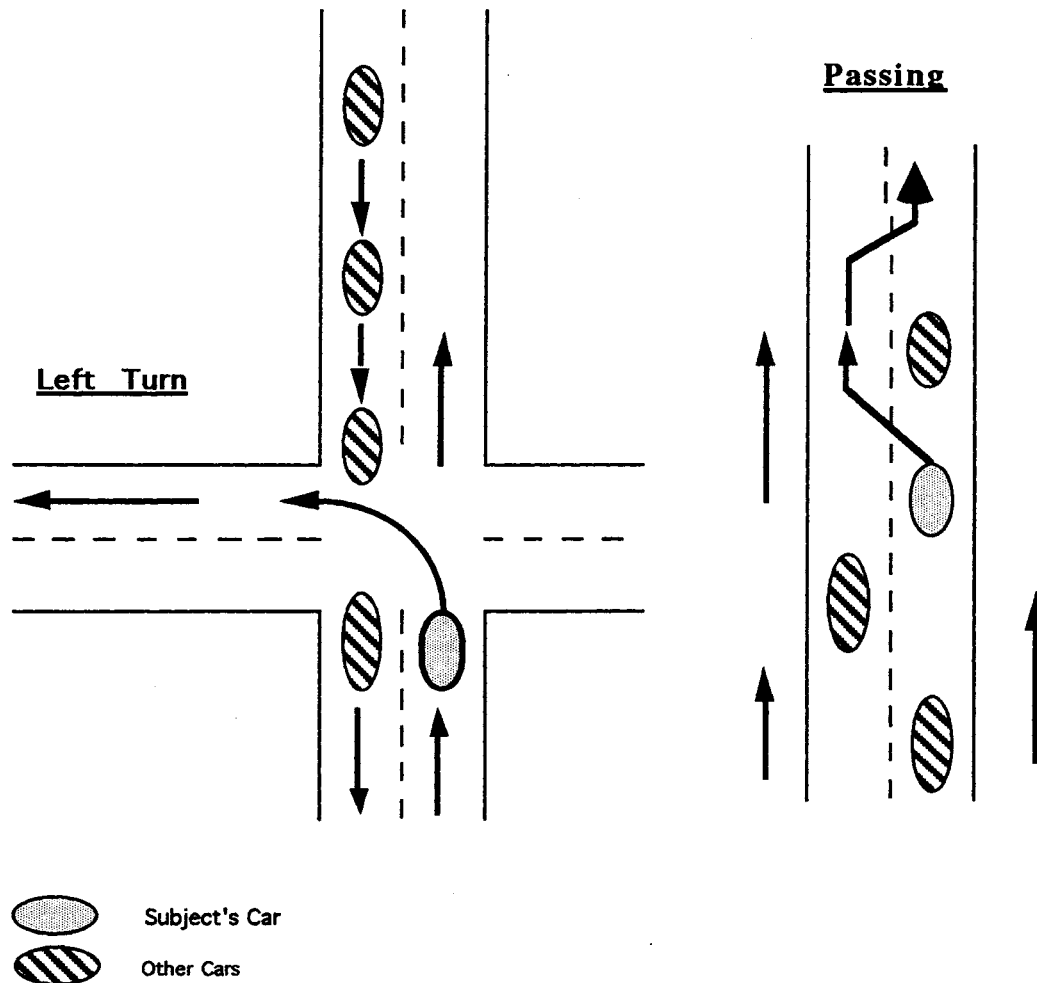

Figure 7. *Left turn and passing maneuvers required on Segments One and Three.*

PARTICIPANTS

There were thirty-eight data trials, using eight older subjects (four male, four female) and thirty younger subjects with the younger subjects further divided into sixteen female and fourteen male participants.

Each subject read the Instructions for Participants packet. (See Appendix E). The subjects then chose a musical tape to listen to in the car. Questions were answered by the experimenter about the Delco receiver before the subject was in the car and while the subject was sitting in the car during the practice trial. Before the real trial began, the subjects drove the car until they felt comfortable. Practice messages were also sent during this time. Subjects made a left

turn during the practice trial and when they felt comfortable with simulated driving they told the experimenter when they were ready for an actual trial. We used the Delco system's TrafficA function which allowed for tape interruption when messages were being broadcast. By using the tape interruption function we were assured of participant's noticing that a message was sent. The tape of their selected music would stop entirely. When a message was sent the subject read it outloud to us. We then asked the subject to repeat the message. Subjects performed two trials and were reminded to drive 55 m.p.h. Between the trials the subject could take a short break.

After the two trials were finished each subject filled out a post-simulation questionnaire (Appendix F.). This questionnaire was design to elicit responses to ease of use, likes and dislikes, practicality, and simulator performance. These help us determine a subjective feeling about the Delco receiver and the new technology of delivering traffic information. Completed questionnaires are included in the Addendum to this document.

FINDINGS / RESULTS

The simulation study was designed to allow statistical analysis comparing RMS error collected for normal baseline driving with driving during Delco receiver operation. These two conditions were paired for analysis and then compared in two ways. This translates into a driving performance change where we measured a "baseline" driving state and compared it to a "message broadcast" driving state. We used the data collected on each pair and compared their mean values (average value over time) and variation (comparison of the range of values over time). We found that all drivers had statistically significant degradations in driving performance while operating the device during message broadcast. The complete data collected is included in the Addendum to this document. We used both measures of analysis because two sets of data can have a large spread or a small spread in range but still have the same mean. (see Figure 8).

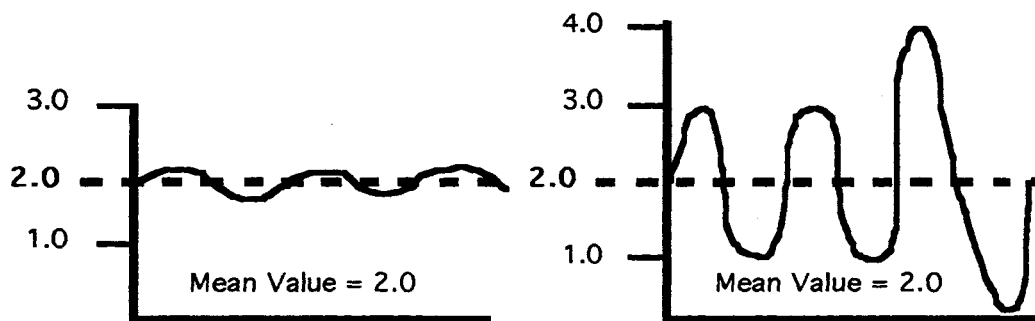

Figure 8. *Two graphs with high variation in data but equal means. They both have equal means of 2.0 but large differences in variation. Taken form Glass & Hopkins, 1984. pp.41 & 332.*

When we collected data it was converted into graphical and tabular representations. The tabular data sheet included the time that messages were broadcast by the experimenter. This became our starting point for data analysis. We compared this to a similar length of time when the driver was receiving no messages (baseline driving). The graphical data allowed us to visualize the path of the car from the drivers perspective. (See Figure 9). The graphs have a zero line parallel to an X axis which is the center point of the car as it travels down the simulated road. As the car's path is adjusted by the driver during normal operation, the center of the car moves slightly to the left and right. During message broadcasts these deviation are magnified due to the driver's divided attention.

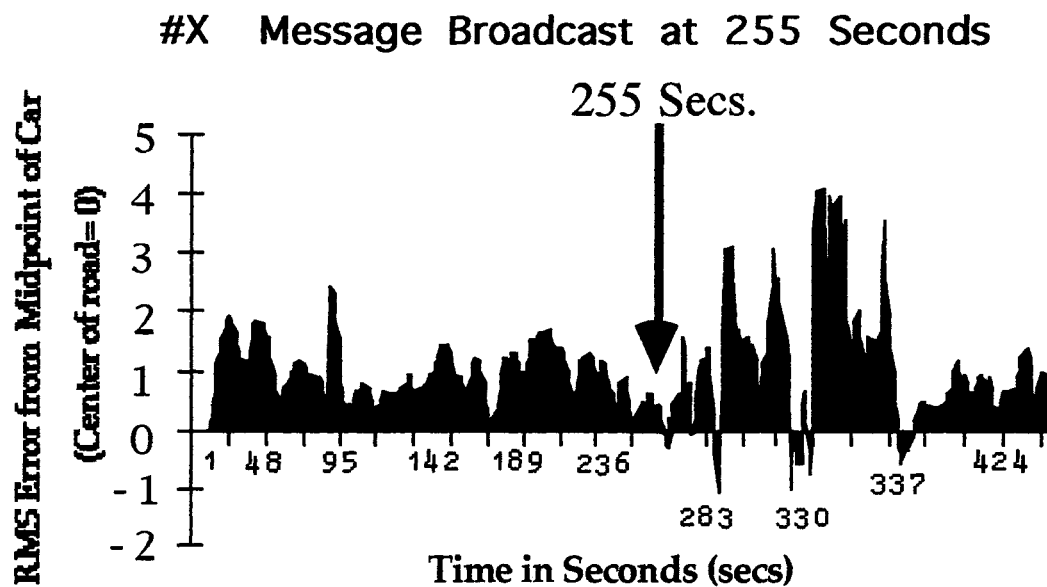

Figure 9. *Representative data graph for one participant. Note change in driving pattern when a message is broadcast and the Delco receiver is operated. All subject data graphs are included in the Addendum to this document.*

The subjects are reading text messages, pushing buttons, and trying to drive correctly. This requires tradeoffs where the driver pays less attention to driving while reading messages and vice versa.

In this graph the participant did not keep their car exactly in the middle of the road. This is a common occurrence for all drivers. We all have our own comfort level or margin of closeness for how near we allow our car to get to the center line. Several participants in this study left wide margins from the center, while others drove very close to it. This variation is controlled by the fact that the same level of comfort is maintained in all situations (even when operating the Delco receiver) as participants stabilized their deviations.

There were three messages broadcast to each subject and the times that they were sent was randomized over ten time periods. This necessitated that certain subjects receive two messages during a certain segment and none during others. We have included only those graphs in the addendum that included messages being broadcast. This implies that Subject #1's data might have been one message during segment #2 and two messages during segment #3. Likewise, Subject #24 may have received all three messages during the first segment due to randomization. It will not always be one message in each of the three segments.

In normal driving we have a small amount of deviation within our own lane. While operating the Delco system we noted the drivers varied to a greater extent than normal within the lane. Acceleration, deceleration, and braking changes were also noted during the trials.

INTERPRETATION OF RESULTS

Statistical analysis included means, standard deviations, T-tests to compare these means, and regression (F-tests) to test for significant variation between the baseline measurements and the messages. (Glass & Hopkins, 1984). We needed to establish a way to calculate the comparison between means and as we explained earlier this was accomplished by pairing baseline and Delco operational segments of time. By using the data graphs, we calculated the average time for a driver to return to baseline after message broadcast, as 96.4 seconds. Therefore, we used 100 seconds of baseline driving and 100 seconds after message broadcast as our data pairs. This allows us to ensure that when we measure performance during driving we include all of the effects caused by reading the text screens. When drivers notice they are drifting there are several adjustments that drivers will make to return to their normal driving patterns. This is similar to someone driving on a road where a wind gust hits them. They swerve a little with the wind, and steer back and forth until their car is stable again. In much the same way drivers noticed that they were moving across the road when operating the Delco receiver and they adjusted and readjusted until they had returned to baseline driving. From our data collection we know that these adjustment take at least 96 seconds on average, therefore, statistically using 100 seconds of pre and post message broadcast would include a normal baseline and all adjustments when using the Delco receiver. This way we measure the entire message broadcast segment, because the driver will have returned to baseline readings in 100 seconds. This also allows us to measure the entire variation of the data. We calculate their driving variation over a large amount of time (100 seconds) and can be certain to include all of the adjustments required to return to normal baseline driving. We can also feel certain to have an accurate measure of the variation from normal baseline driving.

SIMULATION TEST RESULTS

Statistical analysis of the data revealed significant differences (average probability below 0.05 percent) for all subjects in all driving segments. This meant that in all cases (except one minor exception) all measures of means and variation were significantly different between normal driving and Delco receiver operation. Statistical analysis uses 0.05 probability (1 out of 20) as the measure of when data can be established as statistically sound and can be generalized to large populations. The data we collected suggests that driving performance will be degraded by the operation of the Delco receiver.

The following chart (Table 2) is tabulated from the data collected for each subject. Each participant is listed by subject number and then data is tabulated by the probabilities found when calculating t-tests of means and F-tests of variation. Each subject will have two or three messages with data. If a subject has only two messages listed this is because the third message was broadcast during the turns when data was not collected by the computer systems. This will be listed as "No Data" in the table. During these times we recorded paper and pencil observations as to driving behaviour and performance. (Table 3.) These measures included when participants were driving through the left turn maneuver and when merging into traffic. Because these two conditions require turning, there can be no RMS error calculations made. Therefore, when messages were broadcast at or during the left turn (segment one) or the merging task (segment two to three) a second experimenter noted any driving performance changes. These included: not stopping at the stop sign accurately, failure to slow for the merging task, misjudging the left turn (causing collisions with on-coming traffic), taking extra wide turns, missing the turns, or ignoring messages until after completing maneuvers.

The t-test is a comparison measure of the means between the baseline and the message broadcast data. The probability value for the t-test should be less than 0.05 to be statistically significant. This is chosen to allow only a 5% (1 in 20) chance for the magnitude of the difference between the means to be due to chance. (Glass & Hopkins, 1984). We note that differences between the means for the majority of subjects are highly significant in the 0.001 - 0.0001 range (Table 2). Subject #5 message #2 represents the only non-significant finding (0.0565) although this value would be considered marginal and generally acceptance as significant. Several other subjects, #3, #18, #35, and #39, are close to 0.05 during at least one segment. However, in all cases these subjects have highly significant t-tests during their other messages.

TABLE 2. Summary data for each subject's T-tests and F-tests.

Subject Number	T-Test			F-Test		
	Mess. 1	Mess. 2	Mess. 3	Mess. 1	Mess. 2	Mess. 3
1	0.0001	0.007	0.0001	0.0458	0.01347	0.0023
2	0.0008	0.0001	0.0084	0.0487	0.0001	0.0001
3	0.0001	0.0486	0.0384	0.0378	0.0028	0.0357
4	0.0001	0.0009	0.0291	0.0003	0.0001	0.0022
5	0.0001	0.5648	0.0063	0.0097	0.0002	0.035
6	0.0001	0.0001	0.0001	0.0046	0.0001	0.0341
7	0.0001	0.0001	0.0277	0.046	0.0142	0.0001
8	0.0001	0.0001	0.0001	0.0308	0.0001	0.0379
9	0.0002	0.0082	0.0001	0.0194	0.0479	0.0233
10	0.0016	0.0001	0.0001	0.0027	0.0366	0.0001
11	0.0001	0.0337	No Data	0.0326	0.0022	No Data
12	0.0001	0.0001	0.0001	0.0335	0.0034	0.0082
13	0.0001	0.0001	No Data	0.0494	0.0214	No Data
14	0.0009	0.0455	0.0001	0.0093	0.0001	0.0366
15	0.044	0.0001	0.0054	0.0001	0.0498	0.0009
16	0.0001	0.0001	0.0001	0.0478	0.0402	0.0011
17	0.0001	0.0001	0.0001	0.0006	0.0488	0.048
18	0.0485	0.0001	0.0485	0.0003	0.0481	0.0001
19	0.0001	0.0001	0.0001	0.0496	0.0001	0.0059
20	0.0001	0.0001	0.0005	0.0353	0.0052	0.0396
23	0.0001	0.0001	0.0004	0.048	0.0448	0.0483
24	0.0001	0.0001	0.0001	0.0474	0.0439	0.0001
25	0.0001	0.0001	0.0001	0.0465	0.015	0.0002
26	0.0001	0.0001	0.0001	0.0075	0.0015	0.0033
27	0.0007	0.036	No Data	0.0001	0.0075	No Data
28	0.0001	0.0041	0.0021	0.0313	0.0494	0.0467
31	0.0225	0.0036	0.0001	0.0421	0.0313	0.0406
32	0.0392	0.0001	0.0001	0.0001	0.0001	0.0024
33	0.0001	0.0001	0.0001	0.0465	0.0329	0.0001
34	0.0222	0.0002	0.0272	0.0283	0.0077	0.013
35	0.0491	0.0461	No Data	0.0356	0.0493	No Data
36	0.0461	0.0166	0.0391	0.002	0.0387	0.0382
37	0.0078	0.0023	0.0001	0.0468	0.042	0.0317
38	0.0001	0.0462	0.0002	0.0001	0.046	0.0025
39	0.0001	0.0001	0.0487	0.0483	0.0357	0.0427
40	0.0001	0.0001	0.0001	0.046	0.0481	0.0001
41	0.0001	0.0001	0.0163	0.0193	0.0234	0.0357
42	0.0049	0.0001	0.0023	0.022	0.0111	0.0052

Summary data of simulation testing.

Marginally significant or non-significant results are in bold type.

TABLE 3. Observations Made During Periods Of No Data Collection.

Subject #	Observed driving behavior.
Subject # 4	While reading message in segment three, the participant did not notice that car in front had slowed. The participant's car approached close enough for a possible rear-end accident before they reduced speed.
Subject #11	Failed to stop at stop sign in segment one. Participant was reading third line of text and did not start to slow until within 100 feet of stop sign. Participant "stood on brakes" but still went through intersection.
Subject #13	Misjudged left hand turn and pulled into grass making a wide turn.
Subject #17	Received message one minute before merging task and ignored message until task was completed.
Subject #27	In attempting to operate Delco receiver at stop sign, participant misjudged gap in on-coming cars and would have caused a collision in real test.
Subject #35	Participant received message one and half minutes before stop sign and instead of braking at the sign, they completed a simple merging maneuver.

The F-test measures the regression of means and is a measure of variation of the data. The simulation study should have higher variation when messages are being broadcast due to the exceptional amount of time the drivers take their eyes away from the road. In the graph example (Figure 9.) the radical variation change in driving behaviour after message broadcast is shown. The normal drifting pattern seen with the baseline becomes a jagged, rapid pattern. Again the F-test probability should be less than 0.05 to be significant. All subjects tested were significant over all segments. Several subjects, #2, 13, 17, 19, 28, and 35, had barely significant results but again they usually have other highly significant data in other segments.

Analysis was completed between, age groups, gender, and each subject against all segments driven. Age and gender provided no significant results, meaning that there were no differences between older / younger or male / female drivers in this study. Subject against segment driven (Table 4.) provided us with an indication whether drivers learned or improved as they operated the device. If there is a significant difference between trials or between segments then the subjects have not been trained adequately and early data collection may not be valid. All subjects had no significant differences between trials or segments. We conclude that our data collection was statistically valid and reliable.

TABLE 4. Comparisons Of Each Segment Verses Each Other.

One Factor ANOVA-Repeated Measures for Segments #1 - #3 and verses each other.

Group:	Count:	Mean:	Std. Dev.:	Std. Error:
Seg. #1	10	.702	.864	.273
Seg. #2	10	.86	.894	.283
Seg. #3	10	.858	.879	.278

Comparison:	Mean Diff.:	Fisher PLSD:	Scheffe F-test:	Dunnett t:
Seg. #1 vs. Seg. #2	-.157	.599	.152	.552
Seg. #1 vs. Seg. #3	-.155	.599	.149	.546
Seg. #2 vs. Seg. #3	.002	.599	1.780E-5	.006

Significant findings are marked with an *. (None are significant.)

Observations taken during trials revealed that all subjects decelerated during message reading. As they read messages aloud, the speed they were traveling decreased by 5 - 10 %. Reading the messages aloud reinforced the messages to the drivers. This procedure assured us that the drivers comprehended the meaning of the messages rather than just glancing at them. This device would only be effective if drivers actually read and understood the messages. Several subjects received messages during stopping maneuvers, when crossing traffic, and during traffic merging. All subjects with this scenario reacted in atypical ways, either braking late, or taking wider than normal turns as they tried to operate the Delco prototype. It is our conclusion that normal drivers should wait to operate the device only after such maneuvers were completed, however, experience tells us that drivers do not always think this way .

A practical way to report our findings is to convert the lane drift noted in the variation measures to actual measures of physical distance. The variations were averaged for each subject and converted by the scale factor used in the computation of the simulated world. The average lane drift in meters during baseline was 0.299 meters or about one foot. During message broadcast and Delco operation the distance was 0.67 meters. Subjects averaged an extra third of a meter drift in each direction during device operation. As we noted earlier this is atypical and unsafe.

Several drivers (four) ejected the cassette tapes because in the dim lighting of the simulator they felt that the label for the RDS button would be above the button. The label is actually on the button itself. The normal way that controls are labelled is usually for the label

to be above the control or button. Our subjects pressed below the label and accidentally pressed both the RDS button and the Eject button. This confirmed the prediction from the static analysis of the Delco device.

Overall, this data bears out our initial functional analysis assessment that this prototype device requires far too much distraction away from driving to be used during operation of a vehicle. This was a best case test and driving performance was still degraded. It is our opinion that driving performance would degrade even further if we were to require the subjects to constantly look down at the device to see a tiny annunciator light. We are using the best indicator that messages are being broadcast, (the subject's music is stopped completely), to indicate that a message is being broadcast, and our data is still highly significant. Even if the subjects were to spot check the device quickly (as in glancing down at the speedometer) they would still be adding another burden to their driving and attention.

RECOMMENDATION

This device should not be operated as it is while driving an automobile. The suggestions for design changes noted in Task One and the principles of design discussed should be used in future designs of this prototype. It is our belief that all functions except reading text messages should be completed before driving and the task of reading messages during driving needs to be simplified. This device shows promise for delivery of traffic information but it requires modifications if it is to be used effectively while driving.

POST-SIMULATION QUESTIONNAIRES

The survey was divided into several sections which aimed at trying to find specific areas of interest. The first area was Usage Patterns. Here we tried to assess how often participants used their normal radio, and if they listened for traffic announcements on a regular basis. The second section focused on Learning to Use the Delco Receiver. Here we tried to assess if the participants truly understood how to operate the radio and drive the simulated car. This helps us in developing better testing procedures and can be used to improve instruction and training. Next we assessed the Procedures and Functions of the Delco Receiver. We want to know how difficult or easy the receiver is to operate from the participants standpoint. We also want to learn how the participants felt as to their own attention to driving and to the receiver. The fourth section had questions on Clarity and Visibility. We want to know if participants can not read the messages due to lighting conditions or could not understand the messages due to abbreviations. Finally we asked about Overall Evaluation. Here we ask them to compare a radio with a text screen like the one they have just used to listening to radio traffic

announcements. We also ask them which type of information they would trust, text messages or radio announcements. Finally we asked for comments on the driving simulator and anything else they wanted mention on their entire experience with the receiver.

A copy of the post simulation questionnaire and the responses by subjects are included in the Appendixes for further reference.

FINDINGS

The subjects were asked what percent of the time the radio was on when they drove their car every day. The average response was 91% of the time. However, only 38% of the subjects reported that they listened to the radio specifically for traffic announcements.

The Delco receiver was rated as being normal to operate on a scale where choices ranged from easy to normal to difficult. This implies that the majority of subjects felt it was not much harder than operating a normal radio. We should note that participants were only taught one task, not all of the features available on the radio. In contrast, only 23% of the participants felt that they were able to keep their eyes on the road the same amount of time that they do when they normally drive and operate a radio. This implies that they felt they were looking down at and concentrating on the radio to a much greater extent than normal. This is expected due to the time it takes to look down and read messages. On a similar question subjects felt that their attention was spread too thinly and felt that the radio distracted them from driving "occasionally to half the time". During the Clarity section several participants found it hard to understand some of the abbreviations that were used. Also, some said it was hard to distinguish between N and W on the radio.

In asking participants if they would buy a receiver like the Delco if its only extra function was to show traffic information on a screen, participants replied at a rate of 85% against buying this type of receiver for that function. Interestingly, over half said that they would believe the radio screen for giving accurate traffic information over a radio announcement. This contradicted the finding that only one third said they would pay more attention to the radio screen over the radio station announcement. This means they are willing to believe what they read over what they hear on a radio, but are not convinced that they would use the screen as often as listening for occasional traffic messages.

The complete survey and individual response breakdown are included in the Appendix and Addendum to this document. (See Appendix F.) The above findings should be evaluated in the context that subjects performed one of the easiest operations provided by the Delco receiver.

RECOMMENDATION

This survey indicates that it would be difficult to break the link between driver and traffic announcements. It might be advantageous for this type of technology to be promoted as an adjunct to normal radio and not as an alternative. Further evaluation on subjective opinion is extremely important and for the following Trilogy projects, end-user opinion should be surveyed periodically to judge the progression from novice to expert user and to gauge the true needs and wants of the user.

CHAPTER 4

TASK THREE:

ON-ROAD VALIDATION STUDY

INTRODUCTION

In Task Three it was our goal to establish that our on-road lab car could be hardwired with the Delco receiver, the signal generator, and the encoder so that messages could be directly sent to the car. We could then send messages without broadcasting over the airwaves. Further, we wished to validate our finding in simulation by using an on-road evaluation. In our original task plans we were to conduct a test track and an open road evaluation of the devices for tasks three and four. After consideration, it was decided to establish an on-road validation and a new task four (Chapter Five). Mn/DOT had tested the Delco receiver in fleet vehicles and it was their main goal to establish that this technology could be set up and real time messages could be assembled, sent and received. We continued in that spirit by conducting a small study in our on-road vehicle.

METHODS OF EVALUATION

We mounted the Delco prototype receiver in the HFRL car and hardwired the antennae to our signal generator and encoder in the trunk of the car. An experimenter sat in the back seat and sent messages at random intervals via the encoder to the Delco receiver while a participant drove on-road. Participants were limited to University employees due to insurance restrictions when using the Universities Fleet Service automobiles. Participants were volunteers from the University Psychology subject pool and Laboratory employees. This was a limited budget study to determine the ability to verify simulation results, therefore, four participants were chosen. These participants included a 27 year old male, a 28 year old female, a 40 year old male, and a 63 year old male. This was done to attempt to balance this limited study. Drivers were asked to operate the Delco device in the exact same way that it was tested in simulation study (Task Two). The drivers were presented with three different message at different times during a ten minute drive. The course driven was at the University of Minnesota following East River Road which is two way traffic. The subjects drove to a stop light, turned left onto a short street, completed another left turn onto a road which curved back to East River Road. The subject would turn right onto East River Road and return to their starting point. (See Figure 10.)

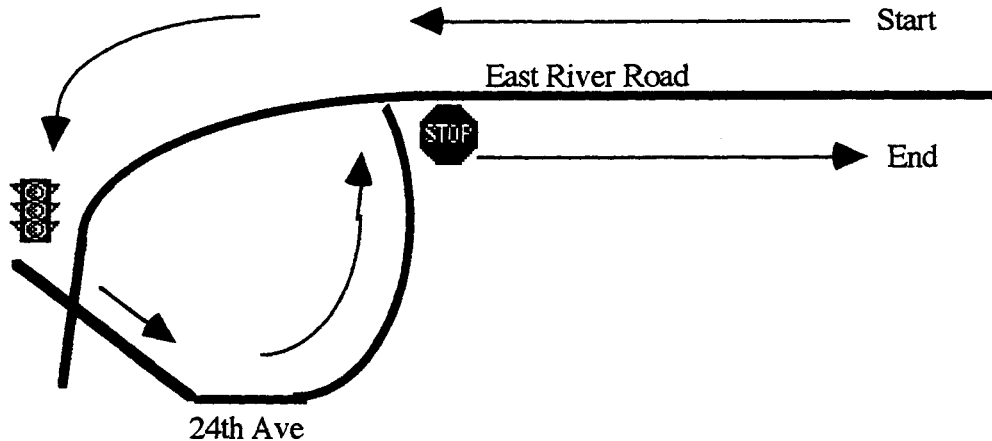

Figure 10. *Route driven by on-road participants.*

An experimenter riding in the front seat with the participants noted any atypical driving behavior, speed changes, or lane deviations. The main variable studied was driving performance while operating the device. The experimenter had to note and subjectively assess normal driving and then make note of any abnormal performance. This is an imperfect system as we have no computerized data collection of RMS error or speed changes as we do in the simulator. However, this was a valid way to note the findings we were looking for in comparison to the simulation study. We had seen performance degradations in simulation that were highly noticeable to the naked eye. We inferred that these degradations would transfer to on road driving, especially for relative novices at Delco receiver operation. As an extra measure a video tape recorder was installed in the rear of the car giving a view of the back of the participant's head, the road in front, the Delco receiver, and any controls or speedometers visible. We hoped that this video tape would help in the estimation of head down time and any control operation difficulties. To estimate head down time we hoped to calculate the time spent turned down looking at the device. This was to be established by the driver's reading the messages out loud. We inferred that if a driver was reading a message out loud to us, they were looking down at the screen and reading it. The video is inconclusive due to difficulty in assessing direct eye gaze. The driver can appear to be glancing down at the display (head turned down towards it) but in actuality they may be turned down towards the screen while they look out the windshield. The video tape was used to confirm observations of the examiner when possible but could not provide sufficient detailed information to add to the examiner's data. An overview of the on-road set-up is shown in Figure 11.

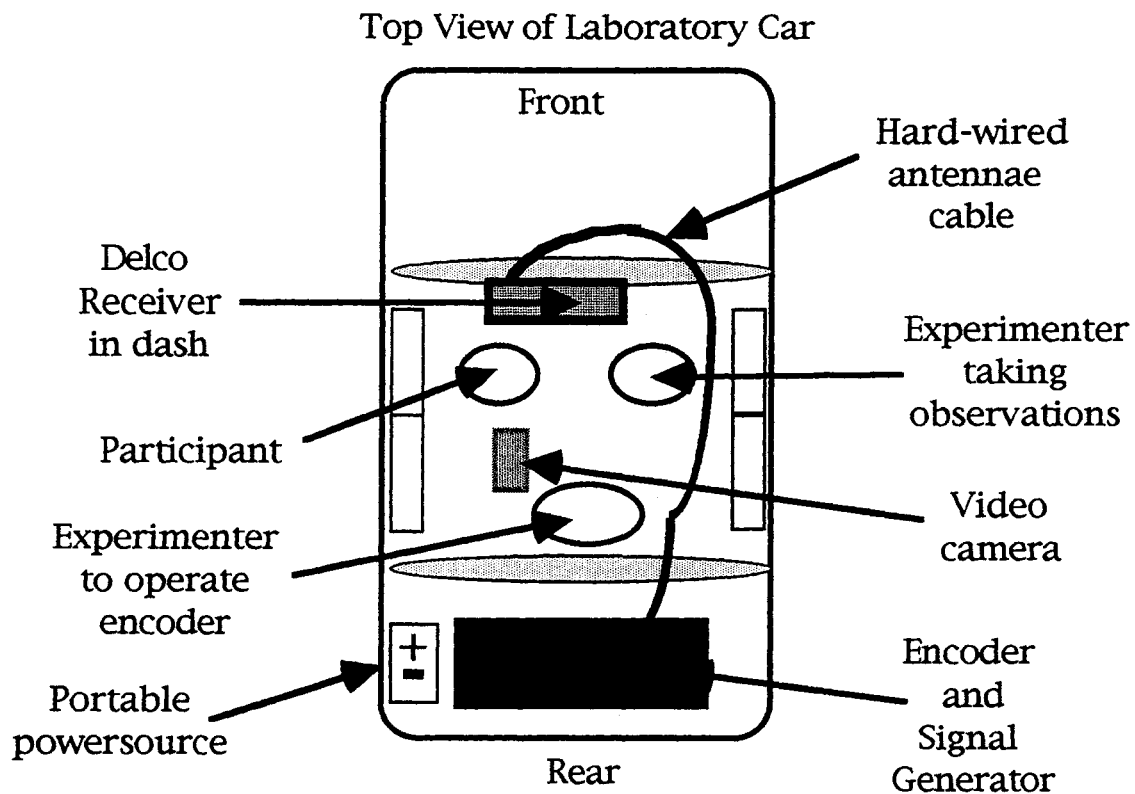

Figure 11. HFRL laboratory car set-up for on-road testing.

FINDINGS

On-road study confirmed our simulation results. Four subjects were tested using the HFRL car equipped with the Delco broadcast system and a video camera. An experimenter sitting in the passenger seat recorded all observations. While driving the laboratory car during message broadcast all subjects slowed 5-10 m.p.h. and exhibited minor lane drift. Two subjects drifted across the center lane slightly into the oncoming traffic lane and corrected back when they realized they were drifting. All had problems operating the device because they were reluctant to look down at the device for extended periods of time. All subjects spent several seconds looking down at the device while trying to drive and operate the functions. All subjects expressed displeasure with the difficulty in scrolling and reading the text messages. This was a factor in their reluctance to look down at the radio four times and read four screens of text. The Post-Simulation Survey was administered to these subjects and results revealed strong dissatisfaction towards the need to look down at the radio with as much frequency as was required. All four subjects expressed displeasure that they had to hit a button four times and look down at the screen four times to read a simple message. Individual results from the observer are listed in Table 5.

TABLE 5. Individual Observations.

Subject #	Observations during message broadcast
Subject One	Subject slowed down considerably (10 mph) and swerved slightly. Subject did not realize a message had been sent once, was told after one minute by experimenter. In order to read message the subject often fixed on radio for long periods (over three seconds) to read entire screen.
Subject Two	Had problems activating RDS button and message. Reduced speed by 5-10 mph and drifted into oncoming traffic slightly. Slowed considerably when reading message and when approaching cars in front of driver as if worried about rear end collision.
Subject Three	Reduced speed by 7 mph when reading messages crossed center lane slightly during messages. Subject also braked harder than normal when approaching a car in front.
Subject Four	Slowed 10 mph when reading messages then increased speed by 15 mph after completing Delco operation. Subject drifted in both directions when reading messages. Moved head up and down constantly when reading as though nervous when glancing down at the receiver.

RECOMMENDATIONS

We would recommend for future on-road validations that our lab car be fitted with some form of acceleration / deceleration monitor or lane monitoring to provide statistical validity to these tests. Computing of data would provide much stronger validity to the simulation findings.

The video taping did not provide any further information other than noting the same observations that the experimenter made. Its use for head down time is dependent upon knowing if the subject is actually looking down at the radio which is hard to determine from a rear view. Either a front mounted camera or a two camera set-up might provide better information. However, even front mounted cameras do not tell us if a person's attention is focused on the device. Using a verbal reading of the messages helped proved when subjects were attending to the device.

We feel that this study further enhances our conclusion of Tasks One and Two that further design changes be implemented before using this device in on-road vehicles.

CHAPTER 5
TASK FOUR:
PILOT STUDY OF CRUSADER SOFTWARE AND OPERATORS

INTRODUCTION

The previous three tasks examined the Delco receiver in detail. The following two tasks were established to assess the architecture used in delivery of the messages to the receiver. The Delco device used a simple PC program to assemble text messages for broadcast. The next generation of devices to be used in the Trilogy project require a more advanced software package to assemble messages. It was agreed that a pilot study of this Software and operators in the TMC Control Room would be beneficial. The TMC Control Room is where the next software platform called "Crusader" was to be used by dedicated data entry staff. It was decided in this task to limit the study to the data entry personnel or Crusader Operators (C.O.s), and to assess the impact they have on the Information Officer (I.O.) of the Control Room, who is the information transfer manager.

The Crusader Software package is a Windows® based interface for inputting traffic information supplied by the Swedish National Road Administration. The Crusader software uses pull down menus of incidents, accidents, road closures, delays and other traffic information which is matched to its location in the Twin Cities Metropolitan area and its duration. By selecting the proper traffic information, giving it a duration, and matching it to a location, an operator can assemble and send out messages. The Delco radio transmission system is no longer in operation and further study of its capabilities would not reflect the research to be conducted in the near future.

Through a quick study of the two Crusader Operators who enter data into Crusader, we found that they have likes, dislikes, and concerns about the Crusader software, the communication links in the Control Room and where they are stationed in the Control Room. The C.O.s were new to their jobs when this survey was conducted and we observed that they asked frequent questions having to do with the location and the direction of the incidents. We also determined that the C.O.s direct their questions mainly to the Information Officer on duty.

METHODS OF EVALUATION

A questionnaire was designed for the two C.O.s, and a separate one was designed for the I.O.s working in the Control Room to determine needs, like, dislikes, impressions, and suggestions. This was a subjective survey and the responses have been summarized in the following section to develop areas of future study. The completed questionnaires are included

in the Addendum. An example of each questionnaire is included at the end of this document. (See Appendix G. Crusader Operators and Information Officers Questionnaires).

Crusader Operator Questionnaire

A Crusader Operator questionnaire was created to find what problems (if any) the operators are having with the software. The operator's likes, dislikes, difficulties with the software, and with sending messages were examined. The location of the trilogy operator was also addressed. This questionnaire was divided into three sections: Software Ratings, Information Collection, and Position of Operator.

Software Rating

From the C.O.'s stand point the overall rating of the crusader software is fair to good. Both operators agreed that the software is simple to use, because of its pull down menus and point and click interface. However, they both felt that it should be more efficient and user friendly. Menus are very long and include large amounts of information that is not relevant. For instance the location menus list roadways (I-35, I-394) and road length destinations (Laredo, Texas to Minneapolis, or Dubuque, Iowa to Duluth). This is probably due to the conventions established for location coding across the United States. This is distracting when looking for the roadway that runs from the far northern quadrant of Minneapolis to Hudson, Wisconsin.. The C.O.s do not care if the roadway then runs south to Texas from that point. Another complaint is with the grouping / location of these messages and locations lists. Frequently used phrases are time consuming to find. There is no interface choices for moving the most frequent messages to the top of the list of choices. The messages that are used most often are in the middle or the end of long lists, thus taking more time to search and find.

When C.O.s were asked what their experiences were with the message lists, both operators agreed that there are not enough valid messages for the incidents that occur. For example, a car in a ditch or a flat tire are not on the lists. Operators must improvise messages to match what is actually occurring. The operators estimated that only 50-85 % of the time there was an exact message found to match the incident that was reported, and that only 60-80 % of the time they could find the exact location including cross streets that were involved. These percentages need to be higher for the system to have a positive impact on traffic and for the operators to feel that they are sending valid information.

There is no visual feedback to the C.O.s showing them the results of their message entry. After sending the message the Crusader screen clears and resets for further message entry. The operators do not get any form of visual feedback, for instance a display showing what is currently being received by the in-car receivers. This is very important for error correction

and to help the operators remember what has been sent. Currently they can look at a sent message list and a log of messages, but this does not give them the ability to note corrections that need to be made. For example, if an arrow pointing in the direction of traffic effected by an incident is backwards, there is no way for the C.O.s to know that there is a mistake. Further, if several messages are sent during peak hours, there might be a message that needs to be canceled but the C.O. does not remember the message. They would have to examine the long list of sent messages to see which ones need to be canceled. Whereas, if they had a feedback system or display of what driver's have received, they might notice an old message and cancel it quicker. This reduces the burden on the C.O.s to remember all messages, their durations, and locations.

Recommendations

- Adapt the software to make it more efficient. One way would be to have a memory system or preference file for messages sent. The number of times a message was used would be counted and the most frequent messages would be placed at the top of the list in descending order (most to least). If a preference list file is included where C.O.s could place their most commonly sent messages, they could access this file directly for common messages. This file could also have all scheduled maintenance and road construction schedules entered. This file could be updated during off peak times and could be the first thing opened by the C.O.s in the morning. This would save the operators time when looking for messages. This would also make the software more user friendly.
- Use an interface that integrates an electronic map when choosing the location and direction of the incident. A map could be on the screen instead of a long location list that the operators have to search to find the correct location.
- Allow the C.O.s feedback by developing a software function that shows an example of the actual, real-time end-user display. This could be quick fixed by mounting an actual in-car display device next to the data entry person so they can observe what their operation of Crusader is actually producing. This will not only alleviate the problems discussed above but would improve the C.O.s satisfaction with their work.

Information Collection

C.O.s were asked to relate how they collect and assemble the messages that they broadcast to in-car devices. They stated that they were able to determine easily what type of incident had occurred by watching the roadway cameras, and listening to the North and South station operators and I.O.s. However, C.O.s further related that they had difficulty in learning

and remembering the Metro area freeways and interchanges, and had to ask frequent questions (usually to the I.O.) of the exact location of the incident. The location of the incident was asked more frequently when the "exact" location reported could not be found on the message list and thus had to be estimated. This is clearly a function of being a novice to all of the roadways present in the Metro area. We assumed that as C.O.s became more and more familiar with the Metro area that location questions would decrease.

Both C.O.s reported asking the I.O. for help when they were unsure about any aspect of an incident. The number of times that help was requested ranged from 2 -10 times per peak shift period. Again this points out that C.O.s feel that I.O.s are the person that can best answer all of their questions.

Recommendations

- Reduce questions by the C.O.s by increasing their familiarity with the Metro area. This could be accomplished in two ways; (i). Increase the training of the C.O.s, either have them be trained as North / South station operators first and then move on to Crusader Operation, or increase their pre-training before actually becoming C.O.s. (ii). Hire full time permanent C.O.s. A permanent trained employee would become an expert operator in time and would not need to ask as many questions.
- Increase comparison measures for data collection by using a software operator that is extremely knowledgeable about the metro freeway system .
- Provide a feedback system that would verify the transmission of correct messages.
- In the future an unified input system used by the North / South operators and/or the I.O.s which could send messages to changeable message signs, ramp meters, and in-car devices would provide better consistency in data entry. We realize that this would be very difficult for the current I.O.'s who have a very time-consuming job and do not need the extra burden of entering data.
- Finally, use a communication system (microphones at the I.O. to headsets for the C.O.s) where the C.O.s would be able to hear what the I.O.s are repeating to the public service and Mn/DOT employees at their station. It becomes hectic and loud in the Control Room during rush hour incidents and if the C.O.s could hear what the I.O.s are all ready repeating several times, they might not need to ask as many questions.

Position of Operator

The Crusader Operators were also asked about their location in the TMC Control Room. Both agreed that they like to be next to the I.O. because then they can hear and communicate more clearly with them. This allows them to verify incidents quickly. Their present position

allows the crusader operator to see most of the monitors and other operators, but some monitors are obscured by the station operators and the lowest level of the monitors in front of them.

Recommendations

- Keep the present position of the C.O.s near to the I.O. This is a good place for the C.O.s given the present layout of the Control Room.
- To increase visibility of the monitors in the Control Room, the C.O.s should be placed closer or between the North / South station operators. If they are placed in-between the two station operators they can observe both areas of the Metro and have an increased view of all of the monitors. This would also increase co-operation between the operators and the North / South stations. This is only practical if the Control Room is redesigned or remodeled. Careful task analysis of the Control Room should be conducted to increase information flow within the room and to aid all operators in observing the monitors. A tradeoff analysis between the needs of the Crusader Operator and their position within the Control Room needs to be completed weighing the advantages and disadvantages to their positioning.

CONCLUSION

The crusader software is relatively simple to use from the stand point of clicking on windows, getting the messages, and sending the messages. Most problems with the software are within the message assembly steps. The other main problem is familiarity with the Metro freeway system and personnel changes. A dedicated operator that knows the Metro area is needed to operate the software efficiently. Knowing the characteristics of traffic during peak periods, would also help when estimating the duration of incidents. This interface is designed for easy menu selection but needs refinements to its message lists and feedback capabilities.

Information Officer Questionnaire

A questionnaire was given to two information officers, to get their feedback on the Crusader Operators. Questions were asked as to I.O.'s amount of time in helping C.O.s, and to the process of being asked questions as an increase in their workload.

Information Officers Time

The Crusader Operators noted that they are frequently questioning the I.O. In response to this, the two I.O.s surveyed stated that these questions do not affect their ability to do their job effectively. However, the I.O.s did feel that during peak activity periods they are too busy to

answer all of their questions as they are already repeating the information three to four times to other sources..

We asked the I.O.s how often they felt that the C.O.s asked them questions. They reported that it varies from day to day. However, a question was generally asked to them about every major incident. The types of questions that they were asked, appeared to follow the information sequence that was needed for input into the Crusader Software. They are often asked where the incident were located, the direction, cross streets, if the incident was an accident or a stall, and how long the delay would last. This implies that the I.O.s feel that the C.O.s are asking them questions about what to input into the software.

We asked if the I.O.s were ever annoyed by being asked questions so frequently by the C.O.s They reported no general annoyance or reluctance to help the C.O.s, but felt that they were too busy at times to answer all questions. They emphasized that during peak activity times, the system should be able to run independently without their help. They stated that this peak time is when information transfer needs fast action, done correctly. This can not always be done when the I.O.s are queried by the C.O.s, and I.O.s felt that this could lead to a confusion with the C.O.s when messages were assembled.

Questions by the Crusader Operators

We asked the I.O.s to consider themselves a resource for questions and answers to the C.O.s and what would they do to improve that process. The I.O.s both cited the lack of efficient communication and comprehension making it difficult for the C.O.s and I.O.s to communicate. The I.O.s felt that a lack of understanding of the Metro freeway system raised unnecessary questions by the C.O.s.

Recommendations

- As before, to reduce the questions that are asked, the C.O.s should be very familiar with the freeway system. The C.O. should be able to pin point the location without asking questions.
- Dedicated training should be continuing with the emphasis on relieving the amount of time I.O.s spend helping the Crusader Operators. With time the operators will become familiar with traffic patterns and the Metro area, but currently they are placing an unnecessary burden on the I.O.s.

CONCLUSIONS

Information Officers have a demanding area of responsibility within the Control Room. The I.O. also has the most responsibility during peak periods and with information transfer. The I.O.s would benefit from having a dedicated well trained or knowledgeable Crusader data entry person who did not need to use them as a resource for information. Finally, communication capabilities could be improved in the control room to allow the C.O.s to hear the information that the I.O.s are repeating to eliminate some questions.

CHAPTER 6
TASK FIVE:
SHIFT WORK AT THE TMC CONTROL ROOM.

INTRODUCTION

Task Five consisted of a graduate student from the HFRL working one shift per week at the TMC Control Room. The student was trained and served one peak shift per week as a North or South station operator. As a further part of this work the student also completed any requests for studies, surveys, or general ergonomic and human factors analysis. This is a summary of the work that was completed from December 1992 to December 1993 . It was based primarily on observations and discussions that were done while working as an operator. Five topic areas of discussion are summarized below. This task follows these five areas of focus; (i). Control room operation, architecture, and human factors analysis. (ii). Message assembly and content evaluation. (iii). Potential users of software and job impact. (iv). Message evaluation methods. (v). Workstation design within the control room. The nine separate reports prepared for this task are included in the Addendum to this document. The reports are referenced within each of the five topics. Finally, areas of concern brought forth by the task reports are examined individually. These include information flow, human factors evaluation of messages, the Crusader software package, information systems, and workstation design.

The first topic introduced the reader to what actually takes place in the control room at the Traffic Management Center. (See Addendum, paper #1). It names the different areas in the control room and addresses specific problems related to the radio traffic announcer, information officer, and the North / South station operators. The possibilities of what human factors could do to improve the addition of new technology into the control room and the changing responsibilities within the traffic control room were also provided.

The next four topics related to the introduction of the Delco and the Crusader software systems into the control room. The first was an evaluation of the types of messages that are sent from the TMC to the driver. (See Addendum, paper #2). To evaluate this an assessment on the content of the messages that could be sent from TMC to the driver was observed and studied. Unfortunately, complete evaluation for the Delco was completed prior to complete evaluation of the messages. This study illustrated the worth of completing very simple paper and pencil evaluations before implementing the databases of messages. Results from this study showed that the messages that had been selected for the Delco radio could provide only very limited information to the driver. The RDS radio messages must be trusted by the driving public if it is to be used effectively by them. The messages must also provide

an accurate representation of what happens in the real world. The users that need to be considered in the RDS system were also discussed. These are; (i). the message sender and (ii). the driver or end-user.

Potential users of the Crusader software was the second topic. (See Addendum, paper #3). Three types of users must be considered; primary users, secondary users, and tertiary users. A advantage/disadvantage tradeoff analysis was done to show how the potential users of the Crusader software system could be impacted. This analysis looked at specific areas that a technical system could impact on a user. Also, a questionnaire was given to the Crusader Operators and provided results similar to the cost-benefit analysis. The position of the Crusader interface was found to be the lowest priority for the users who added the task of data entry through Crusader into their daily routine. These users felt that the system was not easy to use. An assessment of the Crusader software system, after the implementation of the system, also showed this result. (see Appendix , paper #4). Although the users replied that they understood how to use the Crusader software they were not able to complete the detailed questions about the operation of the system. This would support that a dedicated operator, where the Crusader data entry would be the only task for the operator, should be assigned during peak traffic periods.

The third topic was aimed at discussing a method for evaluating the message content that is sent to the driving public. (See Addendum , paper #6). This area of inquiry tried to establish what information is essential for a in-car traffic messaging system. The types of information the driving public uses when planning trips should be looked at, as a gauge to help determine if current message lists are adequately conveying the correct information. The evaluation of message lists must also address whether detailed descriptions are needed for better interpretation or if they are just redundant. This topic merely discussed the different aspects of message lists that need to be looked at and how drivers develop their traveling plan. The user centered system architecture topic looks at the different needs for the driving public and the sender of the messages when implementing new technologies. (See Addendum, paper #7). The ideal data base for software would allow the Crusader Operator to send a message in the format that they are familiar with and then the driver would receive it in the format best suited for them. This would cause less confusion and more accurate information being sent and received.

Consideration in the implementation of prototype systems in the traffic control room was the fourth topic within this task. (See Addendum , paper #8). It is an abbreviated version of a sociotechnical study. The implementation of the Crusader operating station and software was used to show what needs to be done before implementation. It also addresses how changes are initiated and the need for pro-active questioning and assessment. These

questions were related to matching the social system, (the people using the component) with the technical system (the technology, “Crusader”, and the environment).

Finally, the fifth topic addressed the workstation design in the traffic control room. (See Addendum , paper #9). This focused on the South operator work station and the traffic announcer workplace. The evaluation was done based on ergonomics principles discussed in Task One and demonstrated how human factors needs to be addressed before designing a workplace. Results indicated that for both of these work areas it was found that the sight angles are inadequate. The current viewing angle for both workers results in the upper monitor being missed and the lower monitors being obscured. Lighting and climate issues also need to be considered when designing a workstation.

This work was done to provide the reader with the insight as to how human factors can contribute to the design of the control room, organization of the workplace, and the design and implementation of the technology. Human factors alone can not do any of these but human factors can provide the support for a more successful outcome.

Information Flow

The current information flow of the traffic control room, along with the implementation of new technology and a new information flow, which brings a new purpose within the control room, are discussed here.

As new technology is incorporated into the control room, the control rooms working structure will change from one with a basic traffic control stations, to one that is more of an information servicing system. With this change more consideration should be given to the sociotechnical system that will support the system. Many factors can interact and make sociotechnical systems difficult to deal with. Some problems within the traffic control room, which make up some of these factors are related to the personnel within each area. The I.O.s work load varies depending on what traffic is doing. The I.O. can be extremely busy at any given moment. Therefore, it would be unsuitable to fit more information technology upon them. The North/South station operators workload is compared to the I.O. and does not show a difference in the amount of time or workload. However, the limited number of operators (two) does cause a problem, because the variability between the actions of each operator is very high, and thus not consistent.

Recommendations

- Combine the tasks of the station operators within each station or to the tasks of the C.O. This could be done with a common interface that controls both the station operators and the C.O. tasks. This would improve consistency within the control

- room and ultimately traffic control.
- Use Human Factors to assist in interface design on prototypes from both the workers and the drivers point of view.
- Use Human Factors to consider job structure and suggest possible designs for the future.
- Provide current job manuals and retraining procedures for station operators.
- Create a time line for prototypes and final products for interfaces.
- Create a universal interface which can control several tasks with one data entry.

Human Factors Evaluation of Messages

When new devices are introduced to the public for intended use, the devices must be easy to understand and use. If this does not happen the device will not be accepted. With the Delco radio, messages are sent to the user regarding traffic conditions, via a sender at the TMC. The driver, as well as, the sender must both be considered “users” of the system. The messages that are sent must not only provide accurate information that represents the real world but must be consistent with other medians of traffic information, (radio, t.v., etc..).

Results

An evaluation between the traffic radio announcer (TRA) traffic messages that were broadcast and the RDS (Delco) traffic messages sent was completed. Results show that twenty-six out of forty-eight times there was complete confidence in the match between the RDS message chosen for the incident and the information broadcast during traffic announcements (See Addendum, paper #2 for results).

Recommendations

- Make sure that RDS messages match TRA broadcasted messages.
- Design of the software interfaces should consider who will operate it and, where possible, combine the entry messages tasks together.

Crusader Software System

As new technology is introduced into a system, social requirements are occasionally neglected. The impact of the Crusader system on the staff in the control room at the TMC is examined here.

Three types of users must be considered as users of the Crusader software. These are: (i). The primary user, which include North/South operators, I.O.s, and the final dedicated person to operate Crusader (C.O.s). (ii). The secondary users, recipients of information from

I.O.s and weather reports, including; Mn/DOT personnel, Police and Emergency vehicles, Road maintenance and Highway Helpers. (iii). Finally, the tertiary user, the general public.

Results

A tradeoff analysis was done to consider how the Crusader system would impact the users in a number of areas. This analysis showed that the Crusader system had a higher cost for all control room users, except for a dedicated user of the Crusader system. When the Crusader software was implemented into the control room, both the operator and the information officer operated the system for approximately two weeks each. After this time an implementation evaluation questionnaire was completed. All of the users of the system completed a questionnaire that asked for opinions on the ease of the system. This included how well the task of sending messages fit in with their regular job, their perceived order on priority of tasks, and general comments on improvements to the system. This assessment showed that the users felt their job was hindered when the task of Crusader operation was added to their jobs. For all the results of the questionnaire See Addendum, paper #5.

Recommendations

- Have a dedicated user for the Crusader system.
- When implementing new technologies use a cost-benefit analysis to assess who the “best” user within the system will be.
- Look at interfaces currently being used and try to incorporate good factors from these interfaces into new ones.
- Use questionnaires to assess new technologies and to compare outcomes.

Information Systems

Traffic messages sent from the TMC on RDS systems need to be understood by the driver to be effective. Also, messages must be useful to the drivers. To find out what messages will be useful to drivers, a message evaluation can be done. To determine what the best message will be, five aspects should be examined. These are: (i). How drivers plan their journey. (ii). The advice drivers currently use when planning a journey. (iii). How drivers calculate inconvenience. (iv). How drivers rate confidence with traffic messages. and (v). How drivers rate the current messages already developed.

Not only does the driver need to be able to interpret messages that will be useful, but the sender of the message needs to understand the system. The ideal database would allow the sender of the messages to use the familiar format for them and the end-user (driver) would then receive the message in the format they could best interpret and use. This is important so that the “human” component will be used alongside this technology. We will

then have a technology that people want to use.

Sociotechnical issues must be addressed when implementing new technologies so that people will use the systems. The questions raised here might be: What does the prototype system intend to achieve and how does it intend to achieve it? How does the implementation of the prototype integrate with the current workload of the employees? Do employees affected by the implementation of the prototype have the correct skills to deal with the changes it brings to the existing system? Will there be time for feedback and evaluation from employees affected by the system? How does the prototype fit in with other research projects? At first the user of the system may not appear important compared to the new technology but humans must be considered part of the whole system and addressed accordingly.

Recommendations

- Evaluate message lists used in RDS to make sure they will be relevant information for the drivers.
- Consider the types of information drivers use for planning trips when developing message lists.
- Address the human aspect when incorporating new technology into a system.

Workstation Design

The workstation of any system is a vital part of the system and should be designed accordingly. Ergonomics must be incorporated into the design. The South operator station and the traffic radio announcers workstations were examined as part of this sub-task. Unfortunately, this was a limited study and could not incorporate all the problems present with the current workstation layout. The purpose here is to demonstrate a few factors that need considering when designing and developing new workstations.

Recommendations

- Reduce the number of monitors that the operators must observe.
- Consider, as more technology is introduced, that the operators may become the monitors of the system rather than the traffic, and thus the skills for such operators may be different from the skills that are presently required.
- Environmental aspects (lighting, climate, noise) need to be examined.
- When making changes to the control room, plan for the expected increase in noise and movement in the control room. Without proper examination, a bottle neck of movement or information transfer can develop.

REFERENCES

- Chapanis, A. (1959). Research Techniques in Human Engineering. Baltimore, MD. : John Hopkins Press.
- Department of Defense, (1981). Military Handbook: Human Factors Engineering Design for Army Material, Mil-Hdbk-759A .
- Department of Defense, (1989). Military Standard: Human Factors Design Criteria for Military Systems, Equipment, and Facilities, Mil-Std-1472D.
- Glass, G. V. & Hopkins, K. D. (1984). Statistical Methods in Education and Psychology. Englewoods Cliffs, N.J. : Prentice-Hall, Inc.
- Hancock, P.A., Wulf, G., Thom. D., & Fassnacht, P. (1990). Driver workload during differing driving maneuvers. Accident Analysis and Prevention, 22, 281-290.
- Konz, S. A., (1990). Work Design: Industrial Ergonomics. (3rd Ed.), Scottsdale, AZ. : Publishing Horizons.
- McCormick, E.J. and Sanders, M.S., (1982). Human Factors in Engineering and Design. New York, NY. : McGraw-Hill.
- Shneiderman, B. (1986). Designing the User Interface: Strategies for Human-Computer Interaction. Reading, Boston, Mass. : Addison-Wesley Publishing Company.
- U. S. Nuclear Regulatory Commission, (1981). Guidelines for Control Room Design Reviews. Washington. D. C. : Division of Human Factors Safety.
- Woodson, W.E., and Conover, D.W., (1964). 2nd Ed. Human Engineering Guide For Equipment Designers. Los Angeles, CA. : University of California Press.
- Woodson, W.E., Tillman, B. and Tillman, P., (1992). Human Factors Design Handbook. New York, NY. : McGraw-Hill, Inc.

APPENDIXES

APPENDIX A : Linkage Diagrams.

LINKAGE DIAGRAMS:

The linkage diagrams that follow provide a way to view the progression of movement to complete certain tasks. The lines are drawn from the viewing field (the road or highway), to the buttons that would be pressed in sequence to complete the various tasks. The user would glance down at the radio and to the viewing screen and back to the driving field of vision as the steps progressed, therefore, we see triangular or straight line movement from the viewing field, to the steps in the task, and back to the viewing field. These are used to help determine the amount of time the driver is distracted from the primary task of driving. We can time the drivers in simulation as to the average amount of time the RDS system distracts the user from the primary task. This can be done both statically and during dynamic driving simulations. We also use these diagrams to determine steps to be used in designing tests.

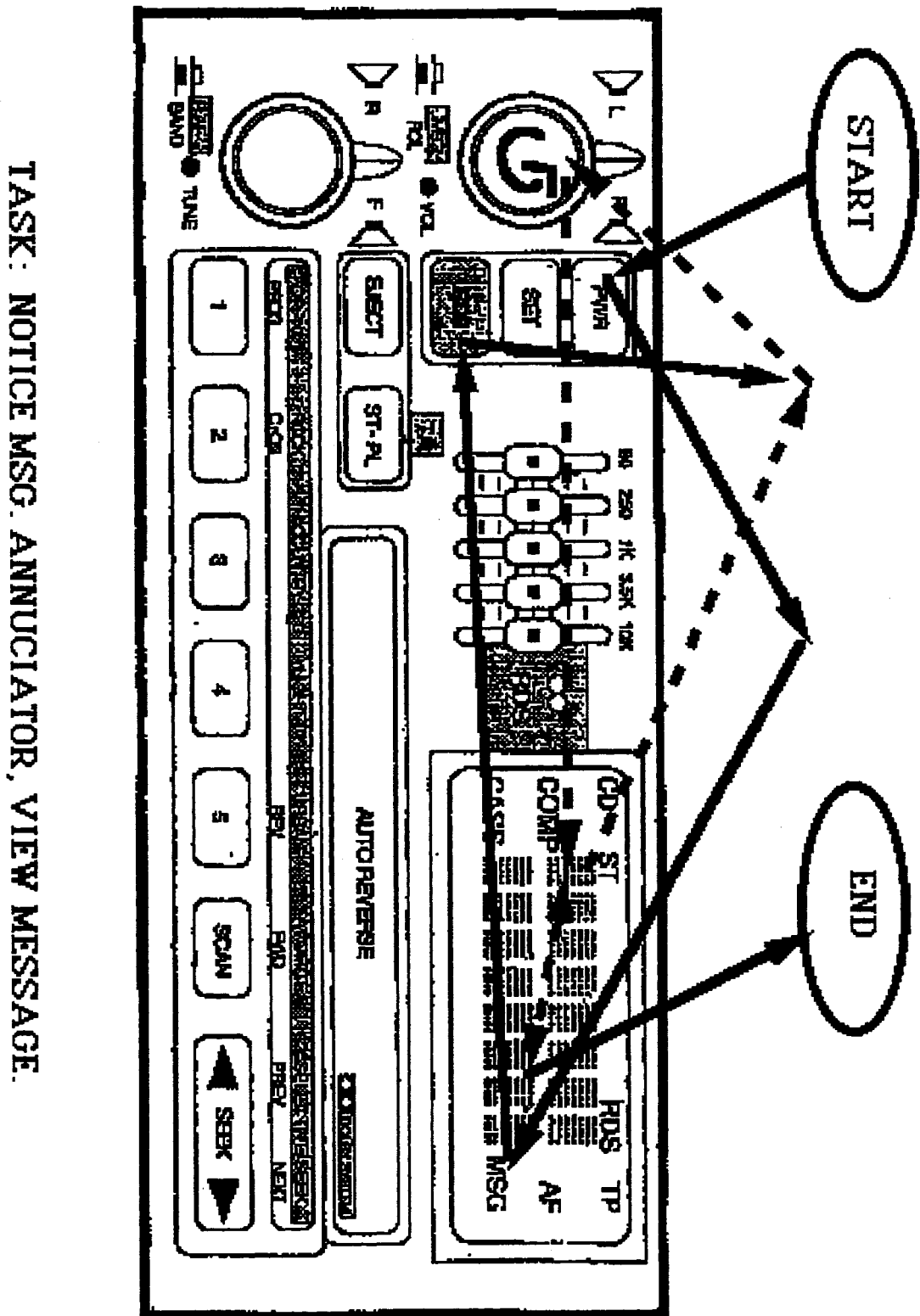

TASK: TURN ON RADIO, TURN ON RDS, START T.A. FUNCTION

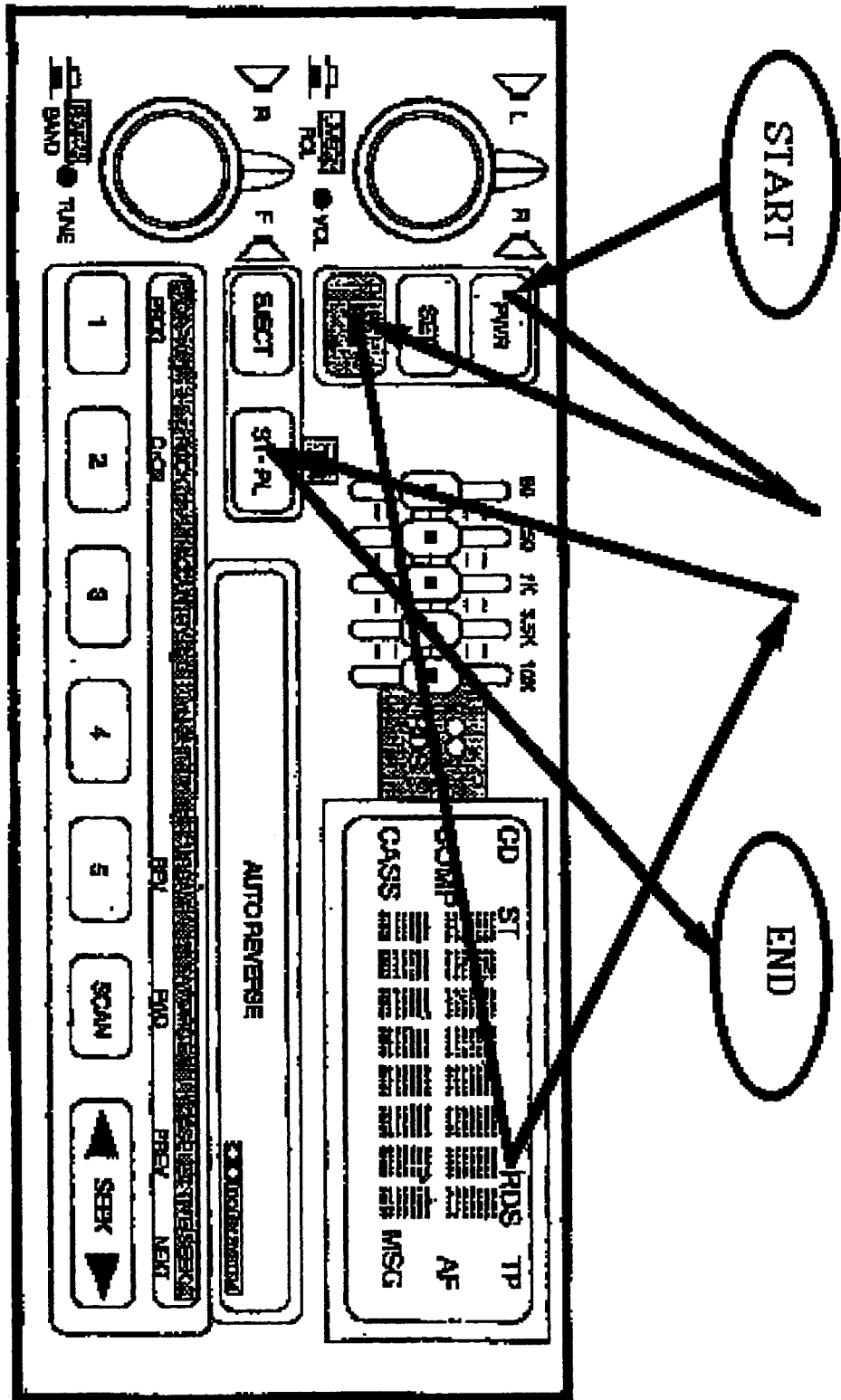

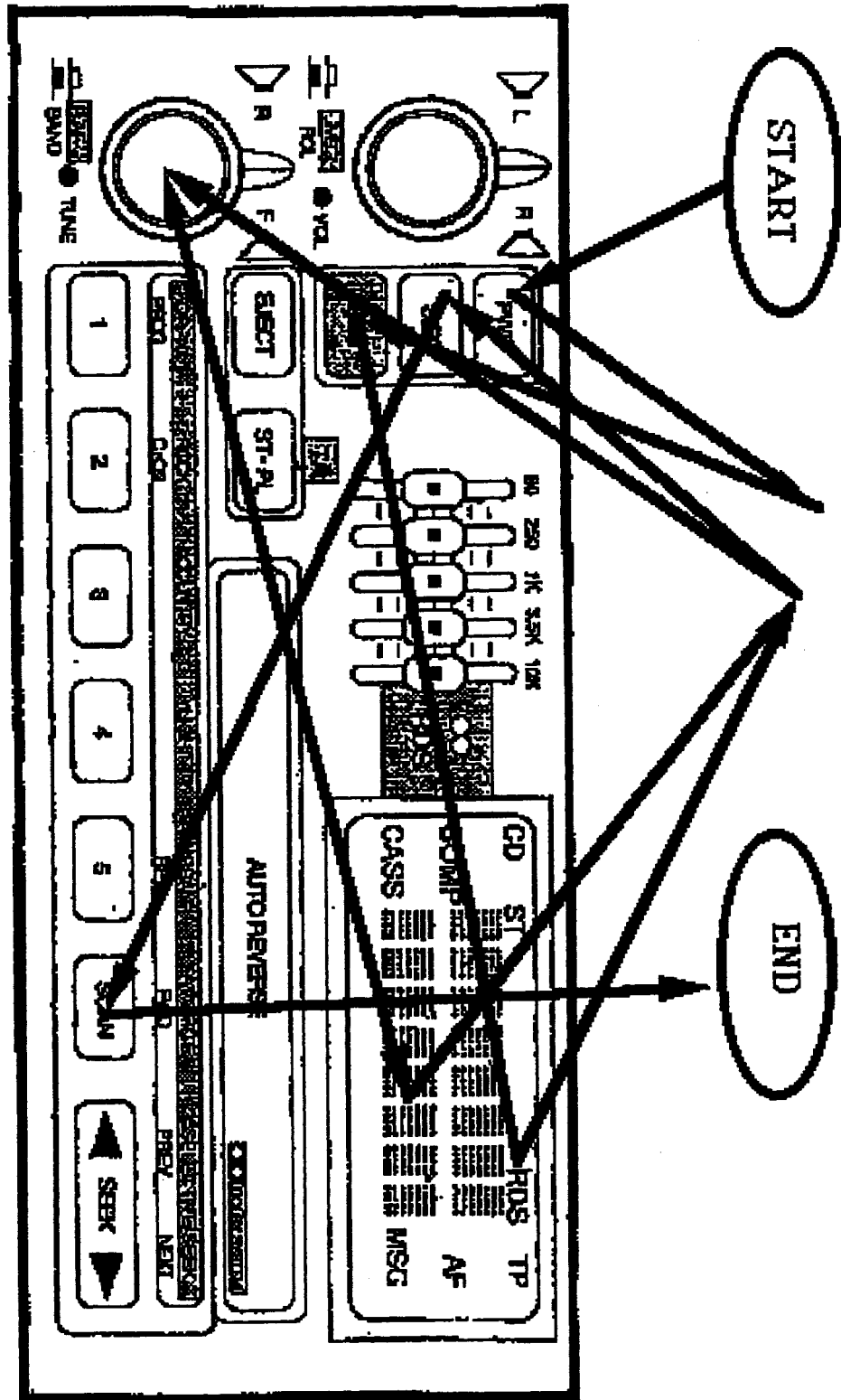

**TASK: SCAN ROCK FORMAT FOR STATION
WITH PERIODIC TRAFFIC ANNOUNCEMENTS**

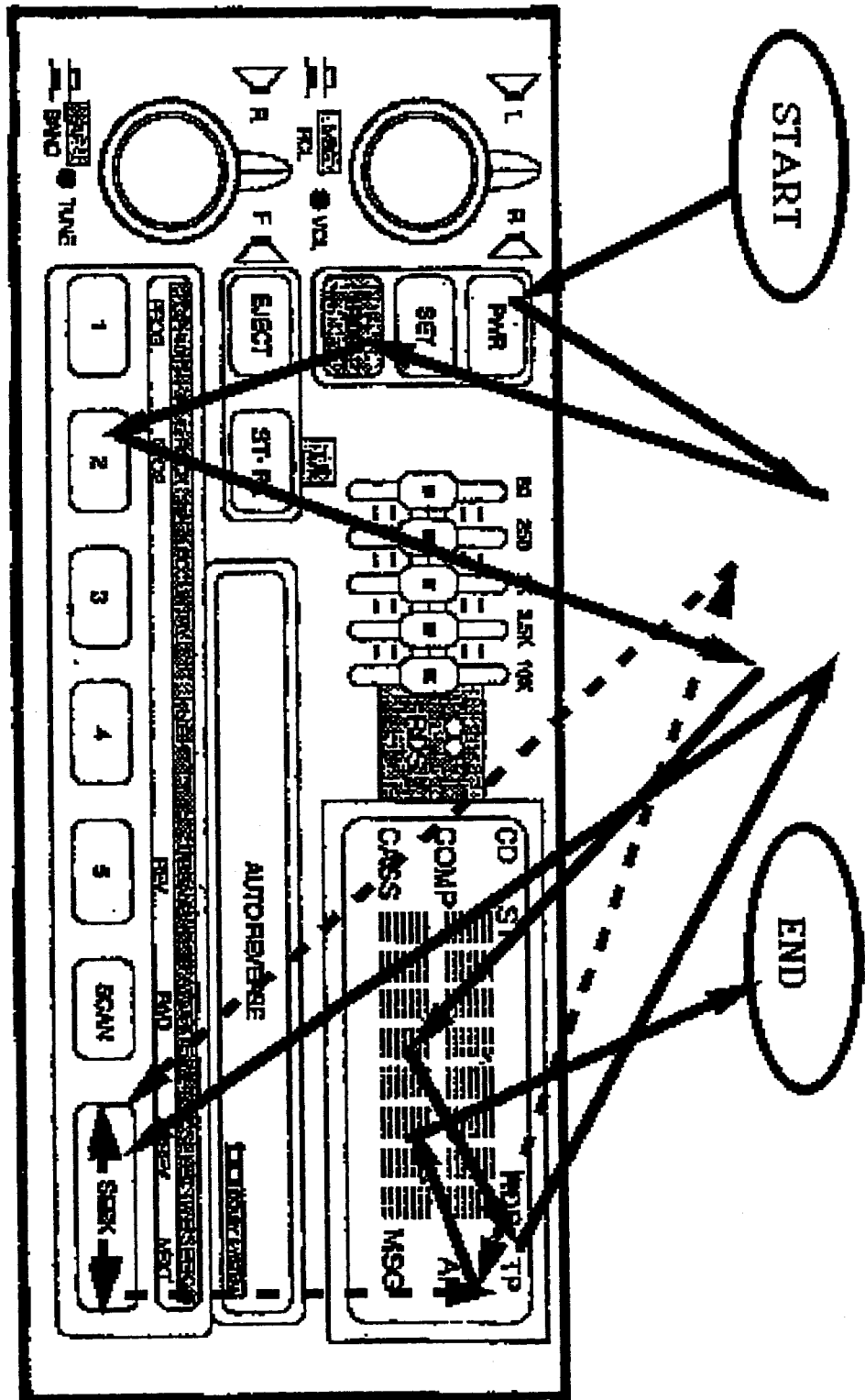

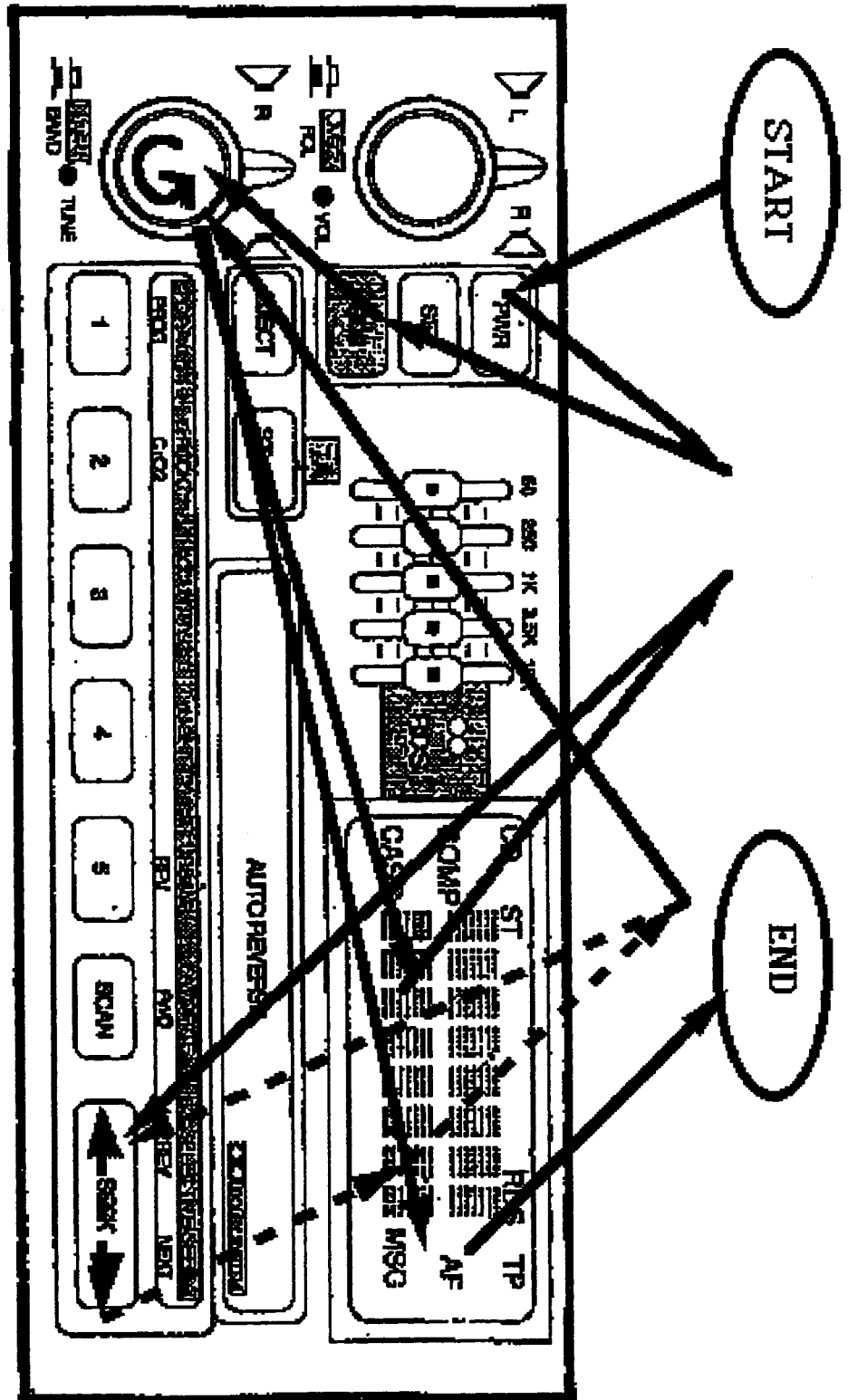

TASK: FIND N.P.R. FORMAT, SCAN FOR PROGRAM,
TURN ON ALTERNATIVE FREQUENCY.

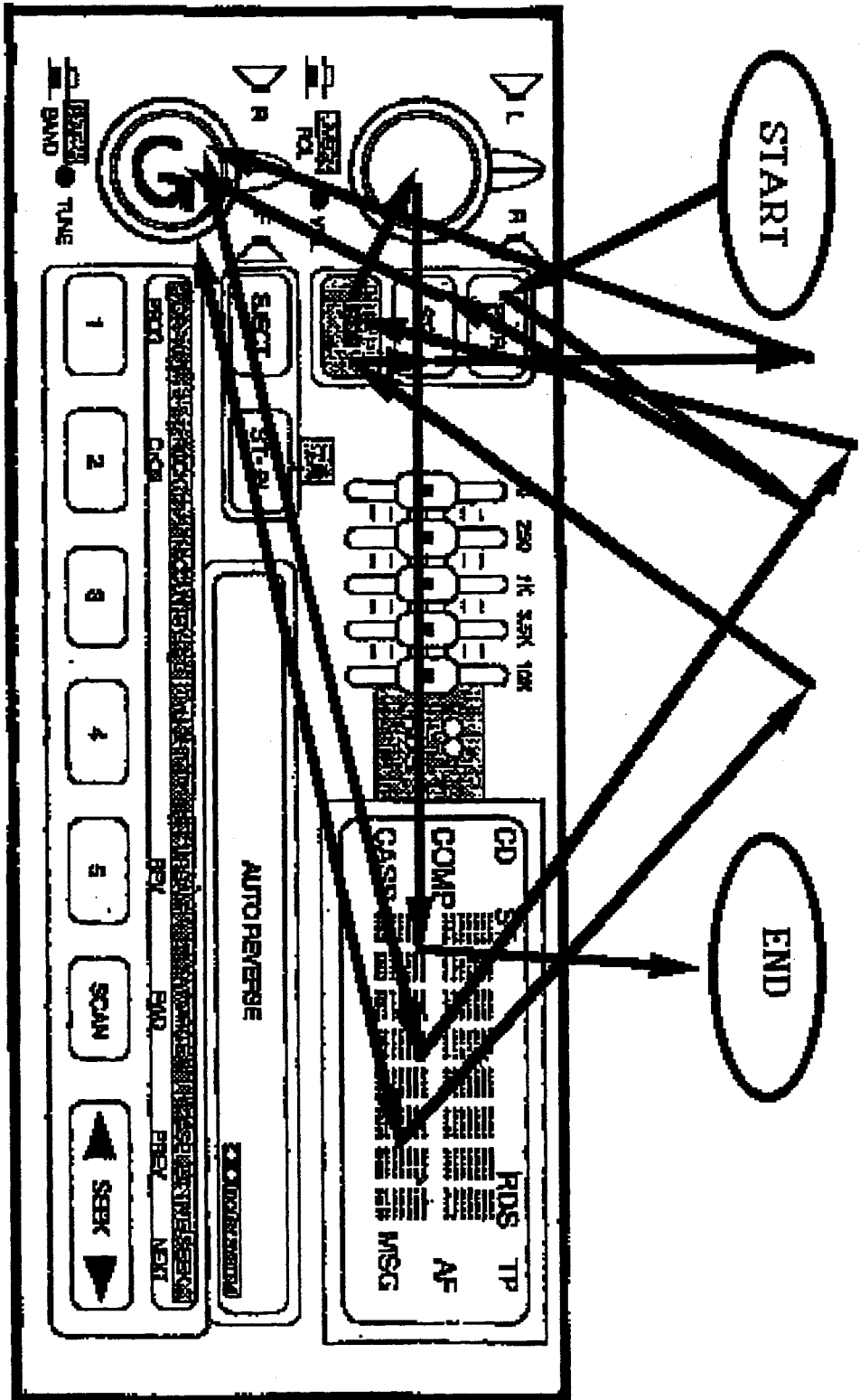

TASK: CHANGE CLOCK TIME & USE AUTOMATIC RDS CLOCK UPDATE

APPENDIX B : Flow Diagrams.

FLOW DIAGRAMS:

The flow diagrams that follow provide a way to view the progression of movement to complete certain tasks. These show the progression of decisions and steps that the users must perform in sequence (including the buttons that would be pressed) to complete the various tasks. We use these diagrams to determine the steps to be used in designing tests. We establish the steps a user must complete to correctly complete a task and then test the user under static and dynamic conditions on the correct sequencing. We will train the test subjects and test ease of operations and learning of the steps of the tasks.

A circle surrounding a #1 indicates where there is a five second default limit for making decisions. This is included on flow charts where the decisions by the driver is very complex and they might take longer than five seconds.

GOAL: Turn On R.D.S., View Message

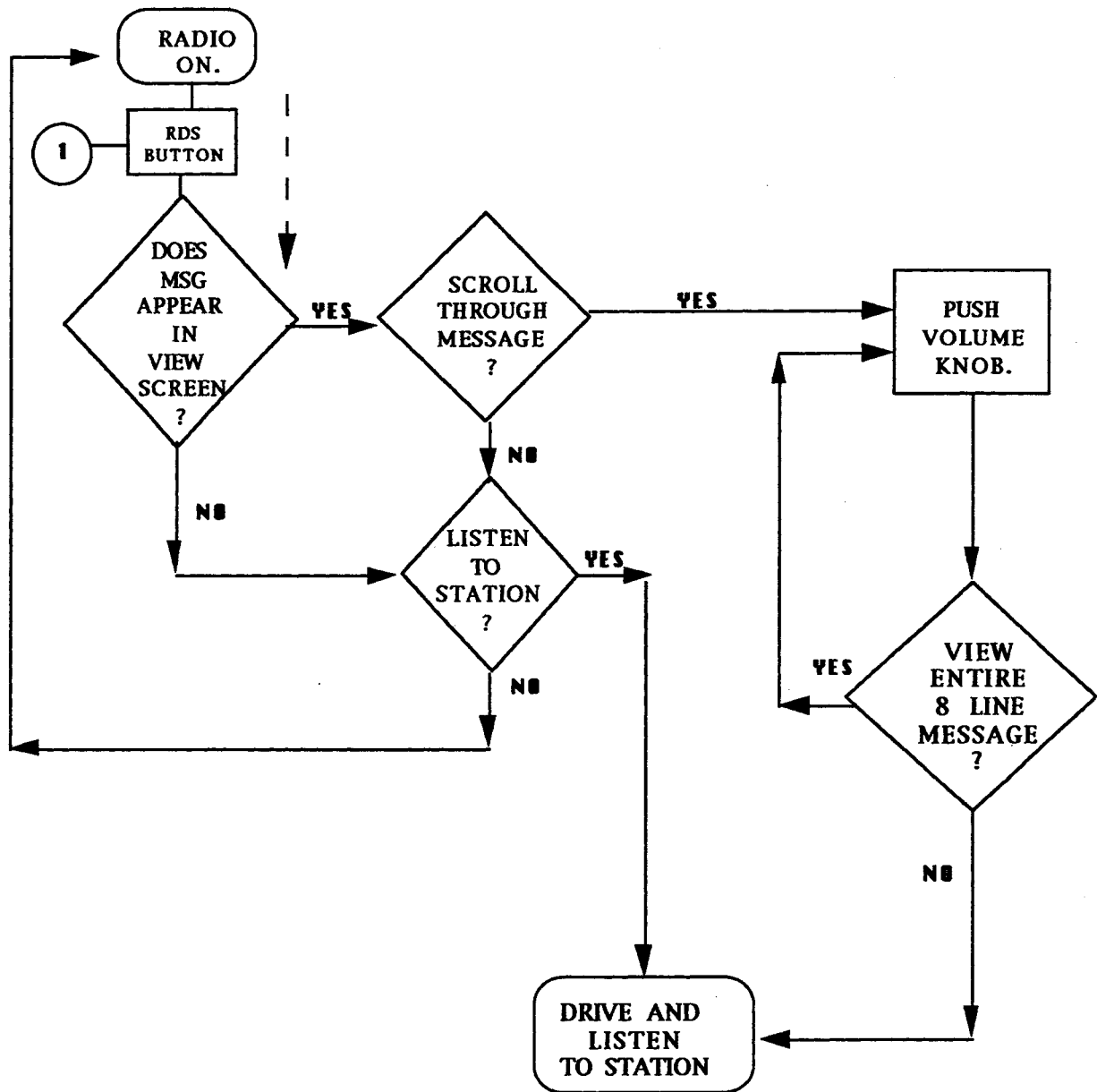

GOAL: Listen To Traffic Announcements Using T.A. Button / Function

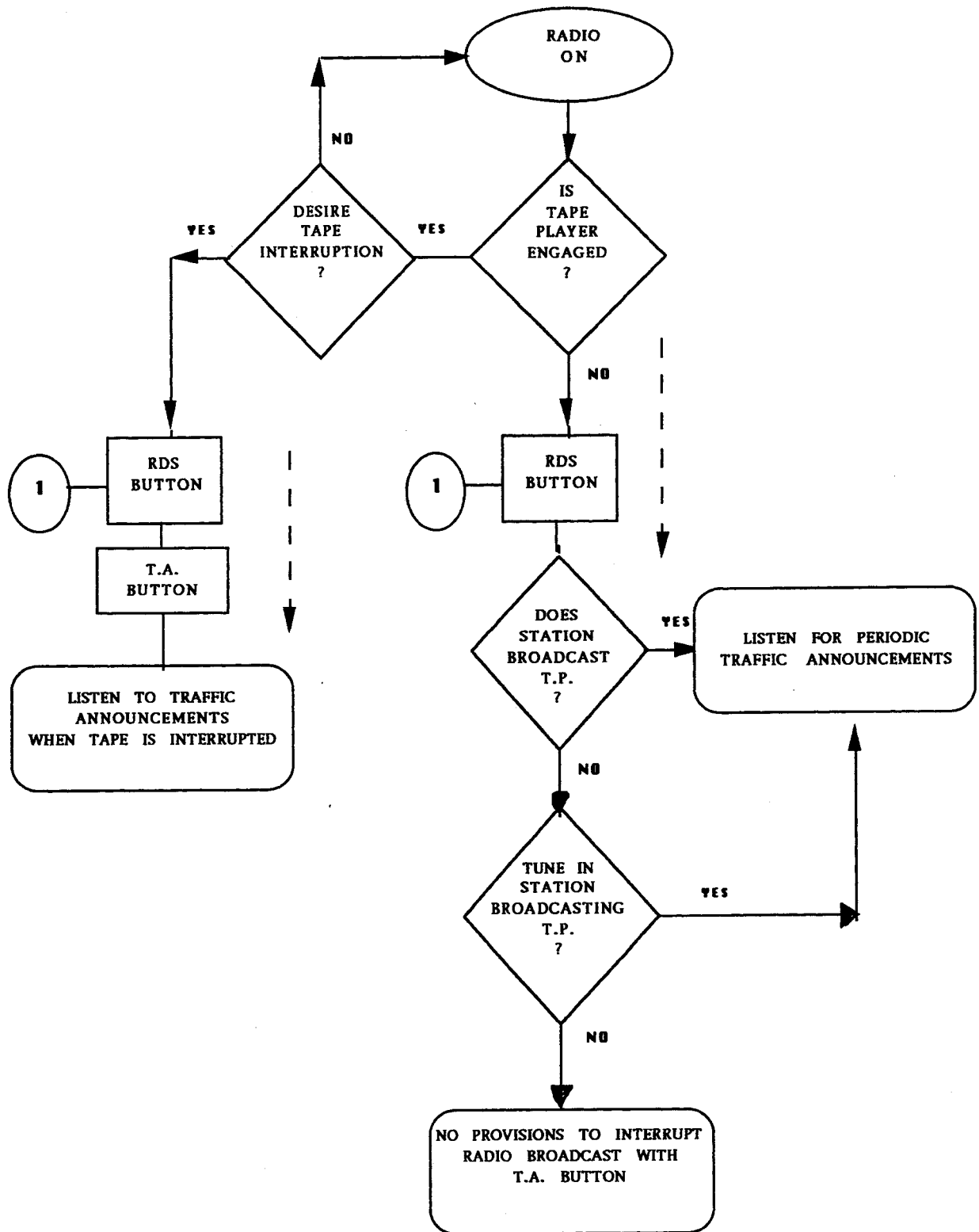

GOAL: Set Favorite Format

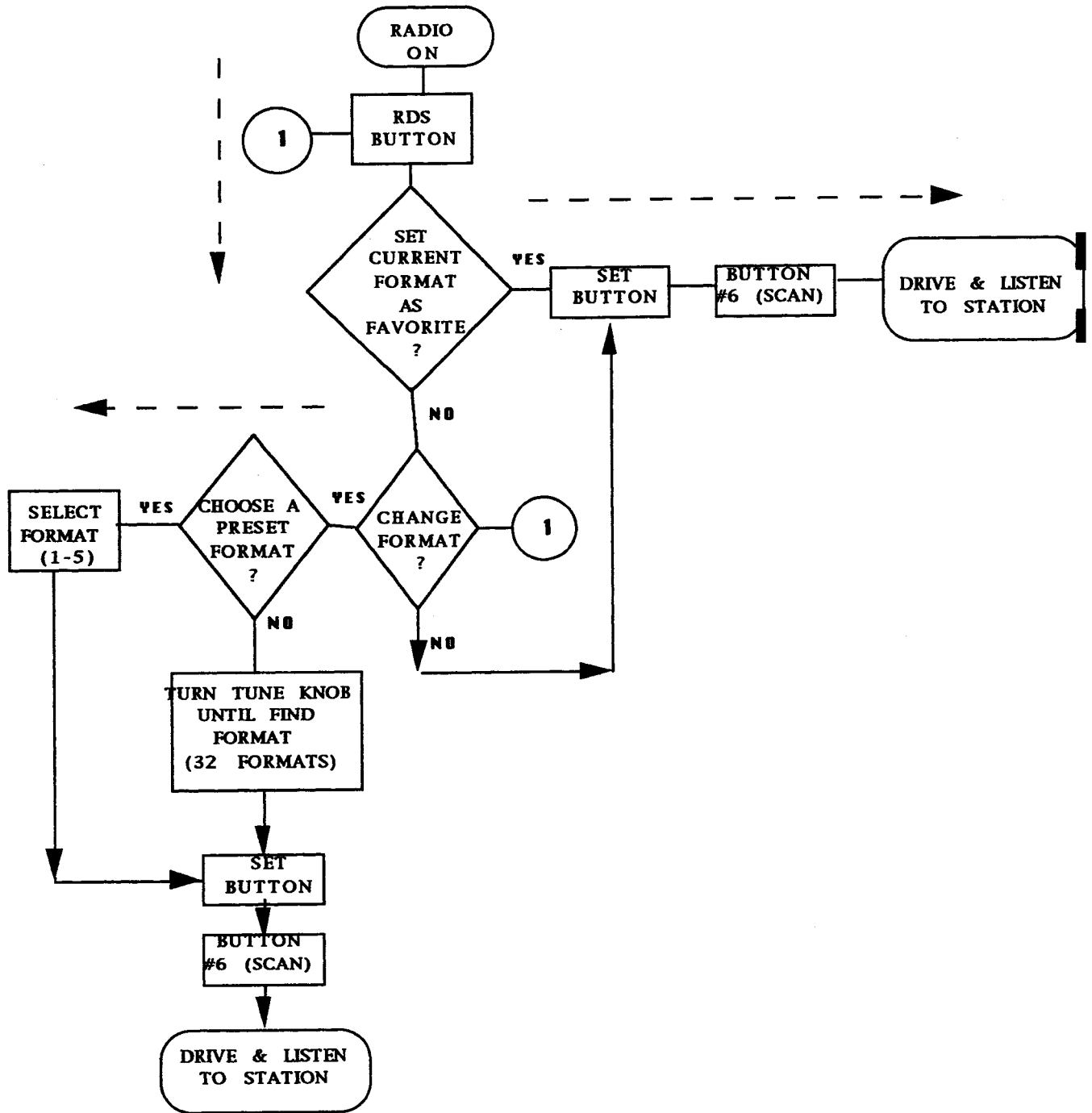

GOAL: Stop listening to tape player and scan R.D.S. format rock station

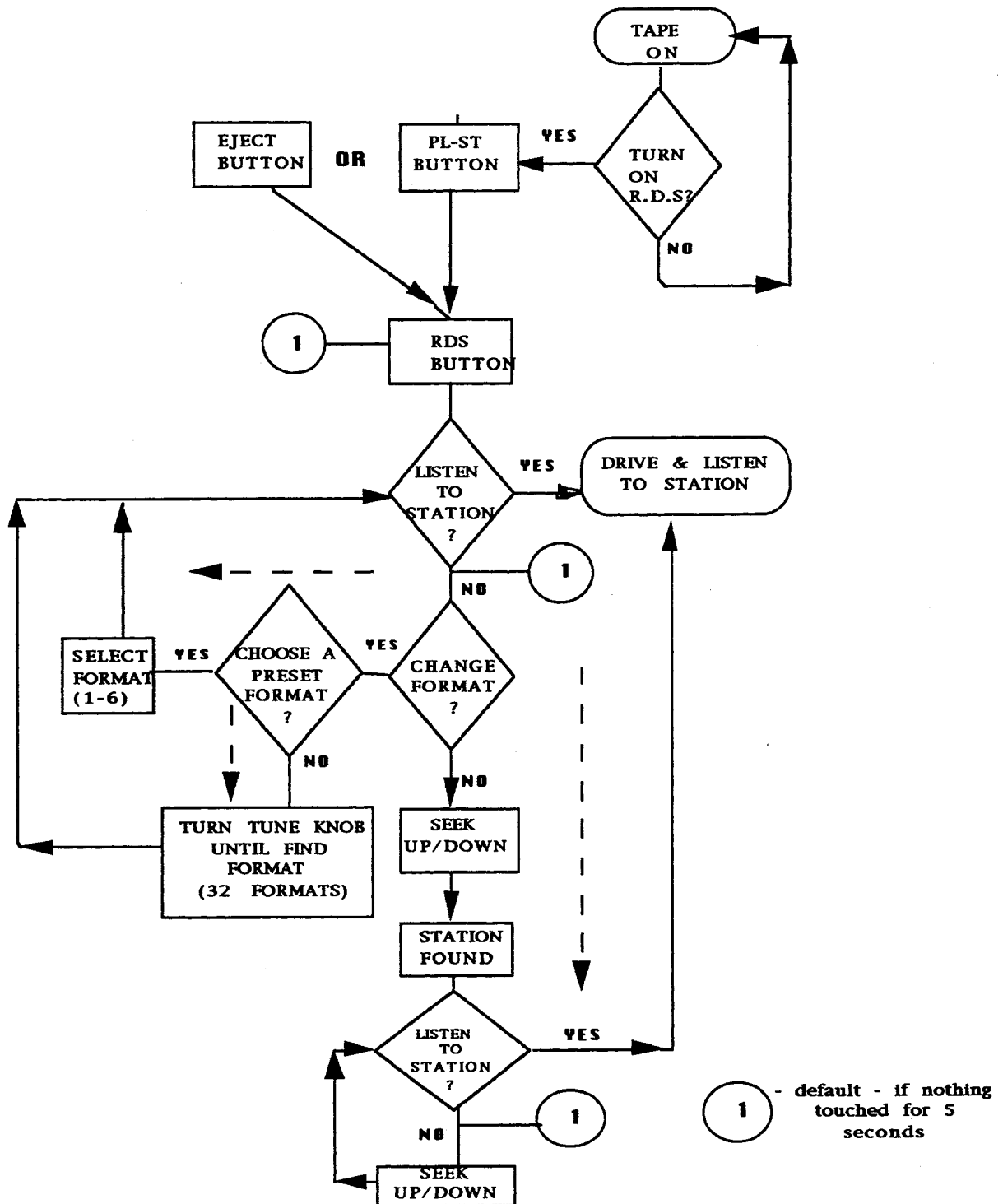

GOAL: Turn On R.D.S., Find N.P.R. Station, & Activate A.F.

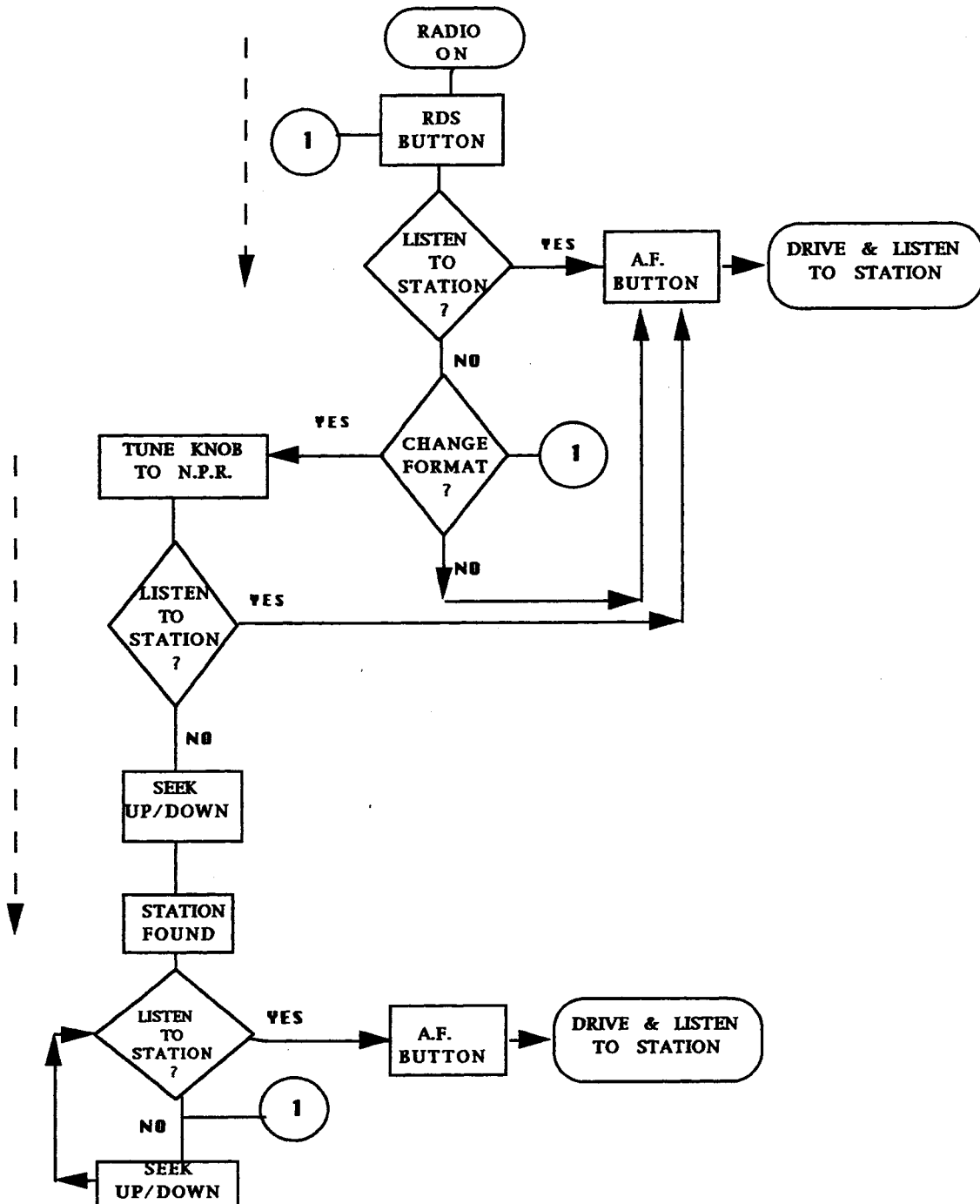

GOAL: Set clock & use automated clock time functions.

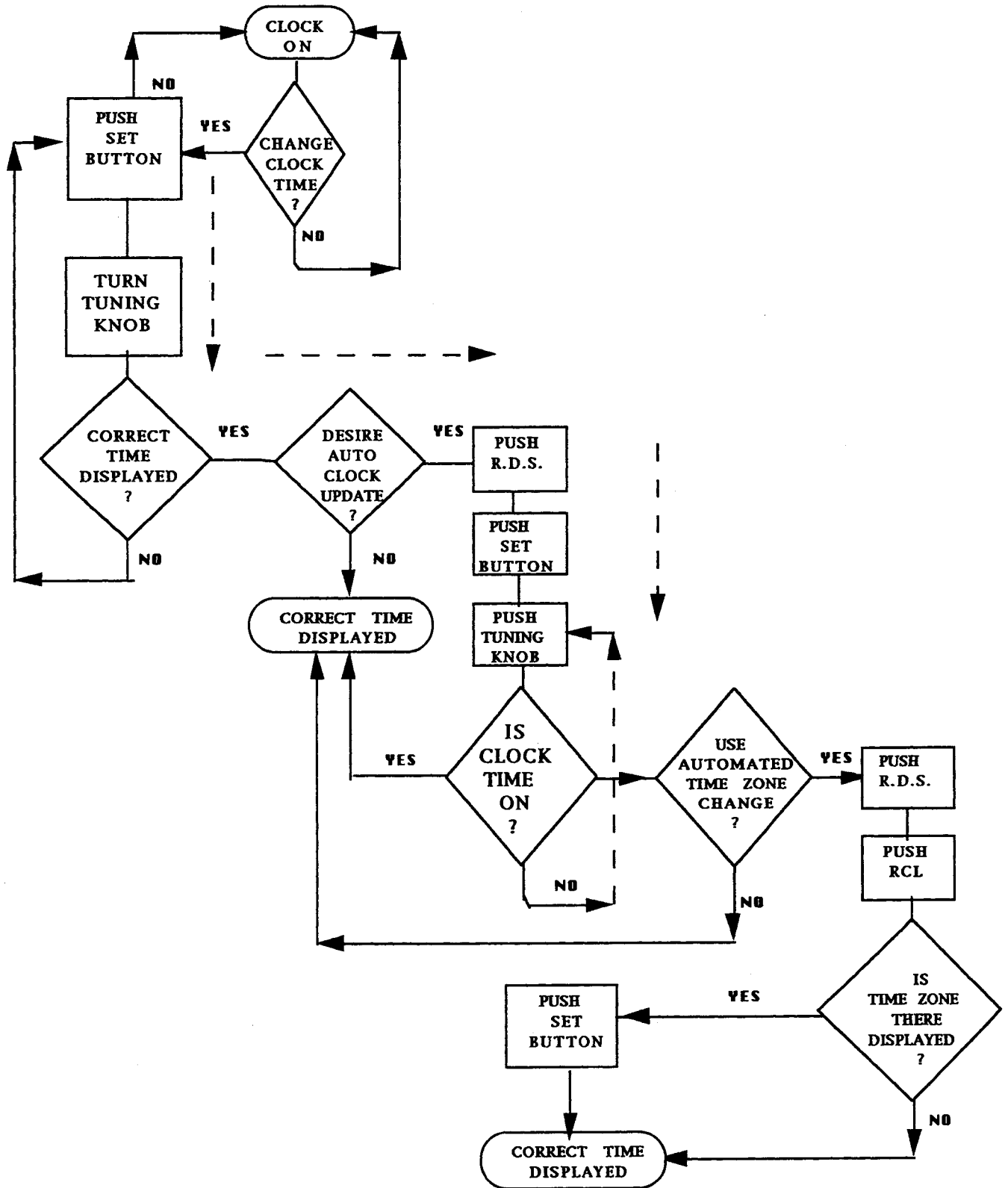

APPENDIX C : Redesigns of Delco receiver.

Advantages to Design A:

1) Switching the equalizer and the message display screen allows the screen to be closer to the driver and centers it between the driver and the passenger.

2) Replace the power button by moving it to the volume knob, the driver can turn the radio on by turning volume knob up and turn it off by moving volume completely down until it clicks off. This allows us to move T.A. on/off toggle switch to the power button's position.

3) R.D.S. is constant and we will not need the secondary functions provided by the R.D.S. button, therefore, we replace the R.D.S. button with the Set button and move the A.F. on/off toggle switch to the Set button's place.

4) This design clarifies the functions provided by the tuning knob: When in normal position it selects between stations (as a normal radio would). When pushed in it clicks into place and tunes between formats. Driver knows by touch how to tune both stations and formats. (A.F. has been moved to R.D.S. button position per #3).

5) We believe listeners would like a choice of preset formats rather than only Rock, Country, Top 40, Urban, & Light, with only one pre programmable favorite button. We would replace button 1-5's preset formats and allow the driver to program a favorite format on each one.

We have eliminated the R.D.S. secondary function button, therefore, the driver needs only choose a format with the tuning knob, hit the set button, and choose button 1-5, he then could preset his five favorite stations of the new format selected. Again the tuning knob when pushed in would allow the selection of formats by pushing preset buttons 1 through 5, or scanning by turning the tuning knob, pushing select up/down or by pushing the scan button. In the same way stations could be selected with the tuning knob out in the same fashion.

6) The scan button has had the favorite format selection removed, allowing us to use it as a scan while in format or station mode.

7) To increase the driver's ability to operate functions while driving and minimizing time looking away from the driving field, a raised bump has been added to the #3 button to allow finger touch sensitivity to add knowledge of buttons #1 and #2 to the left of the bump and buttons #4 and #5 to the right.

8) Addition of a separate rewind and fast forward button to the tape player eliminates confusion of what button does what in which mode. Having all tape controls next to the tape player simplifies usage.

Advantages Continued.

9) Eliminating stop/play button (ST/PL) allows the tape player to operate when a tape is placed in the player and the eject button will stop the tape. This allows us to move the tape player more towards the center.

10) Add an T.A. annunciator light that would flash to alert the driver of a current broadcast of traffic information. Allows the driver to know that a message is playing even when T.A. is off or when listening to another station that is not broadcasting traffic information. Could be a default to the Minn DOT signal, much like the billboards that flash on the highways to tell you to tune into 88.5 F.M. for traffic information.

Disadvantages to Design A:

1) This design adds more buttons which could be and were assigned as dual function buttons before.

2) This design necessitates that the driver pre-program several buttons before driving. Hopefully, users will not try to program the favorite formats and favorite stations while driving.

3) By eliminating ST/PL function the user has to eject the tape or turn the system off to stop a tape, the previous design allowed the tape to be in place but toggled on/off. Presumably when tape is in "ST" mode the radio will operate normally.

4) T.A. annunciator light might annoy user.

DESIGN A

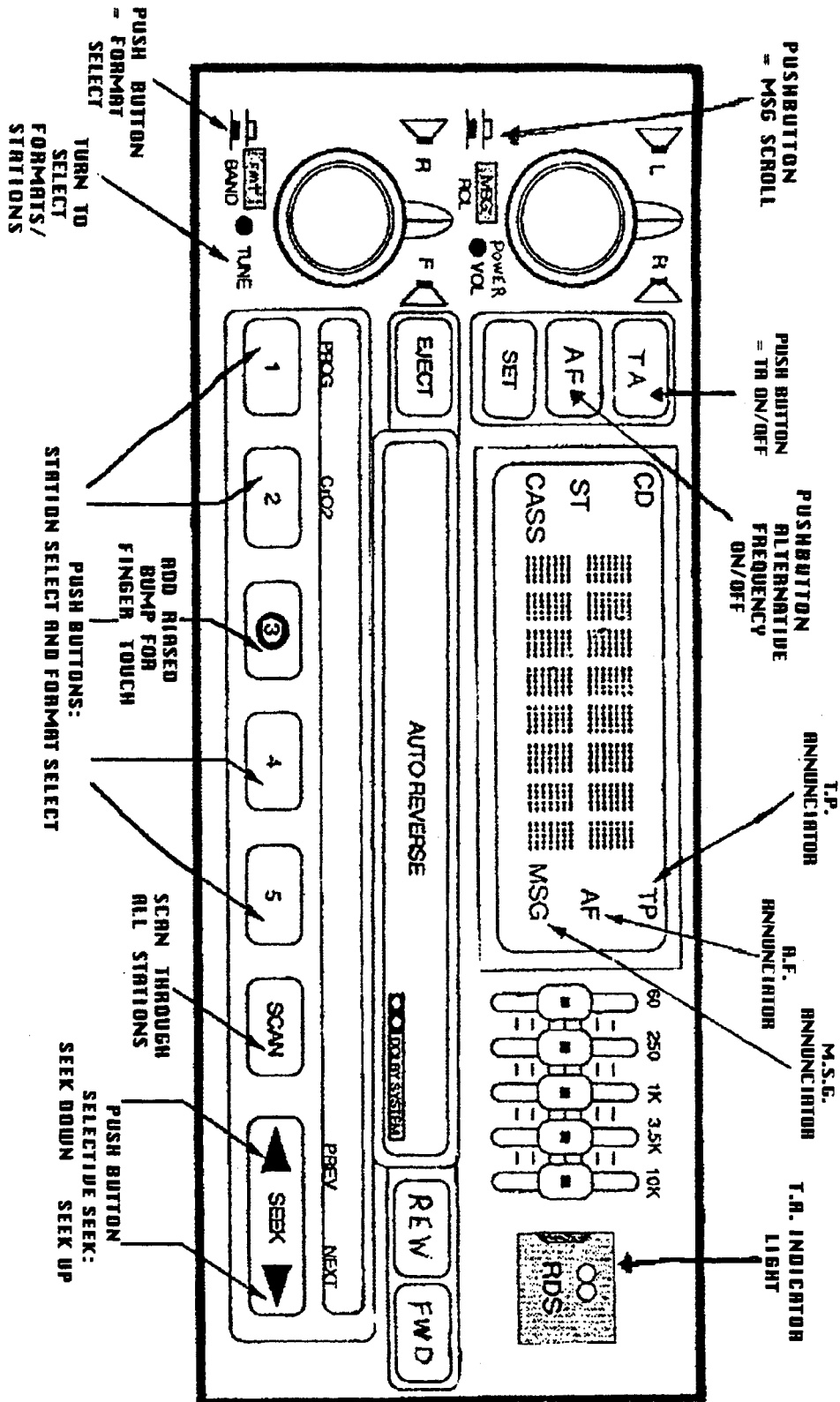

Advantages to Design B:

- 1) Same advantages as Design A.
- 2) Moving the Tuning knob to the far right corner allows us to move the T.A, A.F. and Set button array to the bottom left corner. This allows user to have the buttons that he will use the most closest to him. The Set button will be next to buttons 1-5 which are the buttons he will program and set with the Set button. We also add extra room between the volume and tuning knobs which allows ease of operation by touch.
- 3) With the tuning knob on right we can further move display to center and move tape player and control buttons to center.
- 4) We now have room to operate the volume and tuning knob without disturbing the other.

Disadvantages to Design B:

- 1) Driver has to reach across display to move tuning knob. It becomes hard to tune in stations and formats because user's arm crosses over display.

Advantages to Design C.

The following design incorporates head up display, usage of control buttons on the steering column and a decrease in controls on the radio face plate.

- 1.) Usage of head-up display reduces time spent glancing down at radio. It also allows an increase amount of text characters to be displayed eliminating abbreviations. Finally, it allows drivers to continue to look ahead at the road.
- 2.) Controls on the steering column reduce reaching for controls on the radio.
- 3.) Radio controls on the radio should control radio functions. Moving RDS functions to the steering column allows a sense of special purpose to the RDS functions and could increase their usage.
- 4.) Usage of auditory functions (speech synthesis or tones) increases hands-off operation.

Disadvantages to Design C.

- 1.) Usage of head-up displays does not guarantee safer vehicle operation, and may pose problems of its own.
- 2.) Tradeoff analysis should be done to confirm whether control placements on the steering column increase usage. Again there is no guarantee that these recommendations will serve their intended purpose.

- Heads - up display:**
 Without lowering eyes from driving field,
 1.) Traffic information or messages can be viewed.
 2.) T.A., MSG, A.F., and T.P., annunciators can be seen.

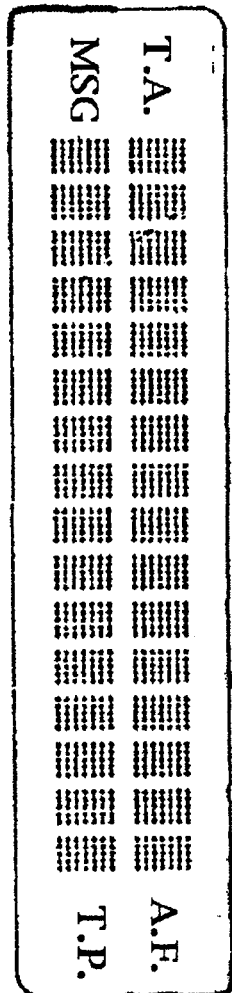

- Steering wheel column:**
 Controls attached to steering wheel or left hand column,
 1.) Traffic announcement & Alternative frequency toggle switch on/off.
 2.) Message scrolling switch.
 3.) Volume and Tuning up/down two position switch.

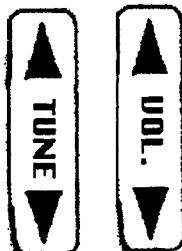

Control plate:
 Handles tape, format, & radio functions

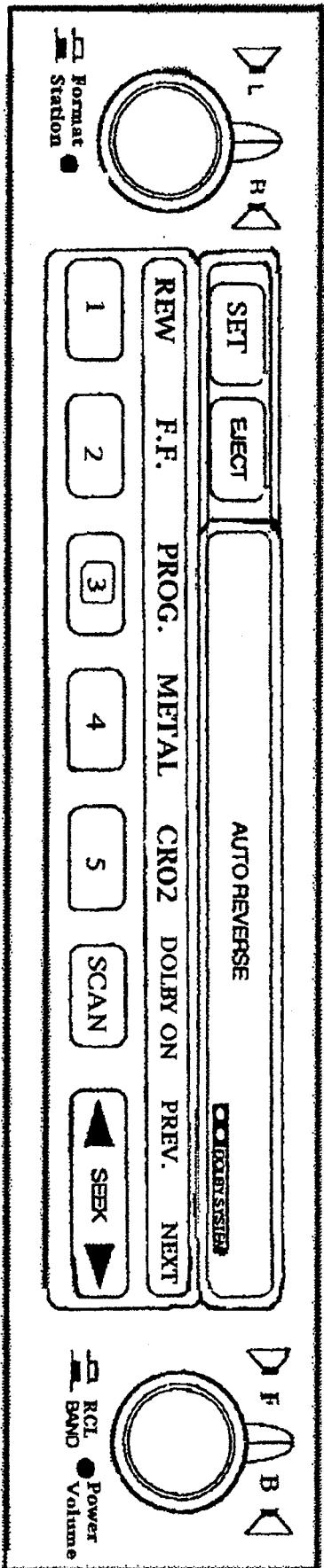

- Auditory Functions:**
 1.) Interrupt tape or radio when T.A. is noticed.
 2.) Restart tape player or return to radio.

APPENDIX D : Static Test Instructions

Please locate the following buttons
on the diagram that follows.

Mark your choices by writing the number of your choice
on top of the blank buttons on the next page.

For example, If you are asked to identify the Volume Knob or
the "Top 40" Format Button you would write the number one
and the number two on the diagram,
like this:

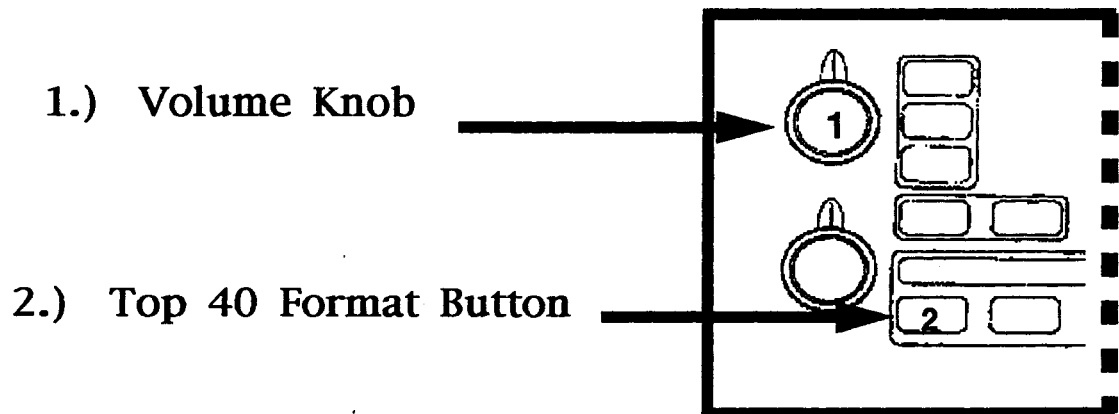

Write the following numbers on the corresponding
part of the diagram

- | | |
|---------------------------|------------------------------------|
| 1.) T.A. Button | 6.) Tape Eject Button |
| 2.) "Light" Format Button | 7.) RCL Button |
| 3.) RDS Button | 8.) Set Button |
| 4.) T.P. Annunciator | 9.) Cassette Program Change Button |
| 5.) Scan Button | 10.) Tuning Knob |

Key for Blank Diagram Test

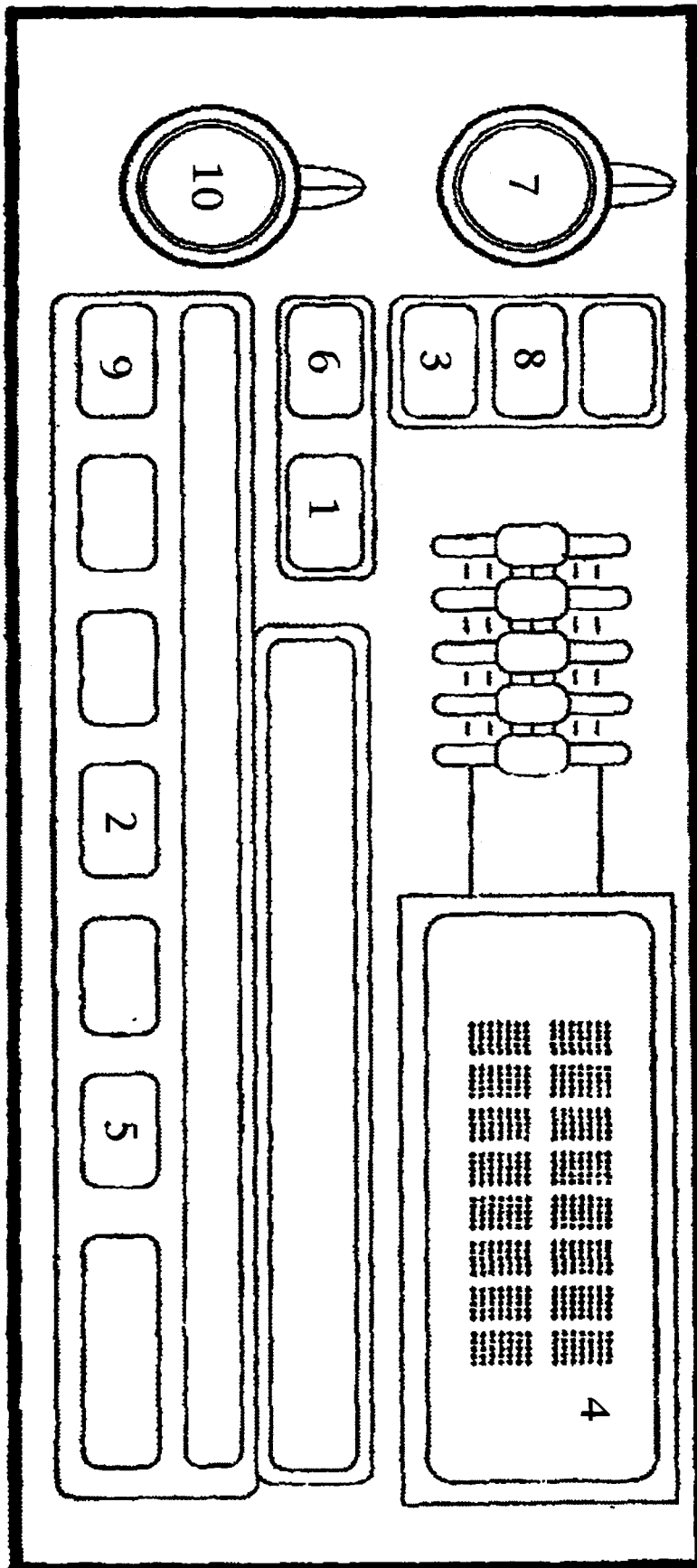

Learning Test / Knowledge Test

1.) You are listening to a National Public Radio program while traveling a long distance. You would like the radio to tune into the station that is broadcasting the best reception of that program automatically. Which button do you press?

- A.) The T.A. Button
- B.) The RDS Button
- C.) The A.F. Button
- D.) The Volume Knob

2.) How do you know that a traffic message is being broadcast? _____

3.) What Button do you press to scroll through the messages?

- A.) Tuning Knob
- B.) Volume Knob
- C.) ST-PL Button
- D.) Seek Button

4.) How would you turn off the traffic announcement function when listening to tapes?

5.) What Button do you press to listen to your "Favorite" Format?

- A.) #1
- B.) #4
- C.) # 5
- D.) Scan Button

6.) Please circle the correct sequence for finding a station with the Rock Format function of the Radio:

- A.) RDS Button, Set Button, Button #2 (Rock Format) , Scan Button
- B.) Set Button, Button #2, Seek Button, Rds Button
- C.) RDS Button, Button #2, Seek Button
- D.) RDS Button, Tuning Button, Button #2, Scan Button

7.) True / False The Scan Button can be used to scan stations while in RDS Mode?

8.) What does "T.P." mean when it is visible on the view screen? _____

9.) Which button do you press to review the last message or broadcast station information on the viewing screen?

- A.) The Volume Knob
- B.) The ST-PL Button
- C.) The Set Button
- D.) The RDS Button

10.) True / False You would use the Tuning Knob to search through different formats.

APPENDIX E : Instructions for participants.

The participants were given the following instruction packet:

Welcome to the Human Factors Research Laboratory. The lab's main area of research is to improve the safety of driving on our roadways. One of the serious causes of accidents is congestion with its fast stops and cars being packed closely together. Congestion adds to other causes of accidents such as: The reduced vision and reflexes of some older drivers, the diminished responsiveness of drivers under the influence of alcohol or drugs, or the general lack of attentiveness produced by the slow movement of congested traffic.

This study, in which you have kindly volunteered to take part, is related to efforts to reduce congestion. We are looking at several radio devices that give drivers current traffic information while they drive. The way that this is done is that your car radio will have a television screen on it that will show you sentences or maps with traffic information on it. The Minnesota Department of Transportation wants to use these so that drivers can help them manage traffic, even in the event of construction delays, bad weather or incidents such as accidents. As a driver you would receive information that an accident has occurred ahead of you and because you have this information from your radio, you will avoid the area and take another route. You are about to help us learn how safe these systems are. The danger with these radios is that you have to look down at them and push buttons to read the messages. When you look at the radio, you are not paying attention to the road ahead. Even if you only glance down quickly at the radio, you can still have a measurable change in your driving. We have asked you to try these radios in a simulator because this is a safe way to test these systems without using them on the highways. We can find out if it is safe to use them in a car before they are used on the roads.

You are about to receive instructions on the radio and the simulator. You will be given as much time as you like to get familiar with the radio and the simulator before we collect any data. You will practice in the simulator until you feel comfortable driving in it. There is no hurry and at any time during the practice or after a trial we can stop and rest. Before we start, please take your time to make sure you are comfortable. However, if you do not feel that you are enjoying the study you may quit at any point. You may ask to stop the study at any time if you feel uncomfortable or do not wish to participate.

You will be asked to do two actual trials in the simulator after you have finished practicing. These trials consist of driving the car at 55 M.P.H. down a straight road toward the Twin Cities, you will reach an intersection with a stop sign where you will make a LEFT turn across traffic, you will continue down a short straight road to another intersection without a stop sign, there you will make another LEFT turn, after which you will drive on another long straight

road. While you are on this final stretch of road we will ask you to catch up to traffic and pass one of the cars on the road. On the first road cars will approach you on the other lane just like a two way street. When you turn onto the final road cars will be traveling with you just like a highway. During these trials you will receive messages about traffic conditions at three different times each trial. We will ask you to read the messages out loud so that we know that you have read them.

After you have completed the two trials, we will ask you to complete a general information questionnaire which we will ask all our participants in the experiment to complete. On this questionnaire we ask how you felt about the radio and what your usual driving habits are. Your responses to the questionnaire and your driving results will be kept confidential. If you would like, the Laboratory can send you a copy of the final report or information on your individual results. At the end of this paper we will ask you to sign a consent form to participate after you have received all instructions. Thank you again for volunteering and if you are ready to go ahead, tell the Laboratory person that you are finished and ready to learn about the radio.

Delco R.D.S. Radio

This is what the Delco radio will look like in the simulator car.

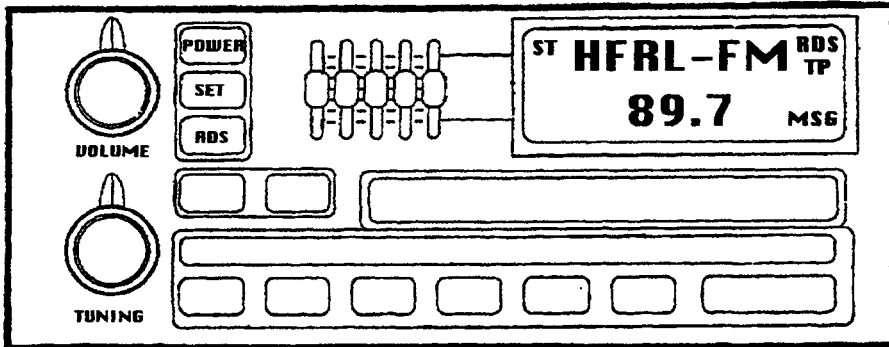

The only buttons that you will need to use are the **RDS Button** and the **Volume Knob**.

When a message is being broadcast your tape will stop.

When your music tape stops it means a new message is being broadcast.

When you feel comfortable, push the **RDS Button** and then press the **Volume Knob**. You will see the text screen change to two lines of text., by pressing the **Volume Knob** again two more lines will appear. By pressing it two more times you will see the four remaining lines of text. You will be asked to read all four screens of text.

The messages will look like this:



The first screen will look like this.

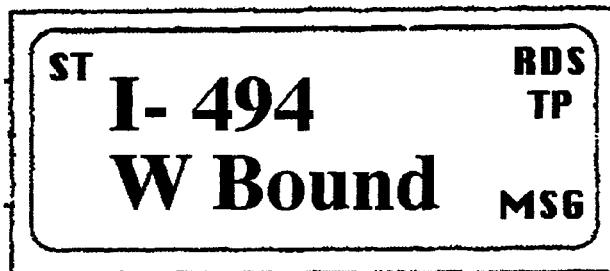

After pushing the Volume knob once, This is what the second screen looks like.

Each line of text is at the most, eight letters long, so there will be some words that are abbreviated to fit them on the lines. This means that the messages might be hard to read; They might look like this:

**Multicar
Accident**

**At Penn
N Bound**

**Near The
Crostown**

**AvoidThe
Area**

This would be read:

"Multi-car accident at Penn Avenue North Bound. Near the Crosstown Highway, Avoid the Area."

When you see a message while driving we will ask you to repeat it out loud, so that we can tell that you can see and read it.

Here is a quick review:

2.) Scroll By Pressing
The Volume Button
In Four Times

1.) Push the RDS Button
First

3.) Read the Message
as it Scrolls

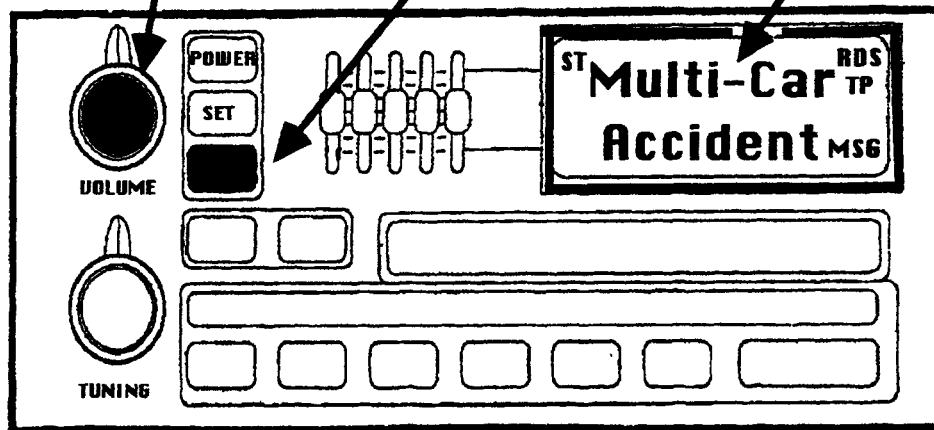

If you need any other help or if you have questions ask the Laboratory personnel now.

APPENDIX F : Post-simulation questionnaire.

Delco Radio Post-Simulation Survey

Participants Name _____.

We are evaluating the prototype Delco Radio Data System (R.D.S.) which you have been using. We need your help. Please answer the following questions. The information you give us is especially important since you are among the few who have used the radio while driving in the simulator.

Usage Patterns:

(Please circle one answer after each question.)

- Do you have a radio in your car now? Yes No
- What Type?
 - A.M. Radio A.M./F.M. Radio only Radio/Cassette player
- How often do you listen to your car radio? Always Occasionally Never
- How often do you listen to tapes? Always Occasionally Never
- Do you listen to the radio for traffic announcements? Yes No

When you normally drive your car every day , what per cent of the time is the radio ON? (fill in percentage 10%, 25%, 100%... for example)

_____ %

What per cent of your driving is in rush hour traffic? (10%, 25%, etc..)

_____ %

Learning to Use the R.D.S. Radio:

(Please circle one answer after each question.)

Were you able to understand the functions of the R.D.S. radio from the instructions that were given to you? Yes No

How hard to understand were the instructions for using the radio? (circle one).

Hard Difficult Tough Normal Easy

Did you need to return to the instructions after first reading them:

Seldom Sometimes Often

Did you understand the instructions as presented to you? Yes No

Were you able to understand instructions during the simulation? Yes No

Procedures in Using the R.D.S. Radio:

(Please circle one answer after each question.)

How easy was the radio to operate?

Easy Normal Tough Difficult Very Hard

Was it easy to push the small buttons on the Radio? Yes No

Did you feel that you were able to keep your eyes on the road the same amount of time as in when you are normally driving your own car? Yes No

If not did the radio system distract you from watching the road? Yes No

Could you read the messages displayed? Yes No

Why not? (please fill in any comments).

Were you able to reach everything on the radio easily? Yes No

Did you have enough time to read the messages after you pressed the R.D.S. button on the Radio? Yes No

How often were you so busy driving that you had to wait before operating the radio?

Seldom Sometimes Often

Did you ever feel that your attention was being spread too thinly?

Seldom Sometimes Often

How often did you feel that the Radio was distracting you from driving?:

Seldom Sometimes Often

How hard was it to tell that messages were being broadcast?

Hard Difficult Tough Normal Easy

Did you find it convenient to scroll through the messages? Yes No

Were you able to read the messages while sitting normally in your car seat?
(in other words, answer No if you had to lean over to read the messages)
Yes No

Clarity and Visibility:

(Please circle one answer after each question.)

How often were the words on the buttons too difficult to read because of the dim light?

Seldom Sometimes Often

Was the meaning of the displayed messages understandable:

Seldom Sometimes Often

What messages or words in a message did you have trouble understanding and why?

Overall Evaluation:

(Please fill in comments or circle answers after each question.)

What was the last message that you read on the R.D.S. Radio viewing screen?

Would you buy an R.D.S. Radio like the one you have been using if the price were slightly more than a conventional radio? (Circle one). Yes No

Would you buy this R.D.S. Radio if the only thing extra that it did was to provide additional traffic information on a screen? Yes No

Would you pay more attention to a screen like this that you have to read, or to a traffic announcement on a radio station?

Radio Screen Radio Station announcement

Which would you believe is giving the most accurate advice on traffic conditions or congestion?

Radio Screen Radio Station announcement

Do believe that this radio might jeopardize safety while driving?

Seldom

Sometimes

Often

Did the driving simulator make you feel as though you were actually driving a car?

Yes

No

Why or why not? (please write in comments)

Comments:

Please make any comments about the Delco R.D.S. radio that might help us in evaluating this device. You may also comment on anything you would like to say about the radio, the simulator, or our facility. These would be greatly appreciated and used in our overall improvement of this test. Thank you for your help.

APPENDIX G : Trilogy Operators and Information Officers questionnaires

Trilogy Operator Questionnaire

Control Room:

(1) Where do you think the crusader operator should be placed in the control room? (present place, between the north and south stations, other?)
explain...

Software Operations:

(2) Do you think using the software is simple enough for anyone to use?
yes no
explain...

(3) What are the difficulties with using the software?

(4) What do you find easy to use on the software?

Messages:

(5) In a peak period shift, what are the most messages you have sent?

_____.
*least messages sent...

_____.

(6) At any one moment what are the most messages you have sent?

(7) Which messages do you send most often?

- * What constitutes congestion...
- * What constitutes an accident...
- * What constitutes an incident...

(8) How is a gawker's' delay handled?

(9) What are the uncertainties you have when sending a message?

(duration estimates, location, type of incident)

- *Who do you ask for help?
- *How many times during a average peak shift do you ask for help?

Sending Messages:

(10) How often do you ask what location to send?

never seldom usually most of the time always

(11) How often do you ask what type of incident to send?

never seldom usually most of the time always

(12) How often do you ask what duration of time an incident will last to send?

never seldom usually most of the time always

(13) How often do you ask what direction the incident is in?

never seldom usually most of the time always

(14) What are your opinions on the message list? (too long, too short, not enough valid messages, grouping or location of the message lists (location lists).)

(15) How often do you find an exact message to match the incident that has occurred?(fill in percent)_____.%

(16) How often do you find an exact location to match the incident that has occurred?(fill in percent)_____.%

(17) How difficult is it to cancel a message?

not at all somewhat moderately fairly very

(18) How difficult is it to change a message?

not at all somewhat moderately fairly very

(19) Any suggestions on how to make it easier?

explain...

(20) What is your overall rating of the crusader software?

unusable weak fair good excellent

(21) Please tell us your overall opinion of the crusader software. (likes, dislikes, difficulties, things that are easy, etc..)

(22) What would you like to see done differently?

*how you get the information on accidents and incidents?

*your location in the control room?

*the order of the phrases on the message and location lists?

*other...

(23) If you were designing this software, what would you do differently?

(24) Any other suggestions...

Information Officer Questionnaire

(1) How often do the crusader operators ask you for information?

(fill in percent)

_____.

%

***what kind of information do they ask?**

explain...

(2) Do these questions hamper your ability to do your job effectively?

yes

no

explain...

(3) Have you ever received useful information from the crusader operators?

yes

no

explain...

